



HP DesignJets 500 and 800 Series

Large-Format Printers



Service Manual

For HP Internal Use Only

©Copyright Hewlett-Packard Company 2000

This document contains proprietary information that is protected by copyright. All rights are reserved. No part of this document may be photocopied, reproduced, or translated to another language without the prior written consent of Hewlett-Packard Company.

First Edition, August 2000

Warranty

The information contained in this document is subject to change without notice.

Hewlett-Packard makes no warranty of any kind with regard to this material, including, but not limited to, the implied warranties of merchantability and fitness for a particular purpose.

Hewlett-Packard shall not be liable for errors contained herein or for incidental or consequential damages in connection with the furnishing, performance, or use of this material.

WARNING

The procedures described in this manual are to be performed by HP-qualified service personnel only.

Electrical Shock Hazard

Serious shock hazard leading to death or injury may result if you do not take the following precautions:

- Ensure that the ac power outlet (mains) has a protective earth (ground) terminal.
- Disconnect the Printer from the power source prior to performing any maintenance.
- Prevent water or any other liquids from running onto electrical components or circuits, or through openings in the enclosure.

Electrostatic Discharge

Refer to the beginning of Chapter 8 of this manual, for precautions you should take to prevent damage to the Printer circuits from electrostatic discharge.

Safety Symbols

General definitions of safety symbols are given immediately after the table of contents.

WARNING

The Warning symbol calls attention to a procedure, practice, or the like, which, if not correctly performed or adhered to, could result in personal injury. Do not proceed beyond a Warning symbol until the indicated conditions are fully understood and met.

CAUTION

The Caution symbol calls attention to an operating procedure, practice, or the like, which, if not correctly performed or adhered to, could result in damage to or destruction of part or all of the product. Do not proceed beyond a Caution symbol until the indicated conditions are fully understood and met.

HP DesignJets 500 and 800 Series

Large-Format Printers



Service Manual

Using this Manual

Purpose

This Service Manual contains information necessary to test, calibrate and service:

- HP DesignJet 500 Printer - 24" Model (P/N C7769B)
- HP DesignJet 500 Printer - 42" Model (P/N C7770B)
- HP DesignJet 500PS Printer - 24" Model (P/N C7769C)
- HP DesignJet 500PS Printer - 42" Model (P/N C7770C)
- HP DesignJet 800 Printer - 24" Model (P/N C7779B)
- HP DesignJet 800 Printer - 42" Model (P/N C7780B)
- HP DesignJet 800PS Printer - 24" Model (P/N C7779C)
- HP DesignJet 800PS Printer - 42" Model (P/N C7780C)

For information about using these printers, refer to the corresponding User and Quick Reference Guides.

Readership

The procedures described in this Service Manual are to be performed by HP Certified Service Personnel only.

Part Numbers

Part Numbers for Printer options, accessories and service parts are located in Chapter 7.

Conventions

A small arrow \Rightarrow is used to indicate other parts of the Service Manual where you can find information related to the topic you are consulting.

Table of Contents

Troubleshooting 1-1

- Introduction 1-2
- Troubleshooting System Error Codes 1-2
- Solving Print Quality Problems 1-3
 - Cover Sensors are not Working 1-3
 - The Line Sensor has Problems Detecting Media 1-3
 - Troubleshooting Paper-Axis Shutdowns 1-4
 - Problems with the Vacuum Fan 1-5
 - Vacuum suction much lower at high altitudes 1-5
 - HP-GL/2 color differences in different HP DesignJet Printers 1-6
 - Banding at variable extreme environmental conditions 1-6
 - The Priming Procedure Fails 1-7
- Using the Power Switch LED to Troubleshoot 1-10
- Using the Boot-Up Sequence to Troubleshoot 1-12
- Using the Formatter/Accessory Card LEDs to Troubleshoot 1-14

System Error Codes 2-1

- Introduction 2-2
- Continuable and Non-Continuable Error Codes 2-2
- System Error Codes - Explanation 2-2
- Error Log Utility 2-5
- Accessing the Error Log Utility 2-5

Ink Supplies Troubleshooting 3-1

- What are the Ink Supplies? 3-2
- Ink Cartridges 3-2
- Printheads 3-3
- Identifying the Components 3-3
- General Information About the Ink Supplies 3-4
- Some General Precautions When Handling the Ink Supplies 3-5
- When Should You Replace the Ink Cartridges? 3-6
- When Should You Replace the Printheads? 3-7
- Obtaining Ink Cartridge Information 3-9

- Obtaining Printhead Information 3-10
- Ink Cartridge Status Messages 3-12
- Ink Cartridge Status While Replacing 3-12
- Printhead Status Messages 3-13
- Printhead History Utility 3-14
- Accessing the Printhead History Utility 3-14
- Is the Printer Causing Repetitive Printhead Problems? 3-16
- Is the User Replacing the Printheads too Early? 3-18
- Troubleshooting Repetitive Ink Cartridge Messages 3-20
- Troubleshooting Repetitive Printhead Error Messages 3-21
- Printhead Error Codes 3-22
- Summary of Solving Ink Supplies Problems 3-23

Service Tests and Utilities 4-1

- Introduction 4-2
- Phone Support 4-2
- Diagnostics - Self Test 4-2
- Service Tests (Diagnostics) 4-3
- Entering the Service Tests Menu 4-4
- Ink Supply Station 4-6
- Carriage Movement 4-8
- Paper Advance Test 4-10
- Service Utilities 4-13
- Entering the Service Utilities Menu 4-14
- EEROM Setup 4-16
- Turn Drive Roller 4-21
- Unlock Carriage 4-22
- Prime Tubes 4-23
- Change Cutter 4-24
- Change Ink Tubes 4-25
- Printer Information 4-26

Service Calibrations 5-1

- Entering the Service Calibrations Menu 5-3
- Printhead Alignment (includes PPS Calibration) 5-5
- Color Calibration 5-7
- Advance Calibration 5-9
- Factory Advance Calibration 5-11

Print Quality 6-1

- Print Quality 6-2
- Print Quality Troubleshooting Checklist 6-2
- How to Use the Troubleshooting Procedure 6-4
- What is the Troubleshooting Procedure? 6-4
- Considerations for Using the Troubleshooting Procedure. 6-4
- Performing the Troubleshooting Procedure 6-4
- Troubleshooting Procedure Flowchart 6-7
- No Printing Defects Found Using the Troubleshooting Procedure 6-8
- Solving Color Accuracy problems 6-9
- Color Consistency problems 6-9
- Long Term Color Bleeding (Glossy Papers) 6-9
- Media 6-10
- There are Smears or Scratching on the Printed Media 6-10

Parts and Diagrams 7-1

- Printer Support 7-2
- Right Hand Cover 7-4
- Left Hand Cover 7-6
- Top Cover and Deflectors 7-8
- Rollfeed Module 7-10
- Back Platen Assembly 7-12
- Electronics Module 7-14
- Power Supply 7-16
- Cutter Assemblies 7-18
- Ink Delivery System 7-20
- Service Station and Spittoon 7-22
- Service Station Holder 7-24
- Pinch-Wheel Assemblies 7-26
- Scan-Axis Motor 7-28
- Drive Roller Encoder Sensor 7-30
- Print Platen Assembly 7-32
- Carriage Assembly 7-34
- Vacuum Fan 7-36
- Interconnect Cable 7-38
- Paper-Axis Motor 7-40
- Drive Roller 7-42
- Miscellaneous Items 7-44

Removal and Installation 8-1

Introduction	8-2
Safety Precautions	8-2
Electrostatic Discharge (ESD) Precautions	8-3
Required Tools	8-3
Screw Types	8-4
Left Hand Cover	8-5
Right Hand Cover	8-7
Front Panel	8-9
Window and Top Cover	8-10
Media Deflectors	8-11
Left End Roll-Feed	8-13
Right End Roll-Feed	8-15
Back Platen	8-17
Media Sensor	8-19
Formatter	8-20
LAN Card	8-21
Spittoon	8-23
Electronics Module	8-24
Power Supply	8-27
Scan-Axis Motor Assembly	8-29
Cutter Assembly	8-32
Left Encoder Holder	8-33
Cutter Bushing	8-35
Cutter Guide Bracket	8-36
Drive Roller Encoder Sensor	8-38
Trailing Cable	8-40
Ink Supply Station	8-48
Interconnect PCA	8-50
Service Station and Aerosol Fan	8-52
Cutter Guide	8-55
Print Platen	8-56
Service Station Holder	8-57
Interconnect Cable	8-59
Ink Supply Tubes	8-60
Vacuum Fan	8-64
Pinch-Arm	8-66
Pinch-Arm Mechanism	8-67
Pinch-Arm Lever	8-69

- Pinch-Arm Sensor 8-71
- Fork Idler, Tensioner and Idler Pulley 8-74
- Encoder Strip 8-76
- Carriage Assembly (Including Belt) 8-78
- Paper-Axis Motor 8-84
- Drive Roller 8-86
- Gear Assemblies 8-92

Preventive Maintenance 9-1

- Moisture on the Printer 9-2
- Noisy Carriage Bushing 9-2
- Belt Swelling 9-2
- Cleaning the Printer 9-2
- General Cleaning 9-2
- Cleaning the Drive Roller/Print Platen 9-3
- Scheduled Maintenance 9-3
- Level of Printer Usage 9-3
- Scan-Axis Maintenance 9-4

Functional Overview 10-1

- Introduction 10-2
- SKU Overview 10-2
- Electrical System 10-3
- Introduction 10-3
- Hardware Description 10-3
 - Power Supply Unit (PSU) 10-5
- Front Panel 10-6
- Ink Delivery System (IDS) 10-7
- Ink Supply Station (ISS) 10-7
- Tubes Assembly 10-9
- Service Station 10-10

Glossary

Index

Troubleshooting

1

Introduction	1-2
Troubleshooting System Error Codes	1-2
Performing a Service Test on a Failed Assembly	1-2
Performing the Necessary Service Calibrations	1-2
Solving Print Quality Problems	1-3
The Printer does not Power ON	1-3
Cover Sensors are not Working	1-3
The Line Sensor has Problems Detecting Media	1-3
Troubleshooting Paper-Axis Shutdowns	1-4
Problems with the Vacuum Fan	1-5
Vacuum suction much lower at high altitudes	1-5
HP-GL/2 color differences in different HP DesignJet Printers	1-6
Banding at variable extreme environmental conditions	1-6
The Priming Procedure Fails	1-7
Using the Power Switch LED to Troubleshoot	1-10
Using the Boot-Up Sequence to Troubleshoot	1-12

Guide to Troubleshooting the Printer

Introduction

This chapter will guide you through the relevant steps to take when troubleshooting the printer.

Troubleshooting System Error Codes

Chapter 2 - *System Error Codes* contains a list of system error codes and their respective descriptions and recommended corrective actions. Only try one recommended action at a time and check if the error code has disappeared.

Performing a Service Test on a Failed Assembly

If possible, always perform a Service Test on the component/assembly that you are about to replace, just to make sure that is the component/assembly that has failed.

NOTE

If the test on that component/assembly passes, you should NOT replace it.

For information on the Service Tests and how to use them see Chapter 4 - *Service Tests and Utilities*.

Performing the Necessary Service Calibrations

Is the printer calibrated correctly after replacing a component?

NOTE

Remember that certain Calibrations are required even if an Assembly has been disassembled to gain access to another Assembly or Component.

For information on the Service Calibrations and how to use them see Chapter 5 - *Service Calibrations*.

Solving Print Quality Problems

The Printer contains an internal **Troubleshooting** procedure which helps you to diagnose and resolve the possible source of any Image Quality or Line Quality defects. If Print Quality is poor **before** the minimum life expectancy of the Printhead has been reached, the **Troubleshooting** procedure should be performed which will determine whether the Printhead needs replacing or not after performing various levels of recovery actions.

For information on solving Print Quality problems see Chapter 6 - *Print Quality*.

The Printer does not Power ON

- 1** Check that the power cord is connected correctly to the Printer and to the Power Socket.
- 2** Check that the Front-Panel Cable is correctly connected to the Interconnect PCA. Also make sure that the Front-Panel cable is not damaged.
- 3** Check that the Interconnect Cable is properly connected at the both ends of the Printer.

Cover Sensors are not Working

- 1** Check if the faulty sensor is installed correctly.
- 2** Check if the cable for the faulty sensor is connected correctly.
- 3** Replace the faulty Sensor (or the assembly that contains the Sensor).

The Line Sensor has Problems Detecting Media

- 1** Check the type of media that is being used since the Line Sensor may have problems detecting transparent media or some types of Non-HP media. Try loading white HP media in to the Printer and check if the Line Sensor detects it.
- 2** Excessive ink deposits on the Print Platen surface can fool the sensor by reflecting the light. Clean the Print Platen.
- 3** The Line Sensor is damaged or faulty. Replace the Carriage Assembly ⇒ Page 8-78.

Troubleshooting Paper-Axis Shutdowns

A Paper-Axis shutdown can happen when the Printer detects that the Drive Roller is **not** moving but at the same time power is being supplied to the Paper-Axis Motor (which should be turning the Drive Roller).

The reasons for the Paper-Axis shutdown, and their solutions, are explained as follows:

- 1 The Paper-Axis Motor does not respond to the electrical simulation.
 - It is possible to determine whether the Paper-Axis is faulty by performing the Paper Advance Test (Refer to Page 4-10). The Printer will move the Motor backwards and forwards and measure directly from the Motor Encoder whether the Paper-Axis Motor responded to the force. If the Paper-Axis Motor did not respond, the solution would be to replace the Paper-Axis Motor ⇒ Page 8-84.
- 2 The Transmission Gears, which transmit the movement to the Drive Roller, are not turning. This problem could be caused either by blockage of the gears (caused by an obstacle) or by one of the gears being damaged. To solve the problem, try the following:
 - Remove the Back Platen ⇒ Page 8-67 and check if there are any obstacles blocking the Gears. Remove the obstacles if necessary.
 - Remove the Back Platen ⇒ Page 8-67 and check if the Transmission Gears are damaged. If the Gears are damaged, replace the Gear Assemblies ⇒ Page 8-92.
- 3 The Drive Roller cannot move because of an obstacle or because it is damaged. To solve the problem, try the following:
 - Remove the Back Platen ⇒ Page 8-67 and check if there are any obstacles blocking the Drive Roller. Remove the obstacles if necessary.
 - Remove the Back Platen ⇒ Page 8-67 and check if the Drive Roller is damaged. If the Drive Roller is damaged, replace the Drive Roller ⇒ Page 8-86.
- 4 The Drive Roller Encoder Sensor is faulty
 - It is possible to determine whether the Encoder Sensor is faulty by loading a sheet of paper from the front of the Printer. If the Drive Roller is working, the sheet will be loaded correctly, and the Printer will detect that media has been loaded (using the Media Sensor). Therefore the problem must be the Encoder Sensor and the solution would be to replace the Encoder Sensor ⇒ Page 8-38.

Problems with the Vacuum Fan

If you have problems loading either Roll or Sheet Media, then there could be a problem with the Vacuum Fan. To verify if there really is a problem with the Vacuum Fan, try the following:

- 1 With the Printer ON, open the Window of the Printer and place a sheet of HP High Gloss Photo Paper (must be D-Size), aligned with the blue lines on the Center Platen. If the Vacuum Fan holds the sheet in place, and then loads it correctly, then the Vacuum Fan functions correctly. If the Vacuum Fan does not hold the sheet in place (no suction), then try the following:
 - Check that the holes in the Center Platen are NOT blocked.
 - Check that the Vacuum Fan is installed correctly.
 - Replace the Vacuum Fan ⇒ Page 8-64.
- 2 If the Vacuum Fan held the sheet in place, but couldn't correctly load it, then there could be a problem with the Drive Roller. In this case, replace the Drive Roller ⇒ Page 8-86.

Vacuum suction much lower at high altitudes

Sometimes, at high altitudes, the vacuum force holding down the media will be lower, therefore the media will not be held in place properly causing:

- Ink Smearing on the Media.
- Printhead crashes against the Media.
- Cut Sheet loading problems (high probability).
- Roll Media loading problems (low probability).

The solution to this would be to change the Vacuum force by changing the Altitude setting. This can be done via the front panel ⇒ Set-up Menu / Altitude.

HP-GL/2 color differences in different HP DesignJet Printers

Color differences between one image printed on the HP DesignJet 500/800 Series and the rest of the DesignJet platforms are due to the different chemistry of the 500/800 series inks compared with the rest of the inks for other printers. This color variability among different HP DesignJet Series Printers has always been present. To solve the problem, try the following:

- Perform the color calibration from the driver at the time of printing. However, that calibration is not very accurate but it may help in the most severe cases.
- Some applications have color controls for the user to modify the image in order to obtain the desired colors.
- Printing with PostScript reduces the problem significantly.
- Avoid very long exposures to extreme environmental conditions after printing with glossy media (more than 12 hours at 80% humidity may result in severe changes in color).

Banding at variable extreme environmental conditions

Since the Accuracy Calibration has been done at normal environmental conditions, printing in extreme environmental conditions will cause banding because the advance of the Drive Roller does not correspond to the same conditions that the calibration was done in. To solve the problem, try the following:

- Perform the Accuracy Calibration in the new environmental conditions (Refer to the User's Guide).

The Priming Procedure Fails

When the customer first receives the Printer, it is supplied with a set of **four** Start-up Printheads pre-installed in the Printhead Carriage. These Start-up Printheads are used for the priming of the tubes in the Ink Delivery System.

When the Printer is powered ON for the first time, the Printer will automatically perform the priming process. Without the priming process, the customer will **NOT** be able to use the Printer.

The initial startup assumes that the Start-up Printheads are installed, but the Printer cannot detect them because the Printer can only detect normal Printheads. If normal Printheads are installed during the initial startup, the Printer will request the User to remove them and check if they really have been removed. It will then request the User to install the Start-up Printheads.

Also the Printer will request the User to install the Ink Cartridges if they have not been installed already. If the Ink Cartridges contain less than 20cc of ink (the Ink Cartridges are encoded with the quantity of ink remaining) they will be rejected. Normally with a new Printer this should not be a problem since the Printer comes with Ink Cartridges that are full, but there maybe cases when the Ink Supply Tubes need to be replaced, in which case half empty Ink Cartridges may be used.

Once the Printer assumes that the Start-up Printheads and Ink Cartridges with enough ink are installed, the priming process will begin.

If the priming process is completed successfully, the Printer will directly proceed to the Printhead replacement procedure in order to replace the used Start-up Printheads with normal Printheads.

Once the priming process has started, it can fail due to 2 different problems:

- The Ink Supply Tubes were not completely empty - This is the most common cause especially if the Printer has been powered ON and OFF several times with the Ink Cartridges installed since the initialization process performs at least one pumping cycle.
- The Printer detects that one or more of the tubes cannot be detected as filled with ink - The most likely cause for this problem is Ink Cartridges with a faulty valve.





Even if the priming process fails, the Printer will try to verify whether the priming process has been completed by moving the Carriage to the access position and you will see the following

message on the Front Panel:

**Unable to prepare
ink system.
Open window to check
SETUP printheads**

Open the Window and you will see the following message on the Front Panel:

**1. Lift printhead cover
2. Check if there is ink
inside printhead windows
3. Press ENTER to continue**



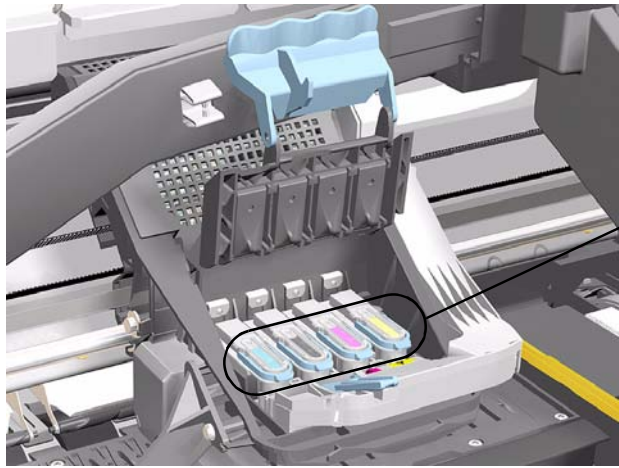

-   Menu
-   Back
-  Enter



Open the Carriage Cover and check if there is ink inside the Start-up Printheads. On the Front Panel you will see the following question and you will need to select the answer depending on whether the Start-up Printheads were filled with ink or not:

**Are all printhead windows
filled with ink?**

**ALL with some ink
NOT all with ink**

-   Menu
-   Back
-  Enter

If there is ink in **all** of the Start-up printheads, the Printer considers that the priming procedure has been completed successfully and will proceed to the Printhead replacement process.

If you select **NOT all with ink** the Printer will react differently depending on the source of the problem:

NOTE

If you need to reseal the Start-up Printheads, make sure you re-insert them in the same color slot in the Carriage.

- The Printer will request you to reseal the Start-up Printheads (or in the case of missing Start-up Printheads you should install them or order new ones) and then retry the priming process (if the priming process fails 3 times because of the same problem, it will display a System Error). In this situation, the problem could be the following:
 - 1 The Start-up Printheads were **not** installed correctly or they are missing (one or all of them).
 - 2 The Start-up Printheads do not work properly and do not allow air to flow (one or all of them).
 - 3 The Ink Supply Station fails to pressurize the Ink Cartridges. To check this, perform the Ink Supply Station test ⇒ Page 4-6.
 - 4 The Ink Supply Tubes are blocked, preventing the ink from flowing correctly.
- If a System Error is displayed, try the following:
 - 1 The Ink Cartridge valve is broken so the Ink Cartridge should be replaced.
 - 2 The Start-up Printhead is not working properly and allows ink to flow outside.
 - 3 The Ink Supply Tube is leaking.

NOTE

The last 2 cases will be more obvious because there will be a lot of ink in the Printer (around 20 cc of ink). Remove the Ink Cartridges and release the Tubes Bracket from the Ink Supply Station and check if there is ink in this area.

For more information on this problem, refer to System Error **93:10** on Page 2-19.

Using the Power Switch LED to Troubleshoot

In certain circumstances the LED located in the power switch (located on the left hand side of the Printer) can help to troubleshoot the Printer. The LED can be OFF, ON or flashing and using different combinations can indicate different problems.

NOTE

You should only use the LED to troubleshoot when the Printer does not Power up completely. The LED may flash in other circumstances which are completely normal and this does not mean that there is a problem with the Printer.



LED is OFF - This indicates that the Power Supply Unit is completely dead. Try the following:

- 1 Check that power cord is connected correctly to the Printer and to the Power Socket. Also make sure that you firmly press the Power Switch to the ON position.
- 2 Replace the Power Supply Unit ⇒ Page 8-27.

LED is ON (all the time) - This indicates that the Main PCA is completely dead. Replace the Electronics Module ⇒ Page 8-24.

LED is Flashing continuously - A problem has been detected with the previous firmware upgrade. Try resending the firmware upgrade file.

LED Flashes twice every few seconds - The Printer cannot detect

the Interconnect Cable. Try the following:

- 1 Check that the Interconnect Cable is connected correctly to the Electronics Module and to the Interconnect PCA.
- 2 If the Interconnect cable is connected correctly and the LED continues to flash twice then replace the Interconnect Cable ⇒ Page 8-59.

LED Flashes 3 times every few seconds - The Printer cannot detect the Front Panel. Try the following:

- 1 Check that the Front Panel is connected correctly to the Interconnect PCA.
- 2 Check that the Interconnect Cable is properly connected at the both ends of the Printer.
- 3 If the Front Panel is connected correctly and the LED continues to flash 3 times then replace the Front Panel ⇒ Page 8-9.
- 4 Replace the Interconnect Cable ⇒ Page 8-59.
- 5 Replace the Electronics Module ⇒ Page 8-24.

LED Flashes 4 times every few seconds - This indicates that the Main PCA has failed. Replace the Electronics Module ⇒ Page 8-24.

LED Flashes 5 times every few seconds - This indicates that the Main PCA has failed. Replace the Electronics Module ⇒ Page 8-24.

Using the Boot-Up Sequence to Troubleshoot

When you Power On the Printer, the Printer performs the Boot-Up sequence which initializes the major components of the Printer. If for some reason the Boot-Up sequence fails because a component has failed to initialize, the following explanations will help you to locate the failing component:



During the first phase of the Boot-up sequence (all the squares turn grey) the Printer is initializing the Operating System. If for some reason this sequence fails, try the following:

- 1 Switch the Printer Off and wait a few minutes. Switch the Printer On again and check if the initialization sequence is successful.
- 2 If the initialization sequence fails again, replace the Electronics Module ⇒ Page 8-24.



During the second phase of the Boot-up sequence (all the squares turn black) the Printer is initializing various components (too numerous to mention). In normal circumstances, if a component fails during this sequence a System Error will appear and you should refer to Chapter 2 - *System Error Codes*. The following information explains what is being initialized as each square turns black:



Initializing various components of the Main PCA.











Initializing various components of the Main PCA.



Initializing a portion of the Firmware.



Initializing various components of the Main PCA.

-  Initializing various components of the Main PCA.
-  Initializing a portion of the Firmware.
-  Initializing the I/O.
-  Initializing the User Interface (Front Panel menus).
-  Initializing a portion of the Firmware.
-  Initializing the Formatter.
-  Initializing the communication between Main PCA and Formatter.
-  End of initialization sequence.

Entering Service Menu at Power Up - Only for Onsite Repair

If the Printer fails to initialize completely because of a System Error and you need to use the Service Menu (Service Tests and Utilities), the Printer can be powered up in Service Mode by pressing the **Up** and **Enter** keys while switching the Printer ON. This will give you access to some of the Service Tests and Utilities without having to complete the System Initialization (if you perform some of the tests, they will need to initialize the relevant part of the System).

Using the Formatter/Accessory Card LEDs to Troubleshoot

In certain circumstances the LEDs located in the Formatter or HP-GL/2 Accessory Card can help to highlight certain failures. There are 3 LEDs, Red, Yellow and Green and using different combinations can indicate different problems.



LED's on the HP-GL/2 Accessory Card

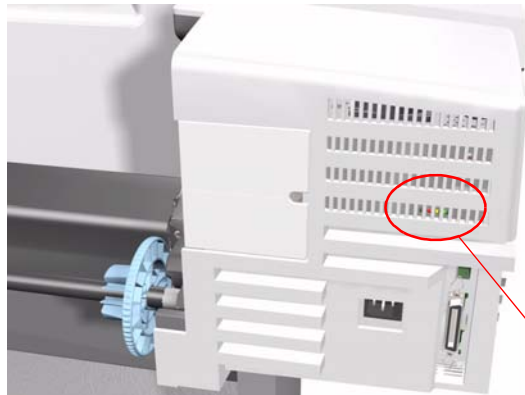

The LED's on the Formatter can be seen without having to remove the Left Hand Cover.



LED's on the Formatter

- The yellow LED (normally flashing) indicates that the Formatter/Accessory Card is alive. If it stops flashing, it means that the Formatter/Accessory Card has failed and should be replaced.
- The green LED indicates that there is power being supplied to the

Formatter/Accessory Card. If the green LED is NOT lit and the LED in the Power Switch is ON, then it could mean that the Formatter/Accessory Card is badly connected or that the Printer is switched OFF. If after reseating the Formatter/Accessory Card, the problem persists, try the following:

- 1** Switch the Printer OFF and remove the Formatter/Accessory Card BUT leaving the LAN Card installed (if available). Switch the Printer ON. If the Printer powers up correctly and the LAN Card works properly, then try **step 2**. If the LAN Card doesn't work, then try **step 3**.
- 2** Switch the Printer OFF and remove the LAN Card from the current slot and install the Formatter/Accessory Card in the same slot (that was previously used by the LAN Card). Switch the Printer ON and check if the green LED in the Formatter/Accessory Card is lit. If the green LED is NOT lit, it means that the Formatter/Accessory Card is faulty and should be replaced.

If the green LED is lit, then switch the Printer OFF and install the LAN Card in the vacant slot. Switch ON the Printer and check if the LAN Card works properly. If the LAN Card does NOT work, then there is a problem with the Electronics Module and should be replaced ⇒ Page 8-24.

- 3** Switch the Printer OFF and remove the LAN Card. Switch ON the Printer and check if it initializes completely. If it initializes correctly without any problems, then the problem could be with the Electronics Module and should be replaced ⇒ Page 8-24.
- 4** If the Printer does not even start to power up (i.e. nothing seen on the Front Panel and the LED in the Power Switch is NOT flashing) **without** the LAN Card nor the Formatter/Accessory Card, but the power switch LED is ON (all the time) the problem could be with the Electronics Module or the Power Supply Unit.
 - The red LED will flash a few times when the Printer is started up but if it stays lit (all the time) or flashes continuously, then this indicates that the Formatter/Accessory Card is faulty and should be replaced.

System Error Codes

2

Introduction	2-2
Continuable and Non-Continuable Error Codes	2-2
System Error Codes - Explanation	2-2
Accessing the Error Log Utility	2-5
01:10	2-7
01:11	2-7
01:12	2-7
01:13	2-8
02:10	2-8
02:13	2-8
03:10	2-9
04:11	2-9
05:10 Warning (Only applicable to HP DesignJet 800 Series)	2-9
05:11	2-10
08:11	2-10
11:11	2-10
11:13	2-10
12:11	2-10
21:10	2-11
21:11	2-11
22:10	2-11
41:10	2-11
41:13	2-12
42:10	2-12
43:10	2-12
43:11	2-12
56:10	2-12
56:13	2-13
61:04	2-13
61:05	2-14
64:04	2-14
71:04	2-15
71:06	2-15
72:04	2-16
73:04	2-16
79:04	2-17
81:01	2-17
81:11	2-17
85:10	2-18
86:01	2-18
86:11	2-18
86:13	2-19
87:13	2-19
93:10	2-19

Introduction

System error codes are hexa-decimal based numbers generally caused by internal system errors. The following pages contain a list of system error codes and their respective descriptions and recommended corrective actions. Only try one recommended action at a time and check if the error code has disappeared.

Continuable and Non-Continuable Error Codes

Some of the Error Codes are continuable, which means you can press **Enter** on the front-panel and continue working with the Printer. Non-Continuable Error Codes do not allow you to continue working with the Printer, in this case power the Printer OFF and ON again and see if the System Error disappears. If the Error Code reappears, then the Printer requires an on-site visit in order to resolve the problem.

NOTE

Even though the customer can continue working with a Continuable Error Code, an on-site visit should still be planned to troubleshoot the problem.

System Error Codes - Explanation

System Error Codes consist of 4 digits which explain which component/system is failing and what action should be taken to resolve the problem.

The following table explains the **first** 2 digits of the System Error Code:

Code	Component/System
01	Main PCA/Electronics Module
02	Carriage/Carriage PCA
03	Power Supply Unit
04	Network Card
05	Formatter
06	Hard Disk Drive
07	Interconnect PCA
08	Front Panel
11	Trailing Cable

Code	Component/System
12	Carriage Flex Circuit
17	Interconnect Cable
21	Service Station
22	Ink Supply Station
23	Pressure System (APS)
24	Ink Delivery System
25	Spittoon
31	Cutter
32	Take-up Reel
33	Sheet Feeder
34	Dryer/Blower
41	Paper-Axis Motor
42	Scan-Axis Motor
43	Vacuum Fan
44	Aerosol fan
51	Window Sensor
52	Drop Detector
53	Media Sensor
54	Pinch-Arm Sensor
55	Line Sensor
56	Drive Roller Encoder Sensor
57	Ink Leak Detector
58	Color Sensor
59	Media Type Sensor
61	Language Interpreting
62	Input/Output through Parallel Port
63	Input/Output through Network Card
64	Input/Output through USB Port
71	Memory Management
72	Generic Firmware
73	Servo

Code	Component/System
81	Media Advance
82	Media Cut
83	Single-Sheet Feeding
84	Roll Feeding
85	Media-Axis Encoder Reading
86	Carriage Movement
87	Scan-Axis Encoder Reading
91	Printhead Firing
92	Servicing
93	Ink Pumping

The following table explains the **last 2** digits of the System Error Code:

Code	Recovery Action	Response
01	Replace	Possible for customer to perform action
02	Reseat/Reconnect/Clean/Adjust (manually)	
03	Calibrate/Adjust (using Automatic Process)	
04	Power OFF	
05	Upgrade System Firmware	
06	Upgrade Driver	
07	Add Accessory	
09	Wrong Part Installed	
10	Replace	
11	Reseat/Reconnect/Clean/Adjust (manually)	
12	Calibrate/Adjust (using Automatic Process)	
13	Power OFF	
14	Upgrade System Firmware	
15	Upgrade Driver	
16	Add Accessory	
19	Wrong Part Installed	

Error Log Utility

The Error Log utility contains a record of the last 10 system error codes the Printer has experienced. The purpose of this information is to:

- Determine whether the Printer is experiencing repetitive failures.
- Determine whether the previous problems are causing the current failure in the printer.
- Determine whether there are additional symptoms to the current system error code.

The information that is stored for each error code is:

- The reported System error code.
- The code line in the Firmware where the error was triggered.
- The date when the error code was triggered.

Accessing the Error Log Utility

- 1 Press the \uparrow or \downarrow key until the front panel displays the Setup Menu and then press **Enter**.

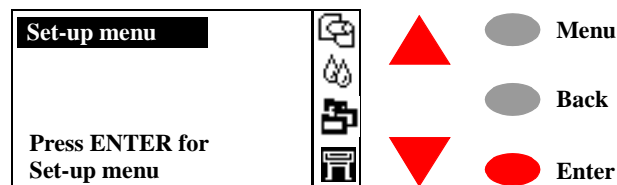

- 2 Press the \uparrow or \downarrow key until the front panel highlights **Log**. Press the **Enter** key.

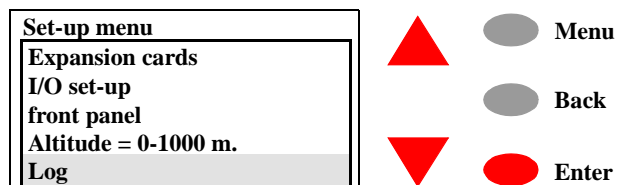

- 3 Press the ↑ or ↓ key until the front panel highlights **Errors**. Press the **Enter** key.

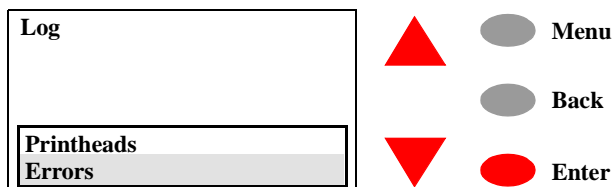

- 4 Press the ↑ or ↓ key until the front panel highlights the error code that you want to see information on. Press the **Enter** key.

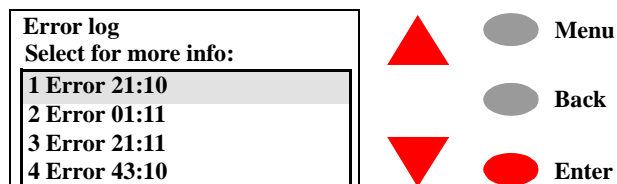

- 5 The front panel displays information on the selected item.

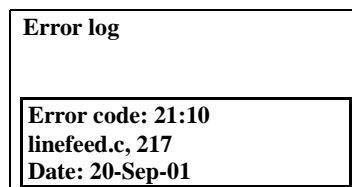

NOTE

To view information on another Error Code, press **BACK** and the front panel will return to the previous screen

System Error:	01:10
Problem Description:	Electronics Module failure. The possible cause could be: <ol style="list-style-type: none">1. <i>The Electronics Module is of the wrong type (a 16 MB Electronics Module will not work in a 24" Model).</i>2. <i>Reading, writing or initializing the EEROM failed.</i>3. <i>One of the ASIC's was not found within the Serial Bus that connects the Electronics Module to the Carriage Assembly.</i>4. <i>One of the ASIC's did not respond to the Serial Bus that connects the Electronics Module to the Carriage Assembly.</i>5. <i>The Electronics Module is requesting a move to the Service Station while the previous move is still being completed.</i>6. <i>The Electronics Module Cooling Fan has reached its current limit.</i>
Corrective Action:	Replace the Electronics Module ⇒ Page 8-24.

System Error:	01:11
Problem Description:	The Electronics Module Cooling Fan badly connected.
Corrective Action:	Reconnect the Cooling Fan (located on top of the Electronics Module). If the Cooling Fan continues to fail, check that the connector pins in the Electronics Module are NOT bent.

System Error:	01:12
Problem Description:	The EEROM is not configured correctly (the product number may be missing).
Corrective Action:	Configure the EEROM correctly using the EEROM setup utility ⇒ Page 4-16.

System Error: 01:13

Problem Description: Electronics Module failure. The possible cause could be:

1. *One of the ASIC's in the Electronics Module is reporting that it is too hot.*
2. *The interruptions from the Scan-Axis servo or from the Paper-Axis servo are not coming as regularly as they are expected or are coming too late.*

Corrective Action: Try the following:

- Switch the Printer Off and wait a few minutes. Switch the Printer On again and check if the Error Code has disappeared.
- If the Error Code continues, replace the Electronics Module ⇒ Page 8-24.

System Error: 02:10

Problem Description: Carriage failure. The possible cause could be:

1. *The Carriage PCA is not compatible with the rest of the Printer.*
2. *The Carriage ASIC has problems initializing.*
3. *The +2.5V reference voltage generated in the Carriage PCA is out of range.*
4. *One of the Carriage ASIC's cannot be found within the Serial Bus that connects the Electronics Module to the Carriage.*
5. *One of the Carriage ASIC's did not respond to the Serial Bus that connects the Electronics Module to the Carriage Assembly.*

Corrective Action: Replace the Carriage Assembly ⇒ Page 8-78.

System Error: 02:13

Problem Description: Carriage failure. The possible cause could be:

1. *One of the ASIC's in the Carriage is reporting that it is too hot.*

Corrective Action: Try the following:

- Switch the Printer Off and wait a few minutes. Switch the Printer On again and check if the Error Code has disappeared.
- If the Error Code continues, replace the Carriage Assembly ⇒ Page 8-78.

System Error:	03:10
Problem Description:	Power Supply failure.
Corrective Action:	Replace the Power Supply Unit ⇒ Page 8-27.

System Error:	04:11
Problem Description:	LAN Card not detected.
Corrective Action:	Power OFF the Printer and reconnect the LAN Card.

System Error:	05:09 Error (Only applicable to HP DesignJet 500 Series)
Problem Description:	Formatter installed instead of HP-GL/2 Accessory Card.
Corrective Action:	Power OFF the Printer and remove the Formatter and install the HP-GL/2 Accessory Card ⇒ Page 8-20.

NOTE: If this Error Code appears on a DesignJet 800 Series Printer, then the model number configured in the Printer is incorrect (the Printer thinks it's a DesignJet 500 Series Printer). In this case reconfigure the model number ⇒ Page 4-16.

System Error:	05:10 Warning (Only applicable to HP DesignJet 800 Series)
Problem Description:	Formatter not detected.
Corrective Action:	Power OFF the Printer and reseal the Formatter.

System Error:	05:10 Error (Only applicable to HP DesignJet 800 Series)
Problem Description:	Formatter failure.
Corrective Action:	Power OFF the Printer and replace the Formatter ⇒ Page 8-20.

System Error:	05:10 Error (Only applicable to HP DesignJet 500 Series)
Problem Description:	HP-GL/2 Accessory Card failure.
Corrective Action:	Power OFF the Printer and replace the HP-GL/2 Accessory Card ⇒ Page 8-20.

System Error Codes

System Error:	05:11
Problem Description:	Formatter not detected.
Corrective Action:	Power OFF the Printer and reconnect the Formatter.

System Error:	08:11
Problem Description:	Front Panel cannot be detected.
Corrective Action:	Reconnect the Front Panel.

System Error:	11:11
Problem Description:	Trailing Cable badly connected.
Corrective Action:	Reconnect the Trailing Cable correctly.

System Error:	11:13
Problem Description:	Problem with setting the voltage of the Printheads.
Corrective Action:	Try the following: <ul style="list-style-type: none">■ Check that the Trailing Cable is connected correctly at both ends.■ Replace the Trailing Cable ⇒ Page 8-40.■ Replace the Carriage Assembly ⇒ Page 8-78.

System Error:	12:11
Problem Description:	A short detected in the Carriage Assembly.
Corrective Action:	Try the following: <ul style="list-style-type: none">■ Remove ALL the Printheads and clean the flex contacts on the Printheads and in the Carriage Assembly.■ Replace ALL the Printheads.■ Replace the Carriage Assembly ⇒ Page 8-78.

System Error: 21:10

Problem Description: Service Station failure. The possible cause could be:

1. *The steps counted by the Service Station motor are not consistent with the expected length of the current movement.*
2. *The Aerosol Fan has reached its maximum current limit.*
3. *The Service Station motor has shutdown because of blockage.*

Corrective Action: Replace the Service Station/Aerosol Fan Assembly ⇒ Page 8-52.

System Error: 21:11

Problem Description: Service Station/Aerosol Fan cannot be detected or the Service Station is badly adjusted.

Corrective Action: Try the following:

- Reconnect the Service Station/Aerosol Fan Assembly.
- Reposition the Service Station trip lever.

System Error: 22:10

Problem Description: Ink Supply Station failure. The possible cause could be:

1. *Reading, writing or initializing the backup EEROM failed.*
2. *One of the out-of-ink sensors (located in the Ink Supply Station) is not reporting what it should during the initializing process while depressurizing.*

Corrective Action: Replace the Ink Supply Station ⇒ Page 8-48.

System Error: 41:10

Problem Description: Paper-Axis Motor failure.

Corrective Action: Replace the Paper-Axis Motor ⇒ Page 8-84.

System Error Codes

System Error: 41:13
Problem Description: Error in the Paper-Axis Motor Encoder quadrature.
Corrective Action: Try the following:

- Switch the Printer Off and wait a few minutes. Switch the Printer On again and check if the Error Code has disappeared.
- If the Error Code continues, replace the Paper-Axis Motor ⇒ Page 8-84.

System Error: 42:10
Problem Description: Scan-Axis Motor failure.
Corrective Action: Replace the Scan-Axis Motor ⇒ Page 8-29.

System Error: 43:10
Problem Description: Vacuum Fan failure.
Corrective Action: Replace the Vacuum Fan ⇒ Page 8-64.

System Error: 43:11
Problem Description: Vacuum Fan not detected.
Corrective Action: Reconnect the Vacuum Fan.

System Error: 56:10
Problem Description: Drive Roller Encoder Sensor error.
Corrective Action: Replace the Drive Roller Encoder Sensor ⇒ Page 8-38.

System Error:	56:13
Problem Description:	Error in the Drive Roller Encoder Sensor quadrature.
Corrective Action:	Try the following: <ul style="list-style-type: none">■ Switch the Printer Off and wait a few minutes. Switch the Printer On again and check if the Error Code has disappeared.■ If the Error Code continues, replace the Drive Roller Encoder Sensor ⇒ Page 8-38.

System Error:	61:04
Problem Description:	Firmware Error.
Corrective Action:	Try the following: <ul style="list-style-type: none">■ Switch the Printer Off and wait a few minutes. Switch the Printer On again and check if the Error Code has disappeared.■ If the Error Code reappears, check for a new Firmware release.■ If the new Firmware release does not solve the problem, or if new Firmware release was not available, then contact the HP Response Center (or directly to the Division) supplying the following information:<ul style="list-style-type: none">– Model and Serial Number of the Printer.– Firmware release of the Printer (use the Printer Information utility ⇒ Page 4-26).– The complete Error Code information, including the linefeed where the error occurred (use the Error Log utility to obtain this information ⇒ Page 2-5).

System Error:	61:05
Problem Description:	Error Processing Job. This Error Code only appears in HP DesignJets 800 Series, or in the HP DesignJet 500 Series with an HP-GL/2 card installed, when processing either a PostScript or HP-GL/2 file.
Corrective Action:	Try the following: <ul style="list-style-type: none">■ Switch the Printer Off and wait a few minutes. Switch the Printer On again and resend the file that you were trying to print.■ If the Error Code reappears after resending the file, then try generating the file again and try to print again.■ If the file that is causing this error is PostScript, check if it is Binary. If the file is Binary, use AppleTalk to send the file to the Printer. If AppleTalk is not being used to send the Binary file to the Printer, then change the PostScript settings to Binary through the Front Panel (<i>Set-up menu / PS settings / Encoding / Binary</i>).■ If the Error Code continues to reappear, check for a new release of the Driver.

System Error:	64:04
Problem Description:	Firmware Error (USB Port).
Corrective Action:	Try the following: <ul style="list-style-type: none">■ Switch the Printer Off and wait a few minutes. Switch the Printer On again and check if the Error Code has disappeared.■ If the Error Code reappears, check for a new Firmware release.■ If the new Firmware release does not solve the problem, or if new Firmware release was not available, then contact the HP Response Center (or directly to the Division) supplying the following information:<ul style="list-style-type: none">– Model and Serial Number of the Printer.– Firmware release of the Printer (use the Printer Information utility ⇒ Page 4-26).– The complete Error Code information, including the linefeed where the error occurred (use the Error Log utility to obtain this information ⇒ Page 2-5).

System Error:	71:04
Problem Description:	Problem allocating Memory. This Error Code only appears in HP DesignJets 800 Series, or in the HP DesignJet 500 Series with an HP-GL/2 card installed.
Corrective Action:	Try the following: <ul style="list-style-type: none">■ Switch the Printer Off and wait a few minutes. Switch the Printer On again and check if the Error Code has disappeared.■ If the Error Code reappears, check for a new Firmware release.■ If the new Firmware release does not solve the problem, or if new Firmware release was not available, then contact the HP Response Center (or directly to the Division) supplying the following information:<ul style="list-style-type: none">– Model and Serial Number of the Printer.– Firmware release of the Printer (use the Printer Information utility ⇒ Page 4-26).– The complete Error Code information, including the linefeed where the error occurred (use the Error Log utility to obtain this information ⇒ Page 2-5).

System Error:	71:06
Problem Description:	Out of Memory problem. This Error Code only appears in HP DesignJets 800 Series, or in the HP DesignJet 500 Series with an HP-GL/2 card installed, when processing either a PostScript or HP-GL/2 file.
Corrective Action:	Try the following: <ul style="list-style-type: none">■ Check the amount of RAM in the Printer using the Front Panel (use the Printer Information utility ⇒ Page 4-26). If necessary, install more memory into the Formatter.■ If the problem continues, try processing the file in the PC instead of the Printer (select Avoid out of memory in Advanced options in the Driver).

System Error: 72:04

Problem Description: Problem in the Scan-Axis (Firmware Error).

Corrective Action: Try the following:

- Switch the Printer Off and wait a few minutes. Switch the Printer On again and check if the Error Code has disappeared.
- If the Error Code reappears, check for a new Firmware release.
- If the new Firmware release does not solve the problem, or if new Firmware release was **not** available, then contact the HP Response Center (or directly to the Division) supplying the following information:
 - Model and Serial Number of the Printer.
 - Firmware release of the Printer (use the Printer Information utility ⇒ Page 4-26).
 - The complete Error Code information, including the linefeed where the error occurred (use the Error Log utility to obtain this information ⇒ Page 2-5).

System Error: 73:04

Problem Description: Servo Error.

Corrective Action: Try the following:

- Switch the Printer Off and wait a few minutes. Switch the Printer On again and check if the Error Code has disappeared.
- If the Error Code reappears, check for a new Firmware release.
- If the new Firmware release does not solve the problem then replace the Electronics Module ⇒ Page 8-24.
- If the problem continues, contact the HP Response Center (or directly to the Division) supplying the following information:
 - Model and Serial Number of the Printer.
 - Firmware release of the Printer (use the Printer Information utility ⇒ Page 4-26).
 - The complete Error Code information, including the linefeed where the error occurred (use the Error Log utility to obtain this information ⇒ Page 2-5).

System Error:	79:04
Problem Description:	Firmware Error.
Corrective Action:	Try the following: <ul style="list-style-type: none">■ Switch the Printer Off and wait a few minutes. Switch the Printer On again and check if the Error Code has disappeared.■ If the Error Code reappears, check for a new Firmware release.■ If the new Firmware release does not solve the problem, or if new Firmware release was not available, then contact the HP Response Center (or directly to the Division) supplying the following information:<ul style="list-style-type: none">– Model and Serial Number of the Printer.– Firmware release of the Printer (use the Printer Information utility ⇒ Page 4-26).– The complete Error Code information, including the linefeed where the error occurred (use the Error Log utility to obtain this information ⇒ Page 2-5).

System Error:	81:01
Problem Description:	Paper-Axis shutdown.
Corrective Action:	If this error code appeared but was NOT caused by a paper jam, then try the following: <ul style="list-style-type: none">■ Perform the Paper Advance Test ⇒ Page 4-10.

System Error:	81:11
Problem Description:	Paper-Axis shutdown (during the Paper Advance test).
Corrective Action:	Refer to Error Code 81:01.

System Error: 85:10

Problem Description: Paper-Axis Encoder error. The Drive Roller Encoder Sensor cannot find the zero position of the Encoder Disk.

Corrective Action: Try the following:

- Replace the Drive Roller Encoder Sensor ⇒ Page 8-38.
- If the Error Code continues, replace the Drive Roller ⇒ Page 8-86.

System Error: 86:01

Problem Description: Carriage-Axis shutdown.

Corrective Action: If this error code appeared but was NOT caused by a paper jam, then try the following:

- Too much friction in the Slider Rod. Enter the Printer Information utility (⇒ Page 4-26) and check the Scan-Axis usage. If the percentage is close to 100%, then lubricate the Slider Rod.
- The Carriage is bumping into the Service Station. If the carriage is stuck at the right hand side of the Printer and cannot be moved out to the center of the Print Platen it is because the Service Station cannot uncap the Printheads. In this case replace the Service Station/Aerosol Fan Assembly ⇒ Page 8-52.
- Perform the Carriage Movement test ⇒ Page 4-8.

System Error: 86:11

Problem Description: Carriage-Axis shutdown (during the Carriage Movement test).

Corrective Action: Refer to Error Code 86:01.

System Error:	86:13
Problem Description:	Carriage-Axis shutdown (Firmware Error).
Corrective Action:	Try the following: <ul style="list-style-type: none">■ Switch the Printer Off and wait a few minutes. Switch the Printer On again and check if the Error Code has disappeared.■ If the Error Code reappears, check for a new Firmware release.■ If the new Firmware release does not solve the problem, or if new Firmware release was not available, contact the HP Response Center (or directly to the Division) supplying the following information:<ul style="list-style-type: none">– Model and Serial Number of the Printer.– Firmware release of the Printer (use the Printer Information utility ⇒ Page 4-26).– The complete Error Code information, including the linefeed where the error occurred (use the Error Log utility to obtain this information ⇒ Page 2-5).

System Error:	87:13
Problem Description:	Unable to read the Carriage Encoder Sensor.
Corrective Action:	Try the following: <ul style="list-style-type: none">■ Switch the Printer Off and wait a few minutes. Switch the Printer On again and check if the Error Code has disappeared.■ If the Error Code continues, replace the Carriage Assembly ⇒ Page 8-78 or the Encoder Strip ⇒ Page 8-76.

System Error:	93:10
Problem Description:	Ink System startup failed (also see Page 1-7 for more information).
Corrective Action:	Try the following: <ul style="list-style-type: none">■ Check for a leak in the Printer. If a leak is evident (there is ink on Printer components), replace the Ink Supply Tubes ⇒ Page 8-60.■ Perform the Prime Tubes utility (Refer to Page 4-23) and check how long it takes to complete the procedure. If it takes too long to complete the procedure and there is no leak in the Printer, then replace the Ink Cartridges. If it takes a short time to complete the procedure, then replace the Ink Supply Tubes ⇒ Page 8-60.

Ink Supplies Troubleshooting

3

What are the Ink Supplies?	3-2
Ink Cartridges	3-2
Printheads	3-3
Identifying the Components	3-3
General Information About the Ink Supplies	3-4
Some General Precautions When Handling the Ink Supplies	3-5
When Should You Replace the Ink Cartridges?	3-6
When Should You Replace the Printheads?	3-7
Obtaining Ink Cartridge Information	3-9
Obtaining Printhead Information	3-10
Ink Cartridge Status Messages	3-12
Ink Cartridge Status While Replacing	3-12
Printhead Status Messages	3-13
Printhead History Utility	3-14
Accessing the Printhead History Utility	3-14
Is the Printer Causing Repetitive Printhead Problems?	3-16
Is the User Replacing the Printheads too Early?	3-18
Troubleshooting Repetitive Ink Cartridge Messages	3-20
Troubleshooting Repetitive Printhead Error Messages	3-21
Printhead Error Codes	3-22
Summary of Solving Ink Supplies Problems	3-23

What are the Ink Supplies?

For each of the four ink colors used in the Printer, there are two separate components: the Printhead and the Ink Cartridge. Both components are coded with an HP selection number to identify the correct replacement supplies.



Printhead



Ink Cartridge
69cc

Ink Cartridges

The Ink Cartridges for the HP DesignJet 500 and 800 Series Printers require no maintenance or cleaning. As long as each Ink Cartridge is inserted correctly into its slot, the ink will flow to the Printheads.

The Ink Cartridges are number coded as follows:

- **HP No.10** for the Black Ink Cartridge.
- **HP No.82** for the Cyan, Magenta and Yellow Ink Cartridges.

NOTE

It is also possible to use HP No.11 Ink Cartridges for the Cyan, Magenta and Yellow colors. The HP No.11 Ink Cartridges contain 33cc of ink.

The front panel displays the status of the Ink Cartridge. With the front panel, detailed information can be checked on the Ink Cartridges, see page Page 3-9, *Obtaining Ink Cartridge Information*.

Printheads

The Printheads are extremely durable and do not need to be replaced every time an Ink Cartridge is replaced. They are independent of the Ink Cartridges and will continue giving excellent image quality results even if the Ink Cartridges are low on ink. In order to know when to replace a Printhead, see page Page 3-7, *When Should You Replace the Printheads?*

The Printheads are number coded **HP No.11** for ALL colors.

If you notice a decline in print quality such as lines or dots missing from text / graphics, go to page Page 6-4, *Performing the Troubleshooting Procedure.*

Identifying the Components

The following illustration will help you identify the components of the ink supplies.



General Information About the Ink Supplies

For optimum results from the printer and modular ink delivery system always follow these guidelines when handling the ink supplies:

- Always install the Ink Cartridges and Printheads before the expiration date, which is on the packaging.
- Install Ink Cartridges and Printheads in their color-coded slots.
- Follow the instructions on the front panel of the Printer during installation.
- Avoid unnecessary removal of the Ink Cartridges and Printheads.
- When turning off the Printer always use the power Off button located on the left hand side of the Printer. The Printheads are then stored correctly which prevents them from drying out.
- The Ink Cartridges should never be removed while the Printer is printing. They should only be removed when the Printer is ready for you to replace them. The front panel will guide you through the removal and installation procedure. See page Page 3-6, *When Should You Replace the Ink Cartridges?*

Some General Precautions When Handling the Ink Supplies

CAUTION



Do not touch, wipe or attempt to clean the Printhead nozzles. This can damage the Printhead.

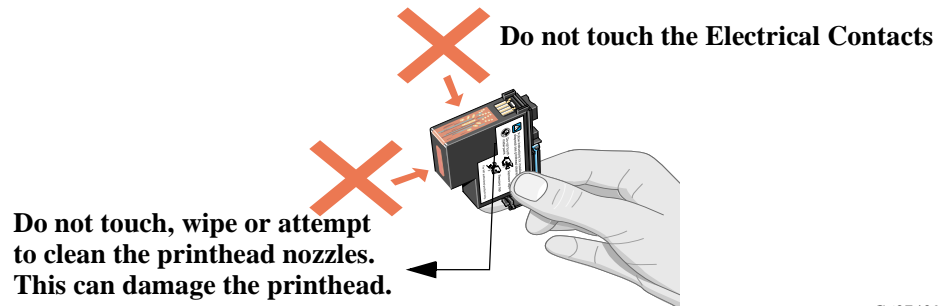

C6074297a

Handle the Ink Supplies with care. In particular the Printhead, which is a high precision device, must be handled very carefully.

- Do not touch the Printhead nozzles.
- Do not touch the Electrical contacts on the Printhead.
- Do not put the Printhead down on the nozzles.
- Do not be rough when handling the Printheads. Always set them down gently.
- Do not drop the Printheads.
- Proper handling will assure optimum performance throughout the Printhead life.
- Do not touch the end of the Ink Cartridge which is inserted into the Printer as there may be a small amount of ink on the connection.
- Avoid storing partially used Ink Cartridges on their ends.

When Should You Replace the Ink Cartridges?

When to change the Ink Cartridges is mostly determined by you with guidance from the front panel. In conjunction with the messages displayed in the front panel and the message explanations in this chapter, you will be able to choose for yourself when is the right time to change the Ink Cartridges.

The printer will also display the ink level and will tell you when the Ink Cartridge is almost empty. This means you have constantly updated information about the Ink Cartridges.

There are 3 circumstances when you need to replace the Ink Cartridges which are explained as follows:

- **Ink Cartridge Error message.** When this message appears, the Ink Cartridge has experienced a problem and should be replaced. If this message appears repetitively, refer to Page 3-20, *Troubleshooting Repetitive Ink Cartridge Messages*.



- **Out of Ink message.** When this message appears, the Ink Cartridge is out of ink and should be replaced. If this message appears repetitively, refer to Page 3-20, *Troubleshooting Repetitive Ink Cartridge Messages*.



- **Expiration message.** When this message appears, the Printer is warning you that the Ink Cartridge is close to the expiration date. Once the expiration date has been reached, the Printer will stop working and you will need to install a new Ink Cartridge in order to proceed. If this message appears repetitively, refer to Page 3-20, *Troubleshooting Repetitive Ink Cartridge Messages*.



When Should You Replace the Printheads?

In a normal situation, the Printhead should **ONLY** ever be replaced when advised by the Printer. If Print Quality is poor, the first step should **ALWAYS** be to perform the **Troubleshooting** procedure (Refer to Page 6-4) which will determine whether the Printhead needs replacing or not after performing various levels of recovery actions.

The minimum life expectancy of the Printhead is anticipated to be 530cc for the Black Printhead and 200cc for the Color Printheads, provided that the Printhead is used under normal operating conditions (using HP Ink Cartridges only) and its “install before date” has not lapsed. However results vary depending on the print quality setting being used.

There are 3 circumstances when you need to replace the Printheads which are explained as follows:

- **Printhead Error message.** When this message appears, the Printer has determined that one of the Printheads has experienced a problem and should be replaced. If this message appears repetitively, refer to Page 3-21, *Troubleshooting Repetitive Printhead Error Messages*.



- **Printhead Error (unknown) message.** When this message appears, one of the Printheads has experienced a problem but the Printer does not know which one it is.



In order to identify and replace the failing Printhead, try the following:

- 1 Select replace Printheads from the front panel.
- 2 Open the Carriage cover and remove **ALL** the Printheads.

- 3 Reinsert the Cyan Printhead only and close the Carriage cover and the Window.
 - 4 Check the front panel - if the status of the Cyan Printhead is **X** or **?** then the conclusion is that the Cyan Printhead is faulty and must be replaced. If the status of the Cyan Printhead is OK the conclusion is that the Cyan Printhead is working correctly. Repeat the process from **step 1** for the other Printheads to identify which one is failing.
- **Printhead Warning message.** When this message appears (normally appears when you check the status of the Printheads by selecting the **Ink Menu**), the Printer has determined that one of the Printheads has worn out and should be replaced.



The Printer normally determines this when:

- 1 The Printhead Alignment fails due to a faulty Printhead and the Printer tries to recover the Printhead (upto 3 times) but is not successful after the 4th attempt at the Printhead Alignment (or if the recovery process or the Printhead Alignments are cancelled).
- 2 The Troubleshooting process is performed but the Printer cannot recover the failing Printhead even after performing the maximum recovery action.

NOTE

The user can continue using the Printer even with the Printhead Warning message but will not get the maximum Print Quality that the Printer is designed to provide, unless he replaces the worn out Printhead.

Obtaining Ink Cartridge Information

- 1 To get information on the Ink Cartridges press the \uparrow or \downarrow key until the front panel displays the **Ink Menu**. Press the **Enter** key.

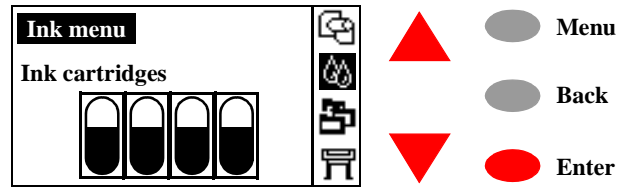

- 2 Press the \uparrow or \downarrow key until the front panel highlights **Information**. Press the **Enter** key.

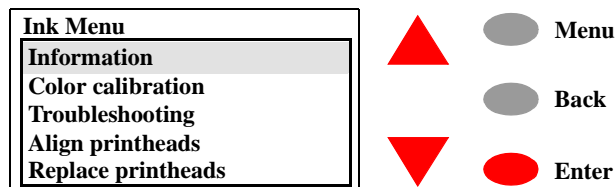

- 3 Press the \uparrow or \downarrow key until the front panel highlights **Ink cartridges**. Press the **Enter** key.

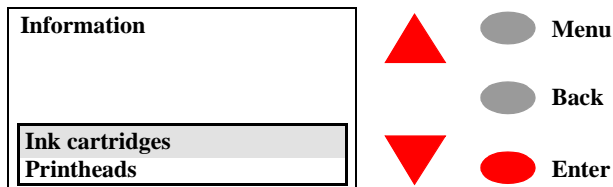

- 4 Press the \uparrow or \downarrow key until the front panel highlights the color that you want to see information on. Press the **Enter** key.

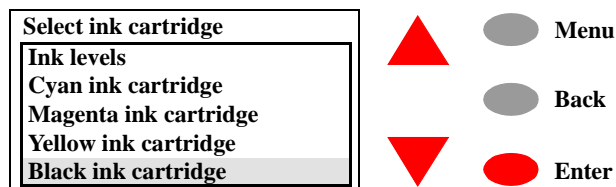

- 5 The front panel displays information on the selected Ink Cartridge.

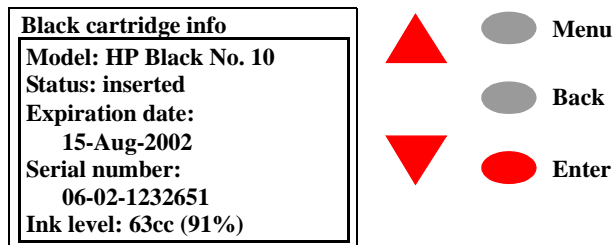

The information displayed is:

- The model of the Ink Cartridge (No.10 for Black and No.82 for the Colors is recommended).
- Status of the Ink Cartridge.
- The warranty expiration date of the Ink Cartridge.
- The Serial Number of the Ink Cartridge.
- The amount of ink remaining in the Ink cartridge (the error of the ink level can be as much as + or - 25% according to the specifications of the Printer).

Obtaining Printhead Information

- 1 To get information on the Printheads press the \uparrow or \downarrow key until the front panel displays the **Ink Menu**. Press the **Enter** key.

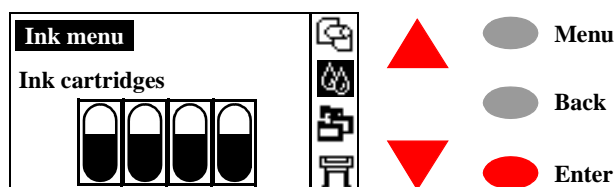

- 2 Press the \uparrow or \downarrow key until the front panel highlights **Information**. Press the **Enter** key.

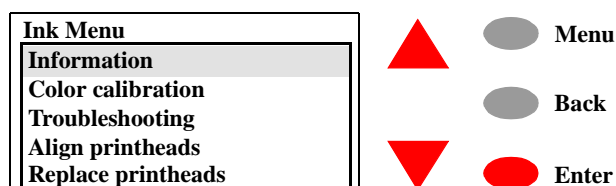

- 3 Press the \uparrow or \downarrow key until the front panel highlights **Printheads**. Press the **Enter** key.

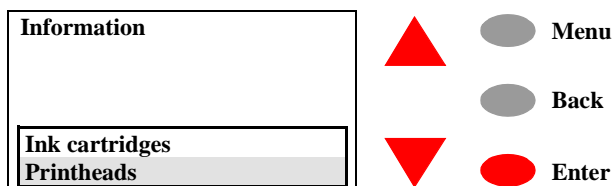

- 4 Press the \uparrow or \downarrow key until the front panel highlights the color that you want to see information on. Press the **Enter** key.

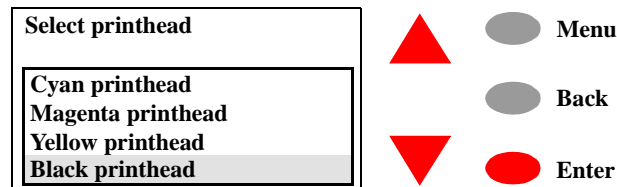

- 5 The front panel displays information on the selected Printhead.

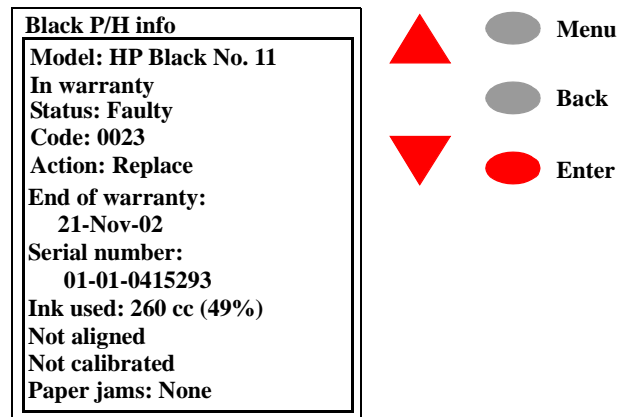

The information displayed is:

- The Model of the Printhead (HP No.11 is recommended).
- Whether the Printhead is In Warranty or Out of Warranty.
- Status of the Printhead (whether it is inserted, faulty, worn out or unknown).
- Printhead Error Code (if Printhead is faulty) - Refer to Page 3-22.
- The action required depending on the status of the Printhead.
- The end of warranty date of the Printhead.
- The Serial Number of the Printhead.
- How much ink has been consumed by the printhead. **Note:** It is possible for a Printhead to consume more than one Ink Cartridge. Also the % indicates the percentage over the expected life of the Printhead BUT a Printhead may last more than 100%.
- Whether the Printhead Alignment has been performed since the last Printhead replacement.
- Whether Color Calibration has been performed since the last Printhead replacement.
- Whether a Paper Jam was ever detected while this particular Printhead was installed.

Ink Cartridge Status Messages

Status Bars

The front panel displays four vertical bars. These bars represent how much ink is remaining in the Ink Cartridges: as ink is used up the bars get shorter in length. To see how much ink you have remaining, see page *Page 3-9, Obtaining Ink Cartridge Information*.

Ink Cartridge Status While Replacing

There are two circumstances under which you may need to replace an Ink Cartridge:

- The Printer has detected that the Ink Cartridge is empty or faulty.
- You decide to replace the Ink Cartridge.

If the printer detects that an Ink Cartridge needs replacing, you will see the message:



with six icons (explained below), referring from left to right to the Cyan (●), Black (●), Magenta (●) and Yellow (●) Ink Cartridges.

The icons may be any of the following:



The Ink Cartridge is **OK**; the approximate level of the ink is indicated - a full cartridge has the whole interior black;



Flashing; the Ink Cartridge is **missing**, and the correct one must be inserted;



Flashing exclamation mark; the Ink Cartridge is **low on ink**, and needs replacing at the earliest opportunity; For some types of Prints (like line drawings) the Ink Cartridge may still last much longer.



Flashing pump; the Ink Cartridge is **out of ink**, and must be replaced before any further printing can be done;



Flashing cross; the wrong Ink Cartridge is installed, and must be replaced before any further printing can be done.



Sand Clock; the Ink Cartridge will expire in X amount of days. The X is displayed at the top of the screen.

Printhead Status Messages

There are two circumstances under which you may need to replace a Printhead:

- The Printer has detected that the Printhead is faulty or is of the wrong model type.
- During the Printhead Alignment or **Troubleshooting** procedure the Printhead could not be recovered and the customer thinks that the Print Quality is not good enough.

Also, you should remove the Printheads if the Printer needs to be transported to another location.

If the Printer detects that a Printhead needs replacing, you will see the message:



with five icons (explained below), referring from left to right to the Cyan (C), Black (K), Magenta (M) and Yellow (Y) Printheads.

The icons may be any of the following:



The Printhead is **OK**;



Empty box flashing; the Printhead is **missing**, and the correct one must be inserted;



Flashing cross; the Printhead is **faulty** or is of the **wrong model type**; Reseat the Printhead and check if the problem is resolved. If not, replace the Printhead.



Exclamation Mark; the Printer has determined that one of the Printheads has worn out and should be replaced; Replace the Printhead (the user can still decide if the Print Quality is good enough for them).



Question Mark; one of the Printheads has experienced a problem but the Printer does not know which one it is. Refer to Page 3-7 to determine which Printhead has failed.

Printhead History Utility

The Printhead History utility contains information on the last 5 set of Printheads installed in the Printer. The purpose of this information is to:

- Determine whether the Printer is causing repetitive problems to the Printheads ⇒ Refer to Page 3-16.
- Determine whether the Customer is replacing the Printheads too early without trying to perform any recovery actions ⇒ Refer to Page 3-18.

The information that is stored for each Printhead is:

- How much ink was consumed when the Printhead was replaced.
- How long the Printhead was installed in the Printer.
- Whether the Printhead was in or out of warranty when it was removed.
- Whether the Printhead experienced a paper crash.
- Whether the Customer performed the right level of Printhead recovery (**Troubleshooting** procedure) before replacing a Printhead.
- The date when the Printhead was removed from the printer.
- The reported Error Code (if any).

Accessing the Printhead History Utility

- 1 Press the ↑ or ↓ key until the front panel displays the Setup Menu. Press the **Enter** key.

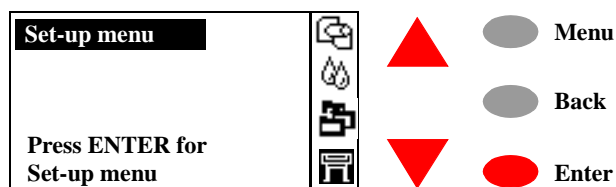

- 2 Press the ↑ or ↓ key until the front panel highlights **Log**. Press the **Enter** key.

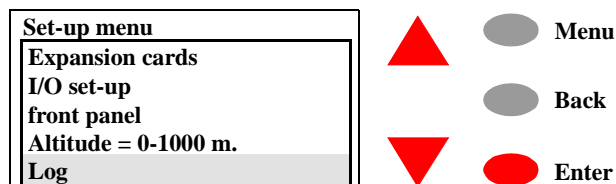

- 3 Press the \uparrow or \downarrow key until the front panel highlights **Printheads**. Press the **Enter** key.

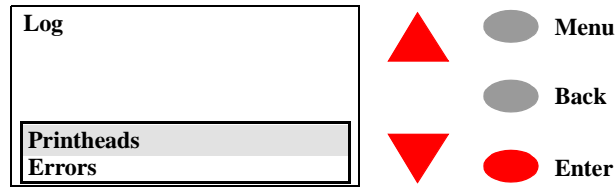

- 4 Press the \uparrow or \downarrow key until the front panel highlights the color that you want to see information on. Press the **Enter** key.

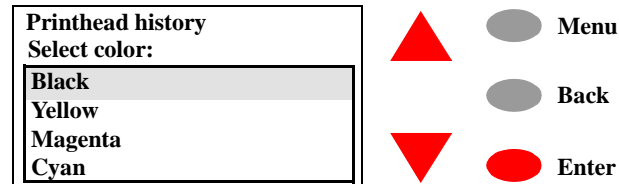

- 5 The front panel displays the history of the last 5 Printheads of the selected color (use the arrow keys to scroll through the complete list). Press the \uparrow or \downarrow key until the front panel highlights the item number that you want to see information on. Press the **Enter** key.

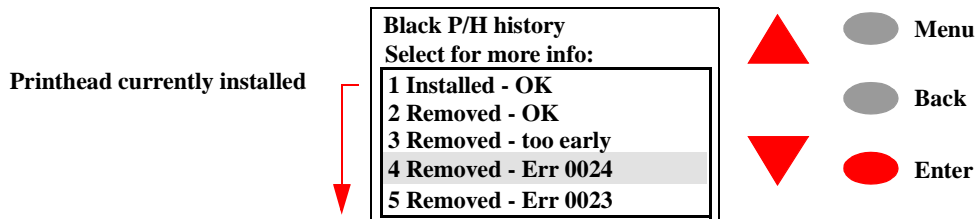

The status displayed for the last 5 Printheads could be any of the following:

- **Installed - OK:** A Printhead is currently installed in the Printer and no error is detected.
- **Installed - Err xxxx:** A Printhead is currently installed in the Printer and an error has been detected. For Printhead error codes, refer to Page 3-22.
- **Installed - Unknown:** The status of the installed Printhead is unknown.
- **Removed - OK:** The Printhead was replaced correctly after the minimum life expectancy of the Printhead was reached, without any error being reported.
- **Removed - too early:** The Printhead was replaced before the

minimum life expectancy of the Printhead was reached and without any error being reported.

- **Removed - Unknown:** The status of the replaced Printhead was unknown.
 - **Removed - Err xxxx:** The printhead was replaced after being marked with an error code. For Printhead Error Codes, refer to Page 3-22.
- 6 The front panel displays information on the selected item.

PH Info - Black #4
Ink used: 260 cc (49%)
Usage time: 135 days
P/H cleaning: 0
Error code: 0025
Removal date: 20-Sep-01

The information displayed is:

- The amount of ink the Printhead has consumed.
- The number of days the Printhead has been installed in the Printer.
- A code indicating whether Printhead recovery (**Troubleshooting** procedure) has been performed or not:
 - **0** indicates that the Printhead recovery was **never** performed.
 - **1** indicates that a Level 1 (soft) recovery was performed.
 - **2** indicates that a Level 2 (medium) recovery was performed.
 - **3** indicates that a Level 3 (hard) recovery was performed. **3** is the maximum recovery level that the Printer can perform before asking the customer to replace the Printhead.
- The reported Error Code (if any).
- The date the Printhead was removed from the Printer.

Is the Printer Causing Repetitive Printhead Problems?

The minimum life expectancy of the Printheads is 530cc for the Black Printhead and 200cc for the Color Printheads. If Print Quality is poor **before** the minimum life expectancy of the Printhead has been reached, the **Troubleshooting** procedure should be performed (Refer to Page 6-4) which will determine whether the Printhead needs replacing or not after performing various levels of recovery actions. After performing a recovery action, the Printhead will be encoded with either **1**, **2** or **3** (depending on the strength of the recovery action performed).

Now, if a Printhead is removed (even after Level 3 recovery has been performed) and the minimum life expectancy has **not been** reached, the Printhead will be marked "Removed - too early".

If a customer complains about having to replace the Printheads frequently **before** the minimum life expectancy has been reached, using the information obtained with the Printhead History Utility you can determine if the Printer is causing repetitive problems to the Printheads as follows:

- 1 Enter the Printhead History Utility and Select the color of the Printhead that is experiencing the replacement problem. In the following example, Printheads 2, 3 and 4 were removed too early:

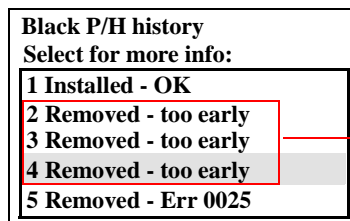

These 3 Printheads were removed from the Printer before the minimum life expectancy was reached.

- 2 In order to check if the recovery process (**Troubleshooting** procedure) was performed on each Printhead, select the Printhead and press the **Enter** key.

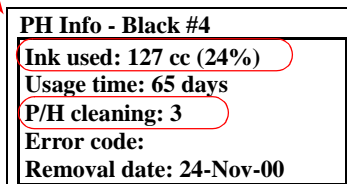
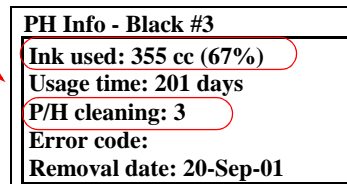
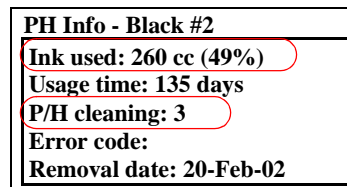
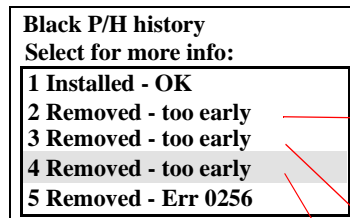

Summary
If 3 or more Printheads have been removed too early and the P/H cleaning code for all of them is 3 then try the troubleshooting steps on the following page.

As you can see in the above example, all the Printheads were removed **before** the minimum life expectancy was reached (Ink

used is below 100%) and the maximum recovery action was also performed (P/H cleaning code is **3**). Therefore the conclusion is that the Printer is causing the Printheads to fail. In this situation, to resolve the problem, try the following:

- 1** Check the amount of ink used by the Printhead (Page 3-10, *Obtaining Printhead Information*). If the amount of ink used by the Printhead is less than 1 Ink Cartridge (69 cc), then replace the Ink Cartridge for that color.
- 2** Check if the Ink Supply Station is faulty by performing the Ink Supply Station test ⇒ Page 4-6. If the test fails, replace the Ink Supply Station ⇒ Page 8-48.
- 3** Use the printer Information utility to check the usage of the Service Station ⇒ Page 4-26. If the usage of the Service Station is close to 100% then replace the Service Station ⇒ Page 8-52.
- 4** Check if the Ink Supply Tubes are faulty by installing new Start-up Printheads into the Carriage and see if ink flows to them (you will need to perform the Prime Tubes Utility ⇒ Page 4-23). If the ink **DOES NOT** flow to the Start-up Printheads, replace the Ink Supply Tubes ⇒ Page 8-60.

Is the User Replacing the Printheads too Early?

In the same way that you can determine if the Printer is causing failures in the Printheads, you can determine if the customer is replacing the Printheads **before** the minimum life expectancy has been reached **without** performing the maximum recovery action (**Troubleshooting** procedure).

If the user replaces the Printhead **without** performing a recovery action, the Printhead will be marked **0**. If the user replaces the Printhead after **only** performing Levels 1 or Level 2 recovery action, the Printhead will be marked **1** or **2**.

If a customer complains about having to replace the Printheads frequently **before** the minimum life expectancy has been reached due to poor print quality, using the information obtained with the Printhead History Utility you can determine if the Customer is replacing the Printheads too early as follows:

- 1** Enter the Printhead History Utility and Select the color of the Printhead that is experiencing the replacement problem. In the

following example, Printheads 2, 3 and 4 were removed too early:

Black P/H history	
Select for more info:	
1	Installed - OK
2	Removed - too early
3	Removed - too early
4	Removed - too early
5	Removed - Err 0025

These 3 Printheads were removed from the Printer before the minimum life expectancy was reached.

- In order to check if the maximum recovery process (**Troubleshooting** procedure) was performed on each Printhead, select the Printhead and press the **Enter** key.

Black P/H history	
Select for more info:	
1	Installed - OK
2	Removed - too early
3	Removed - too early
4	Removed - too early
5	Removed - Err 0025

PH Info - Black #2	
Ink used:	260 cc (49%)
Usage time:	135 days
P/H cleaning:	0
Error code:	
Removal date:	20-Feb-02

PH Info - Black #3	
Ink used:	355 cc (67%)
Usage time:	201 days
P/H cleaning:	0
Error code:	
Removal date:	20-Sep-01

PH Info - Black #4	
Ink used:	127 cc (24%)
Usage time:	65 days
P/H cleaning:	1
Error code:	
Removal date:	24-Nov-00

Summary
 If consecutive Printheads are being replaced too early and the P/H cleaning code for all of them is **2** or lower, the customer should be advised to use the **Troubleshooting** procedure before replacing Printheads.

As you can see in the above example, all the Printheads were removed **before** the minimum life expectancy was reached (Ink used is below 100%) and the maximum recovery action **was not** performed (P/H cleaning code is **0**, **1** or **2**). Therefore the conclusion is that the Printer is OK and the problem is that the customer is replacing the Printheads too early. In this case advise the customer to use the **Troubleshooting** procedure (refer to Page 6-4) to determine if Printheads need replacing or not. Emphasize that performing the **Troubleshooting** procedure could recover the Printhead if it is printing badly, therefore the User wouldn't need to buy new Printheads frequently.

Troubleshooting Repetitive Ink Cartridge Messages

When you see the messages shown below, the normal procedure is to replace the Ink Cartridge that has failed, ran out of ink or has expired.



But in certain circumstances, even after replacing the Ink Cartridge, the above messages continue to appear. This could mean that one of the components of the Printer is failing and requires cleaning or replacing. Follow these instructions to troubleshoot each message:

Ink Cartridge Error message.

- 1 Replace the Ink Cartridge that has failed.
- 2 If the message continues to appear, clean the electrical contacts inside the Ink Supply Station (power OFF the Printer first).
- 3 If the message continues to appear after cleaning the Ink Supply Station, replace the Ink cartridge again.
- 4 If the message still continues to appear, replace the Ink Supply Station ⇒ *Page 8-48*.

NOTE

You could also get repetitive Ink Cartridge Error messages if the Ink Cartridge is leaking. In this case try the following:

- 1 Reinsert the failing Ink Cartridge and if the status is OK, you may continue to print. If after reinserting the Ink Cartridge fails again then replace the Ink Cartridge. If the message continues to appear after replacing the Ink Cartridge then replace the Ink Supply Tubes ⇒ *Page 8-60*.

Out of Ink message.

- 1 Replace the Ink Cartridge that has failed.
- 2 If the message continues to appear, replace the Ink Cartridge again. If the new Ink Cartridge is consumed too quickly then the Ink Supply Tubes could be broken in which case replace the Ink Supply Tubes ⇒ *Page 8-60*.
- 3 If the message still continues to appear, perform the Ink Supply Station test ⇒ *Page 4-6*. If the test fails, replace the Ink Supply Station ⇒ *Page 8-48*.

Expiration message.**NOTE**

In order to determine the correct date, the Printer reads the information sent with a print file which includes the current date. The printer will then compare this date to the expiration date on the Ink Cartridge.

- 1 Replace the Ink Cartridge that has reached the expiration date.
- 2 Check the expiration date of the Ink Cartridge, see page Page 3-9, *Obtaining Ink Cartridge Information*. If, for example, today's date is 02-Nov-00 and the expiration date of the Ink Cartridge is 07-Jun-01, then the customer's computer should be checked to see if the correct date is configured.

Troubleshooting Repetitive Printhead Error Messages

When you see the message shown below, the normal procedure is to replace the Printhead that has failed.



But in certain circumstances, even after replacing the Printhead the above message continues to appear. This could mean that one of the components of the Printer is failing and requires cleaning or replacing. Follow these instructions to troubleshoot the message:

Printhead Error message.

- 1 Replace the Printhead that has failed.
- 2 If the message continues to appear, clean the electrical contacts inside the Carriage Assembly (power OFF the Printer first) and the electrical contacts of the Printhead (make sure you use water based solutions only).
- 3 If the message continues to appear after cleaning the Carriage Assembly and the Printhead, replace the Printhead again.
- 4 If the message still continues to appear, replace the Carriage Assembly ⇒ *Page 8-78*.

Printhead Error Codes

Printhead Error Codes consist of 4 digits which explain whether a Printhead is In or Out of Warranty and what problem has caused the Printhead to fail.

The following table explains the **first** 2 digits of the Printhead Error Code:

Code	Explanation
00	Black Printhead In Warranty
01	Magenta Printhead In Warranty
02	Cyan Printhead In Warranty
03	Yellow Printhead In Warranty
10	Black Printhead Out of Warranty
11	Magenta Printhead Out of Warranty
12	Cyan Printhead Out of Warranty
13	Yellow Printhead Out of Warranty

The following table explains the **last** 2 digits of the Printhead Error Code:

Code	Explanation
02 to 09	Acumen Error - Replace faulty Printhead only.
10, 12, 14, 16, 25, 26 and 28	Printhead Error - Replace faulty Printhead, clean Carriage and Printhead flex circuit, replace Carriage Assembly.
18, 19, 23 and 24	Printhead Error - Reseat faulty Printhead, replace faulty Printhead, clean Carriage and Printhead flex circuit.
27	Printhead Error - Printhead will die soon.
29	Acumen Error - Replace faulty Printhead, check other Printheads or Cartridges (only if all Printheads fail with this Error Code).

NOTE

Try the above recommended actions one at a time and check if the problem disappears.

Summary of Solving Ink Supplies Problems

Most of the problems that you could encounter when working with the Ink Supplies are solved with guidance from the front panel.

Problems reseating the Printhead

If you have inserted the printhead into the Carriage Assembly and the Printer rejects it (displays a faulty or missing icon), try the following steps.

NOTE

Check that during the priming process, the Setup Printheads are installed in the Carriage. If the printing Printheads are installed in the carriage during the priming process, they will be rejected and the front panel will show the "Normal printheads found - Open window and replace with SETUP printheads" message.

- Check that you have removed the protective tape from the printhead.
- Insert the Printhead into the Carriage Assembly but this time close the cover using the latch.
- Clean the electrical contacts on both the Printheads and the Carriage Assembly using a damp cloth.
- Replace the Printhead with a new one.

You Cannot Insert the Ink Cartridge Into the Printer

- 1 Ensure that you have the correct HP Ink Cartridge that is suitable for the HP DesignJet 500/800 Series Printer.
- 2 Ensure that the Ink Cartridge is the correct color for that slot.
- 3 Ensure that the Ink Cartridge is in the correct orientation, with the color coded label at the top.

CAUTION

Never clean inside the Ink Cartridge slots.

You Cannot Insert the Printhead Into the Printer

- 1 Ensure that you have the correct HP Printhead that is suitable for the HP DesignJet 500/800 Series Printer.
- 2 Ensure that the printhead is the correct color for that slot.
- 3 Ensure that the printhead is in the correct orientation.
- 4 Ensure that the protective cap is removed from the Printhead.

NOTE

Do not touch, wipe or attempt to clean the Printhead nozzles. This can damage the Printhead and reduce print quality.

Service Tests and Utilities

4

Introduction	4-2
Diagnostics - Self Test	4-2
Service Tests (Diagnostics)	4-3
Entering the Service Tests Menu	4-4
Ink Supply Station	4-6
Carriage Movement	4-8
Paper Advance Test	4-10
Service Utilities	4-13
Entering the Service Utilities Menu	4-14
EEROM Setup	4-16
Turn Drive Roller	4-21
Unlock Carriage	4-22
Prime Tubes	4-23
Change Cutter	4-24
Change Ink Tubes	4-25
Printer Information	4-26

Introduction

This chapter explains how to use the built-in Service Tests and Service Utilities and what to do if any of the Service Tests fail. If possible, always perform a Service Test on the component that you are about to replace, just to make sure that is the component that has failed. If the test on that component passes, there is no need to replace it.

Phone Support

PHONE SUPPORT

In certain circumstances, a Call Agent can try and troubleshoot the Printer by requesting the Customer to perform a Service Test via the phone. Using this process, it can be determined whether the Printer requires any on-site maintenance.

Diagnostics - Self Test

Initialization Sequences

Whenever the Printer is switched ON, it automatically performs a series of internal self tests and mechanical initialization sequences. If any of the parts fail, a system error will appear and you should consult Chapter 2 - *System Error Codes*.

Entering Service Menu at Power Up - Only for Onsite Repair

If the Printer fails to initialize completely because of a System Error and you need to use the Service Menu (Service Tests and Utilities), the Printer can be powered up in Service Mode by pressing the **Up** and **Enter** keys while switching the Printer ON. This will give you access to some of the Service Tests and Utilities without having to complete the System Initialization (if you perform some of the tests, they will need to initialize the relevant part of the System).

Service Tests (Diagnostics)

The following is a list of all internal Service Tests available in the Printer. Instructions for entering the Service Tests menu are given on Page 4-4.

1 Ink Supply Station ⇒ Page 4-6

The purpose of this test is to verify the operation of the Ink Supply Station. A failure of the out-of-ink sensors or the springs in the Ink Supply Station will eventually damage the Printheads because the Printer will try to pump ink from an empty Ink Cartridge stall, which will cause the Printhead to dry-fire.

2 Carriage Movement ⇒ Page 4-8

The purpose of this test is to verify the movement of the scan-axis components at several speeds. This test checks for the following problems:

- Friction problems with worn out slider rod or Carriage Bushings.
- Blockage due to problems with the Service Station.
- Problems with encoder sensing.

3 Paper Advance ⇒ Page 4-10

The purpose of this test is to identify whether there is too much friction in the paper-axis drive system which is caused by defects with the Transmission Gears, Drive Roller or the Paper-Axis Motor.

4 Troubleshooting ⇒ Page 6-4

The Printer contains an internal **Troubleshooting** procedure which helps you to diagnose and resolve the possible source of any Image Quality or Line Quality defects. If Print Quality is poor **at anytime**, the **Troubleshooting** procedure should be performed which will determine whether the Printhead needs replacing (by marking it with an exclamation mark) or not after performing various levels of recovery actions.

Entering the Service Tests Menu

NOTE

In order to enter the Service Utility Menu, please refer to the instructions on Page 4-14.

- 1 Press the \uparrow or \downarrow key until the front panel displays the Setup Menu and then press **Enter**.

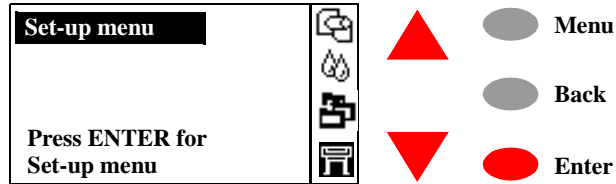

- 2 Once inside the Setup Menu, Press the following key combination to access the special Service Menu.

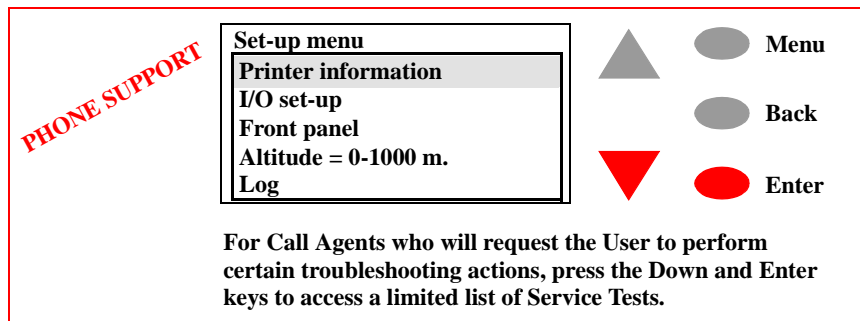
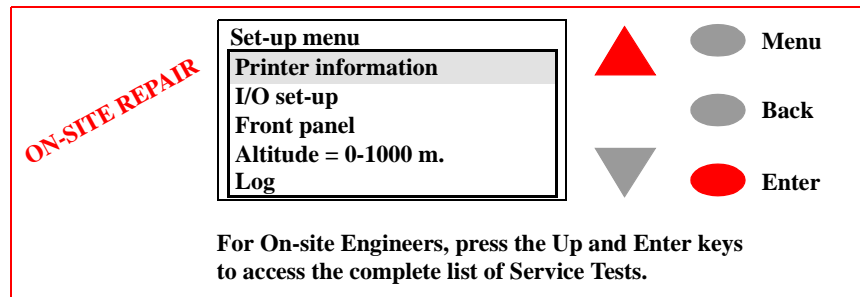

- 3 Once inside the Service Tools Menu, press the \uparrow or \downarrow key until the front panel displays **Service Tests** and then press **Enter**.

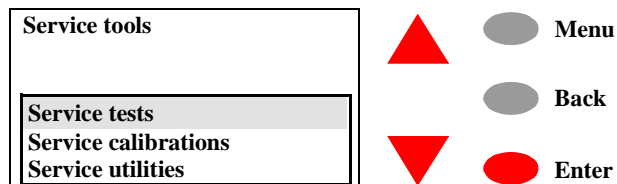

- 4 Press the **Enter** key to begin a specific test when the required Service Test is highlighted.

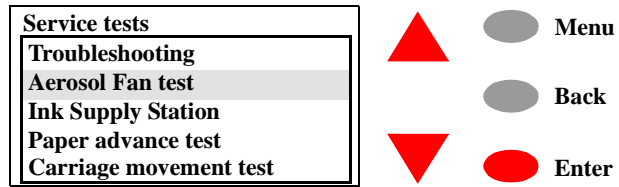

PHONE SUPPORT

Ink Supply Station

The purpose of this test is to verify the operation of the Ink Supply Station. A failure of the out-of-ink sensors or the springs in the Ink Supply Station will eventually damage the Printheads because the Printer will try to pump ink from an empty Ink Cartridge stall, which will cause the Printhead to dry-fire.

NOTE

This Service Test can be performed by the End User with the guidance of a HP Support person via the phone.

WARNING

IF POSSIBLE ALWAYS PERFORM THIS TEST BEFORE REPLACING THE INK SUPPLY STATION. IF THIS TEST PASSES, DO NOT REPLACE THE INK SUPPLY STATION.

Perform the Ink Supply Station test as follows:

- 1 In the Service Tests submenu, scroll to "Ink Supply Station" and press **Enter**.

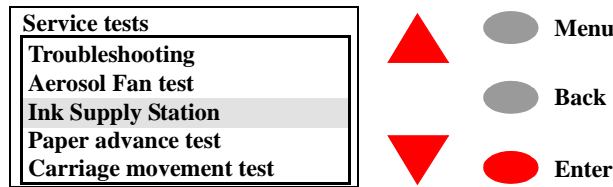

- 2 Once the test starts, the following message will appear on the Front Panel. Open the Ink Cartridge door and remove ALL the Ink Cartridges:

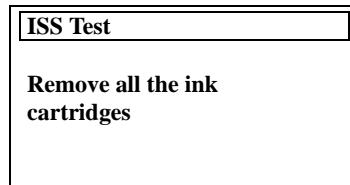

- 3 Once all the Ink Cartridges are removed the Printer will check the Ink Supply Station. During this short period, the following message will be displayed:

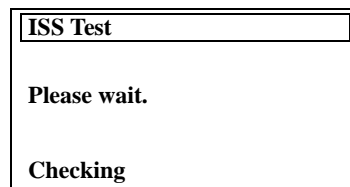

- 4 If the Printer detects **all** the out-of-ink signals, the Ink Supply Station has passed the test and the following message will appear on the Front Panel:

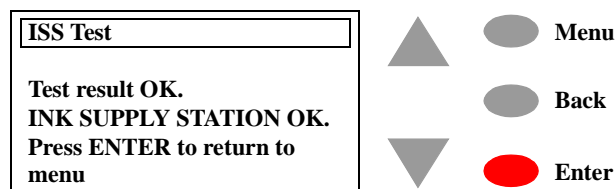

WARNING

IF THIS TEST PASSES, DO NOT REPLACE THE INK SUPPLY STATION.

- 5 If the Printer does not detect all the out-of-ink signals then the Ink Supply Station must be faulty and the following message will appear on the Front Panel:

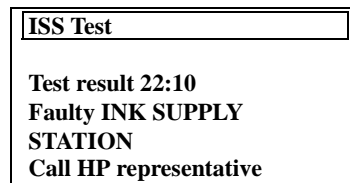

In this case, to resolve the problem, try the following:

- 1 *Replace the Ink Supply Station Assembly* ⇒ Page 8-48.

PHONE SUPPORT

Carriage Movement

The purpose of this test is to verify the movement of the scan-axis components at several speeds. This test checks for the following problems:

- Friction problems with worn out slider rod or Carriage Bushings.
- Blockage due to problems with the Service Station.
- Problems with encoder sensing.

NOTE

This Service Test can be performed by the End User with the guidance of a HP Support person via the phone.

WARNING

IF POSSIBLE ALWAYS PERFORM THIS TEST BEFORE REPLACING THE CARRIAGE ASSEMBLY. IF THIS TEST PASSES, DO NOT REPLACE THE CARRIAGE ASSEMBLY.

Perform the Carriage Movement test as follows:

- 1 In the Service Tests submenu, scroll to "Carriage movement" and press **Enter**.

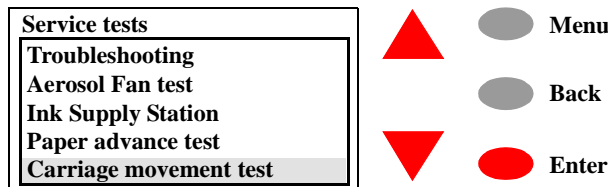

- 2 The test will start and the following message will appear on the Front Panel:

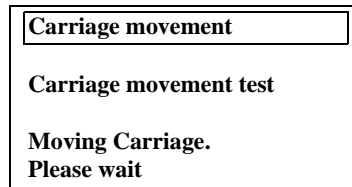

- 3 Once the Printer has completed the test it will analyze the data received while performing the test. Once the data has been analyzed, the following message will appear on the Front Panel:

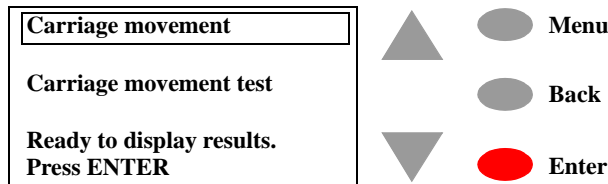

- 4 If you press **Enter**, the Front Panel will display a list of the different results you can view. You can make your selection using the arrow keys and press **Enter** to view the selection.

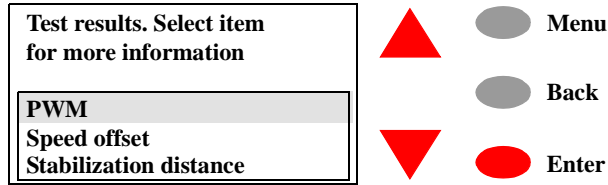

- 5 If you selected **PWM**, the Front Panel will display the results of the PWM test:

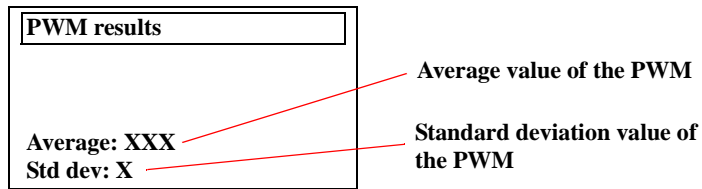

- 6 If you selected **Speed offset**, the Front Panel will display the results of the Speed offset:

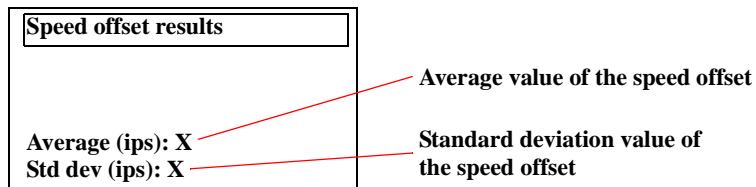

- 7 If you selected **Stabilization distance**, the Front Panel will display the results of the Stabilization distance:

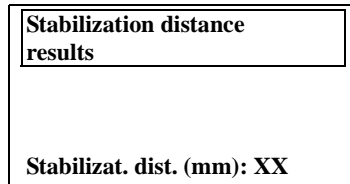

PHONE SUPPORT

Paper Advance Test

The purpose of this test is to identify whether there is too much friction in the paper-axis drive system which is caused by defects with the Transmission Gears, Drive Roller or the Paper-Axis Motor. This test should be performed when a Paper-Axis shutdown occurs which is not caused by a paper jam.

The Paper Advance test will perform the following tests:

- Paper-Axis Motor test.
- Drive Roller Encoder-Sensor test.
- Drive Roller test.

NOTE

This Service Test can be performed by the End User with the guidance of a HP Support person via the phone.

WARNING

IF POSSIBLE ALWAYS PERFORM THIS TEST BEFORE REPLACING PAPER-AXIS COMPONENTS. IF THIS TEST PASSES, DO NOT REPLACE ANY PAPER-AXIS COMPONENTS.

Perform the Paper Advance test as follows:

- 1 In the Service Tests submenu, scroll to "Paper Advance test" and press **Enter**.

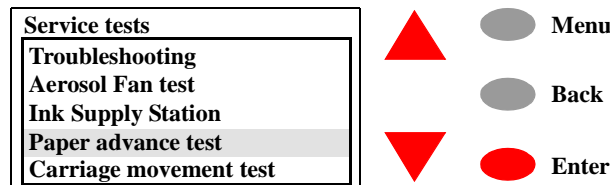

- 2 The test will first check if the Paper-Axis Motor is working by moving it slightly backwards and forwards. If this test passes, the following message will be displayed (press **Enter** to continue to the next stage of the test):

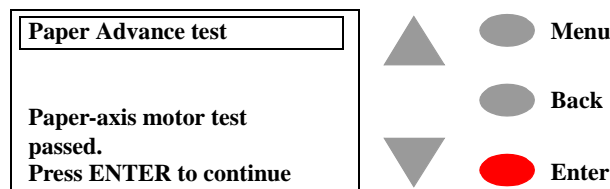

WARNING

IF THIS TEST PASSES, DO NOT REPLACE THE PAPER-AXIS MOTOR.

- 3 If the test fails while checking the Paper-Axis Motor, then the following message will be displayed:

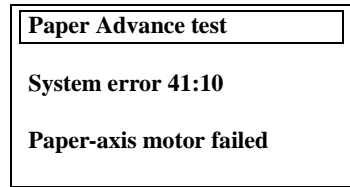

In this case, to resolve the problem, replace the Paper-Axis Motor ⇒ *Page 8-84*.

- 4 If the Paper-Axis Motor test passes, the Printer will try to read the Drive Roller Encoder-Sensor while moving the Paper-Axis Motor. If the Printer can read the signals from the Encoder-Sensor, then the test has passed and the following message will be displayed (press **Enter** to continue to the next stage of the test):

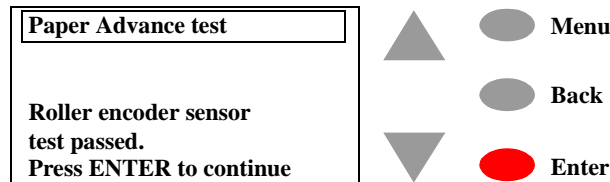

WARNING

IF THIS TEST PASSES, DO NOT REPLACE THE DRIVE ROLLER ENCODER-SENSOR.

- 5 If the Printer has problems reading the signal from the Drive Roller Encoder-Sensor, then the test has failed and the following message will be displayed:

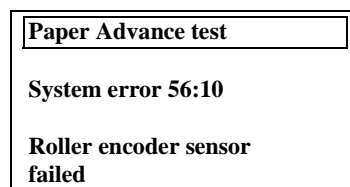

In this case, to resolve the problem, replace the Drive Roller Encoder Sensor ⇒ *Page 8-38*.

- 6 It is possible that while performing this test, a Paper-Axis shutdown occurs, in which case the following message will be displayed:

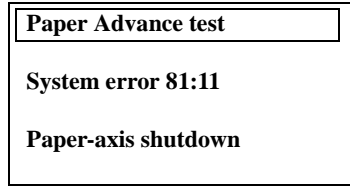

In this case, to resolve the problem, try the following:

- 1 *Open the Window and check for any visible obstacles that could be restricting the movement of the Drive Roller.*
- 2 *Try cleaning the Drive Roller using the Turn Drive Roller service utility ⇒ Page 4-21. Also try cleaning the Drive Roller Gears.*
- 3 *Replace the Drive Roller ⇒ Page 8-86.*
- 4 *Replace the Gear Assemblies ⇒ Page 8-92.*

WARNING

Only replace one component at a time and try the Service Test again before replacing another component. Using this procedure you will be able to determine exactly which component failed.

- 5 If the Drive Roller Encoder-Sensor test passes, the Printer will try turning the Drive Roller and the following message will appear on the Front Panel:

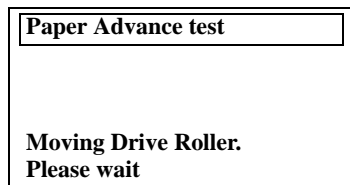

- 6 Once the test is completed, the results will be displayed on the front panel:

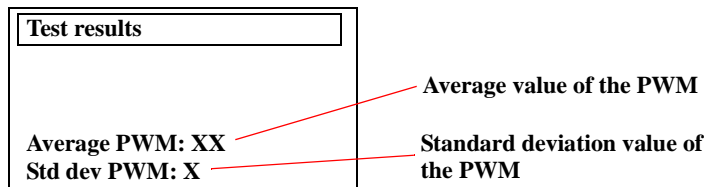

Service Utilities

The following is a list of all internal Service Utilities available in the Printers. Instructions for entering the Service Utilities menu are given on Page 4-14.

1 EEROM Setup ⇒ Page 4-16

The purpose of this Service Utility is to modify identification parameters such as serial and model numbers, as well as the Font Type. This only needs to be performed when EEROM failures cannot be recovered where both the current EEROM (located in the Main PCA) and the backup EEROM (located in the Ink Supply Station) contain false values or because both of them have failed.

2 Turn Drive Roller ⇒ Page 4-21

The purpose of this Service Utility is to rotate the Drive Roller in order to clean it.

3 Unlock Carriage ⇒ Page 4-22

The purpose of this Service Utility is to unlock the Carriage Assembly which is normally locked by the Service Station in order to cap the Printheads. Once unlocked, the Carriage Assembly can then be moved freely along the Printer by hand.

4 Prime Tubes ⇒ Page 4-23

The purpose of this Service Utility is to prime the Ink Supply Tubes after they have been replaced (or if a situation arises where you need to force the priming procedure).

5 Change Cutter ⇒ Page 4-24

The purpose of this Service Utility is to move the Cutter Assembly to a position where it can be replaced.

6 Change Ink Tubes ⇒ Page 4-25

The purpose of this Service Utility is to move the Carriage Assembly to a position where it makes the removal of the Ink Supply Tubes much easier.

7 Printer Information ⇒ Page 4-26

The purpose of this Utility is the following:

- Report basic parameters for call qualification.
- Identify potential problems.

Entering the Service Utilities Menu

- 1 Press the \uparrow or \downarrow key until the front panel displays the Setup Menu and then press **Enter**.

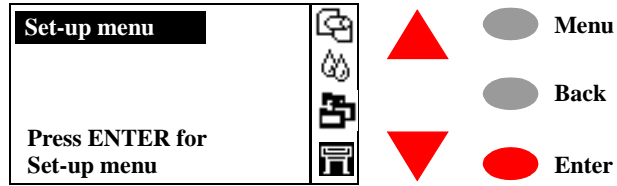

- 2 Once inside the Setup Menu, Press the following key combination to access the special Service Menu.

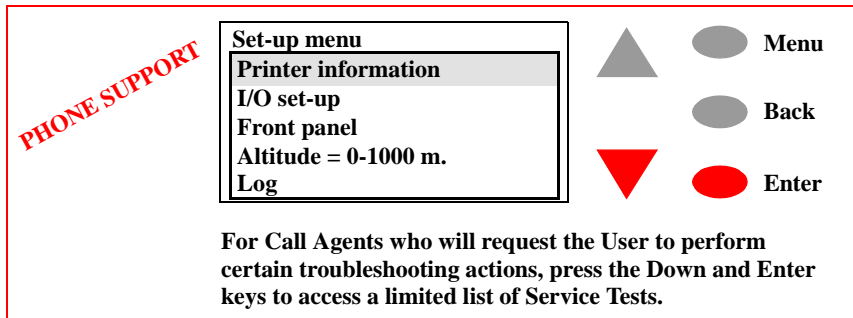
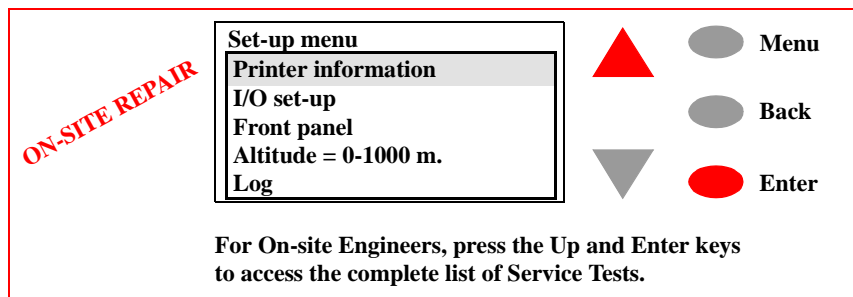

- 3 Once inside the Service Tools Menu, press the \uparrow or \downarrow key until the front panel displays **Service Utilities** and then press **Enter**.

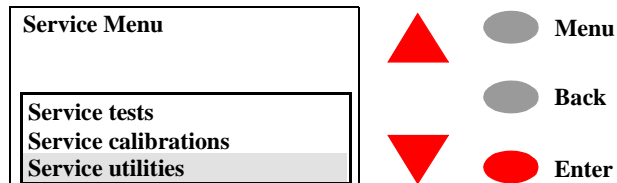

- 4 Press the **Enter** key to begin a specific utility when the required Service Utility is highlighted.

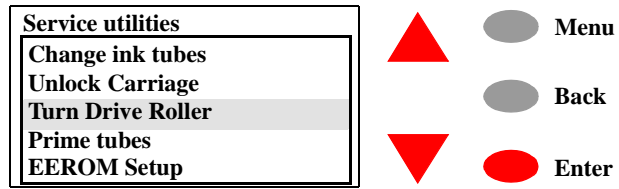

EEROM Setup

The purpose of this Service Utility is to modify identification parameters such as serial and model numbers, as well as the Font Type. This only needs to be performed when EEROM failures cannot be recovered where both the current EEROM (located in the Main PCA) and the backup EEROM (located in the Ink Supply Station) contain false values or because both of them have failed.

Also, you can use this utility to reset the usage counters for parts that have been replaced in order to correctly reflect the true usage of the relevant parts.

WARNING

After any change in the EEROM, switch the Printer OFF and ON again in order to ensure that the change takes effect in all the subsystems of the Printer.

Perform the EEROM Setup as follows:

- 1 In the Service Utilities submenu, scroll to "EEROM Setup" and press **Enter**.

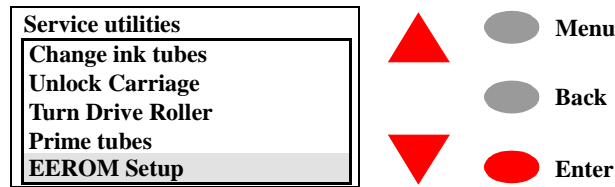

- 2 The Printer will display a list of EEROM Setup options. You can make your selection using the arrow keys and press **Enter** to view the selection.

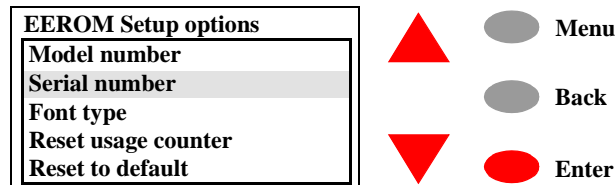

If you want to select the Model Number

- a If you want to select the Model number, then you should select "Model number" and press **Enter**. A list of all the printer model numbers available will appear on the front panel. The current model selected will have the symbol \surd next to the model number. Use the arrow keys to scroll through the selections, and press **Enter** to make the selection. Once the selection is made the

symbol \surd will appear next to the selected model number. To return to the EEROM setup options menu, press **Back**.

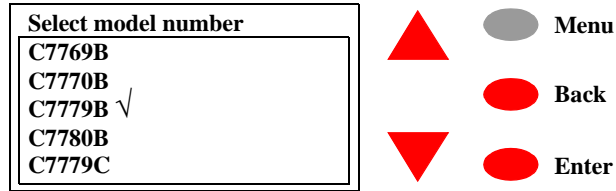

If you want to select the Serial Number

- a If you want to select the Serial number, then you should select "Serial number" and press **Enter**. The following information will be displayed on the front panel. You will need to use the arrow keys to scroll through the complete list because the front panel only allows 6 lines to be displayed at one time.

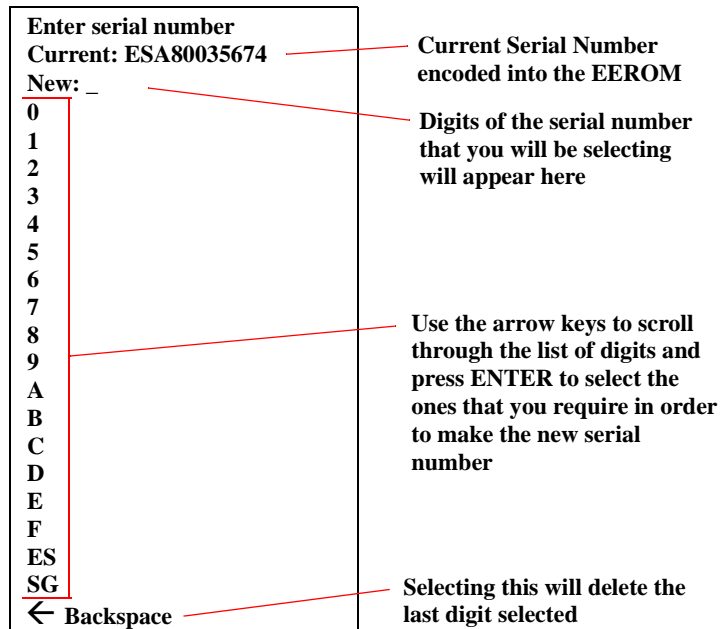

- b Use the arrow keys to scroll through the list of digits. Once the digit that you require is highlighted, press **Enter** to select it and it will appear in the **New** line.

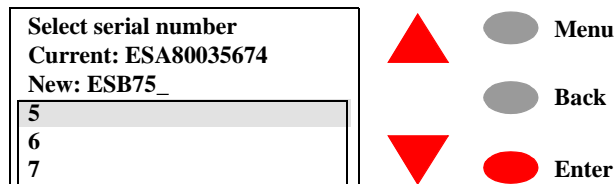

- c Once you have entered the last digit of the new serial number, the front panel will display the following message:

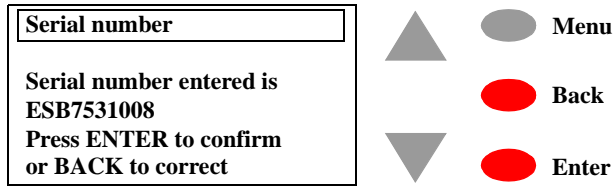

- d If you press **Enter**, the new serial number will be stored in the EEROM and the Printer will return to the EEROM setup options menu. If you press **Back**, the previous screen will be displayed and the last digit of the new serial number will be deleted. You now have the opportunity to modify the new serial number.

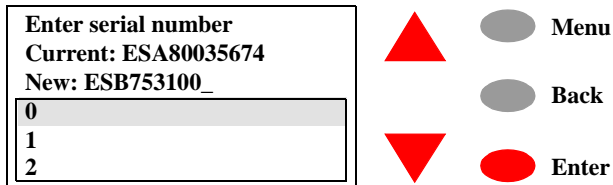

If you want to change the Font Type

- a If you want to change the Font Type to Japanese, then you should select "Font type" and press **Enter**. The following message will be displayed on the front panel asking you to confirm whether you want to change the font to Japanese. Select YES and press **Enter** if you want to change to Japanese. Select NO and press **Enter** if you don't want to change the font type to Japanese.

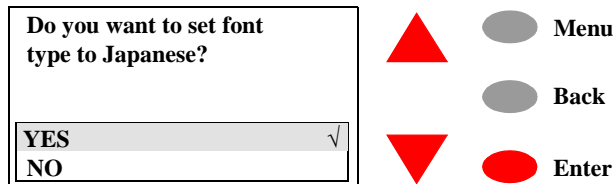

NOTE

If the Printer is not a DesignJet 800PS, or if the Printer does not detect a formatter, the Printer will not allow you to enter this utility and will display the following message on the front panel.

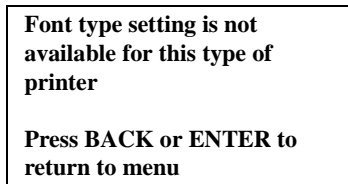

If you want to Reset the Usage Counter

NOTE

You should only reset the usage counter for a certain component when it has been replaced by a new one. Never reset the usage counter for a component when it has not been replaced.

- a If you want to reset some of the parameters of the usage counter (to consult the usage counters ⇒ Page 4-26), then you should select "Reset usage counter" and press **ENTER**. The following information will be displayed on the front panel. You will need to use the arrow keys to scroll through the complete list because the front panel only allows 6 lines to be displayed at one time. Select the usage counter that you want to reset and then press **Enter**.

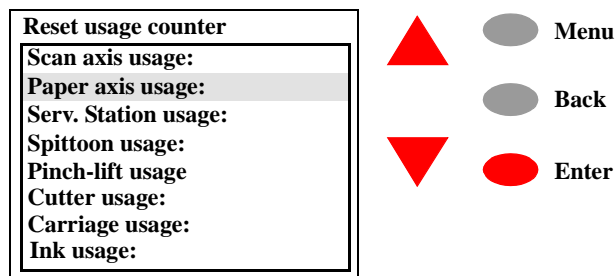

- b Once you make a selection (for example Scan axis usage), the following message will appear on the Front Panel. Press **Enter** if you want to proceed with resetting the counter or press **Cancel** if you want to exit without resetting the counter:

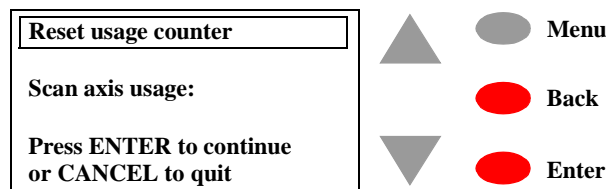

- c To check if the relevant usage counter has been reset, enter the Printer Information utility ⇒ Page 4-26.

If you want to Reset the EEROM to the Default Values

NOTE

The EEROM should only be reset if there is a major problem or if the Electronics Module has been replaced by a reused one and you need to reset the EEROM configuration. Also reset the EEROM if the Printer does not have the correct Serial Number after powering up.

- a If you want to reset the EEROM to the default values, then you should select "Reset to defaults" and press **Enter**. The following message will appear on the Front Panel. Press **Enter** if you want to proceed with resetting the EEROM or press **Cancel** if you want to exit without resetting the EEROM:

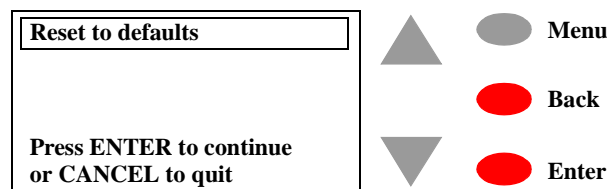

NOTE

After resetting the EEROM to the default values, you will need to re-enter the Serial Number, Model Number and the Font Type (without re-entering this information, the Printer will NOT work). **DO NOT SWITCH THE PRINTER OFF AND ON AGAIN BEFORE RE-ENTERING THESE VALUES.** Also you will need to perform the Factory Advance Calibration.

Turn Drive Roller

The purpose of this Service Utility is to rotate the Drive Roller in order to clean it.

NOTE

REMOVE THE MEDIA BEFORE PERFORMING THIS OPERATION.

Perform the Turn Drive Roller utility as follows:

- 1 In the Service Utilities submenu, scroll to "Turn Drive Roller" and press **Enter**.

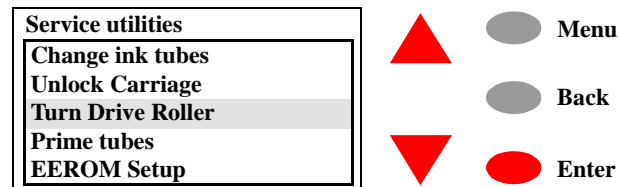

- 2 Once the utility starts, the Drive Roller will begin to turn slowly and the following message will be displayed. Everytime the Drive Roller completes a turn, the counter will increase by one.

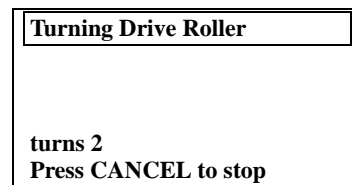

- 3 If you want to stop the Drive Roller from turning, press **Cancel** and the following message will appear on the front panel. Press **Enter** if you want to return to the Service Utility menu or press **Back** if you want to continue turning the Drive Roller.

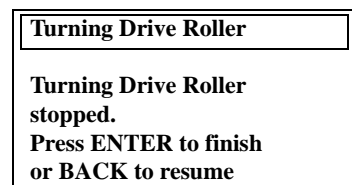

Unlock Carriage

The purpose of this Service Utility is to unlock the Carriage Assembly which is normally locked by the Service Station in order to cap the Printheads. Once unlocked, the Carriage Assembly can then be moved freely along the Printer by hand.

Perform the Unlock Carriage utility as follows:

- 1 In the Service Utilities submenu, scroll to "Unlock Carriage" and press **Enter**.

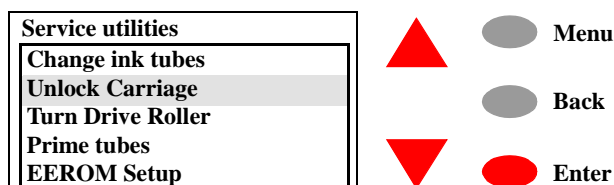

- 2 Once the utility starts, the printer will begin to unlock the Carriage Assembly and the following message will be displayed on the front panel.

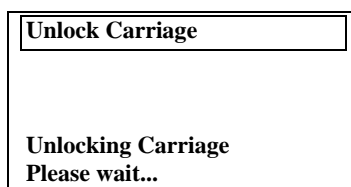

- 3 Once the Carriage is unlocked (Printheads have been uncapped) the following message will appear on the front panel:

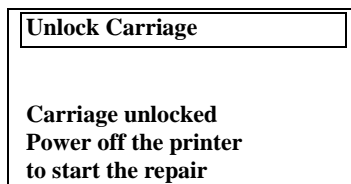

NOTE

The Carriage will remain uncapped until another action (e.g. loading paper or replacing Printheads) is selected which returns the Printer to normal operation. Make sure you leave the Carriage in a locked position once the repair is completed.

Prime Tubes

This purpose of this Service Utility is to prime the Ink Supply Tubes after they have been replaced (or if a situation arises where you need to force the priming procedure).

Prime the tubes as follows:

- 1 In the Service Utilities submenu, scroll to "Prime tubes" and press **Enter**.

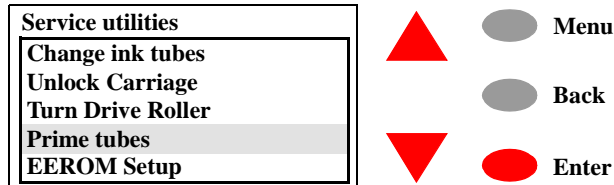

- 2 Once the utility starts, the printer will display the following message on the front panel. If you want to abort the Prime Tubes utility, press **Cancel** and you will return to the Service Utility menu.

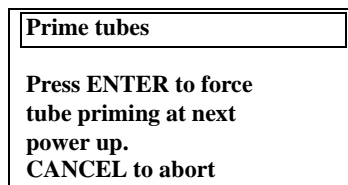

- 3 If you press **Enter**, the following message will be displayed on the Front Panel. You should switch the Printer ON and OFF in order to start the priming process.

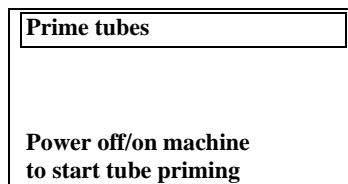

- 4 When you power On the Printer, the Printer will initialize and then display the following message. You will need to remove the normal Printheads and replace them with Start-up Printheads.

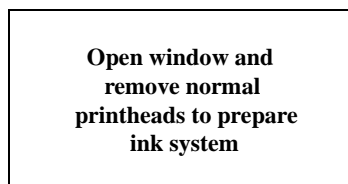

Change Cutter

The purpose of this Service Utility is to move the Cutter Assembly to a position where it can be replaced.

NOTE

In order to actually replace the Cutter Assembly, refer to Page 8-32.

Perform the Change Cutter utility as follows:

- 1 In the Service Utilities submenu, scroll to "Change cutter" and press **Enter**.

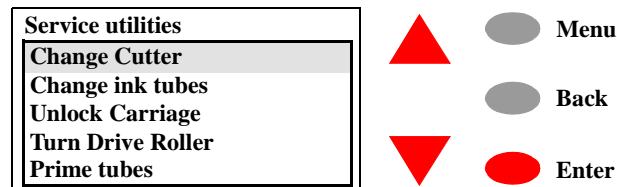

- 2 The Carriage will move to the left hand side of the Printer, pick up the Cutter and move it to a position where the Cutter can be replaced.

Change Ink Tubes

The purpose of this Service Utility is to move the Carriage Assembly to a position where it makes the removal of the Ink Supply Tubes much easier.

NOTE

In order to actually replace the Ink Supply Tubes, refer to Page 8-60.

Perform the Change Ink Tubes utility as follows:

- 1 In the Service Utilities submenu, scroll to "Change Ink Tubes" and press **Enter**.

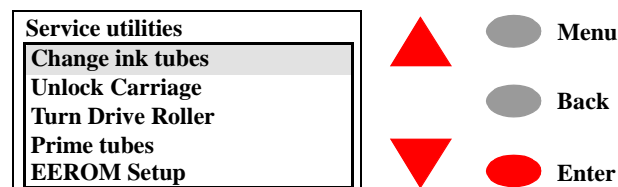

- 2 Once the utility starts, the printer will display the following message on the front panel. If you want to abort the Change Ink Tubes utility, press **Cancel** and you will return to the Set-up menu.

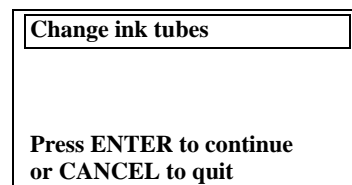

- 3 If you press **Enter**, the Carriage will move to a position where you change the Ink Supply Tubes and the following message will be displayed on the Front Panel. You should switch the Printer OFF before starting to change the Ink Supply Tubes.

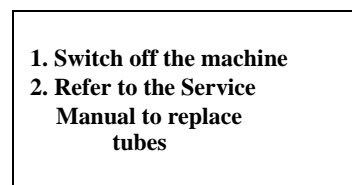

NOTE

The next time the Printer is switched ON, it will automatically start the Priming process.

Printer Information

The purpose of this Utility is the following:

- Report basic parameters for call qualification.
- Identify potential problems.

NOTE

Some of the parameters can be reset to zero by using the EEROM Setup utility (⇒ Page 4-16).

Check the Printer Information as follows:

- 1 In the Service Utilities submenu, scroll to "Printer Information" and press **Enter**.

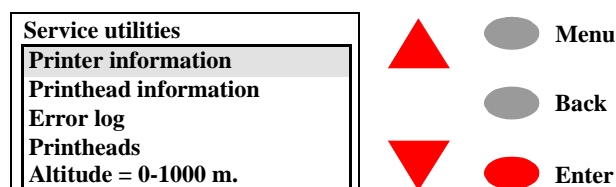

- 2 The Printer will display the following information on the front panel. You will need to use the arrow keys to scroll through the complete list because the front panel only allows 6 lines to be displayed at one time.

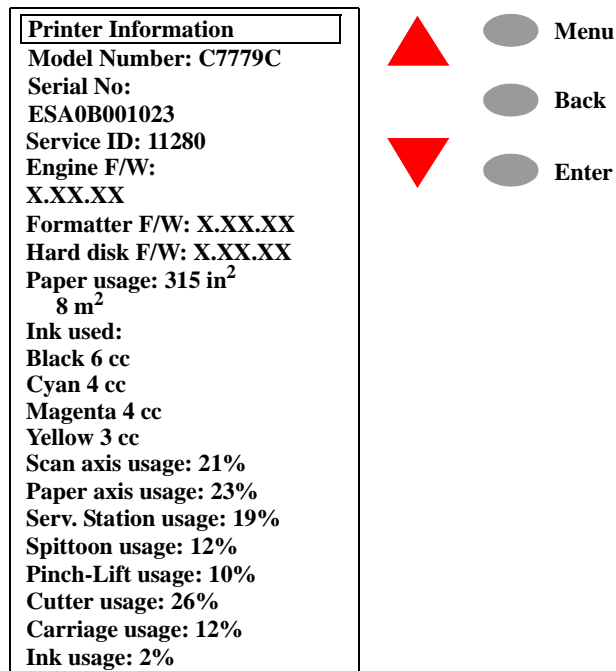

Each parameter of the Printer Information is explained as follows:

- **Model Number** - This identifies the model type of the Printer and should be the same number as printed on the Serial Number label (located at the back of the Printer). If the Model Number on the front panel does NOT match the number on the label, then use the EEROM setup (\Rightarrow Page 4-16) utility to set the correct model number.
- **Serial Number** - The Serial Number should be the same number as printed on the Serial Number label (located at the back of the Printer). If the Model Number on the front panel does NOT match the number on the label, then use the EEROM setup utility (\Rightarrow Page 4-16) to set the correct model number.
- **Service ID** - This number identifies the date when the Printer was bought since it encodes the date when the first print was sent to the Printer. This way the end of warranty period can easily be determined without needing a proof of purchase from the customer. The Service ID format is **YYDDD**, where **YY** is the actual year since 1990 and **DDD** is the number of actual days since January 1st.

How to calculate the Service ID from a calendar date:

YY = calendar year - 1990 (e.g.: 1998 = (1998 - 1990) = **08**; 2001 = (2001 - 1990) = **11**)

DDD = (Calendar month - 1) x 30 + Calendar day or 30 if the day is 31 (e.g.: Oct. 10th = (9 x 30 + 10) = **280**; Dec. 31st = (11 x 30 + 30) = **360**)

How to convert the Service ID into a calendar date:

Year = **YY** + 1990 (e.g.: **08** = (08 + 1990) = 1998; **11** = (11 + 1990) = 2001)

Date = **DDD** divided by 30, plus one if there is a remainder, gives you the month. The remainder gives you the day of the month (e.g. **280** (280/30 = 9 + 1 = 10) = October 10th; **360** = (360/30 = 12) = December 30th)

- **Engine F/W** - The current version of the Firmware being used by the Printer and the date that it was updated.
- **Formatter F/W** - The current version of the Firmware being used by the Formatter (if it is installed).
- **Hard disk F/W** - The current version of the Firmware being used by the Hard Disk (only if the Formatter is installed).
- **Paper usage** - The amount of media used by the Printer.
- **Ink usage** - The amount of Ink used by the Printer.
- **Scan axis usage** - Number of Scan-Axis cycles represented as a percentage over the maximum number of Scan-Axis cycles that the

Printer is designed to support. If the percentage is **more than** 100% and the Printer is experiencing problems then try the following:

- 1 Apply Lubricant to the Drive Roller.
- 2 Replace the Carriage Assembly (including the Belt) ⇒ Page 8-78.
- 3 Replace the Scan-Axis Motor ⇒ Page 8-29.

- **Paper axis usage** - Number of Paper-Axis movements represented as a percentage over the maximum number of Paper-Axis movements that the Printer is designed to support. If the percentage is **more than** 100% and the Printer is experiencing problems then try the following:

- 1 Replace the Paper-Axis Motor ⇒ Page 8-84.

- **Service Station usage** - Number of Service Station cycles represented as a percentage over the maximum number of Service Station cycles that the Printer is designed to support. If the percentage is **more than** 100% and the Printer is experiencing problems then try the following:

- 1 Replace the Service Station ⇒ Page 8-52.

- **Spittoon usage** - Number of drops spitted into the Spittoon (on the left hand side of the Printer) represented as a percentage over the maximum number of drops allowed by the Spittoon. If the percentage is **more than** 100% and the Printer is experiencing problems then try the following:

- 1 Replace the Spittoon ⇒ Page 8-23.

- **Pinch-lift usage** - Number of Pinch-lift cycles represented as a percentage over the maximum number of cycles that the Printer is designed to support. If the percentage is **more than** 100% and the Printer is experiencing problems then try the following:

- 1 Replace the Pinch-Lift Mechanism ⇒ Page 8-67.

- **Cutter usage** - Number of times the Cutter has been used represented as a percentage over the maximum number of times that the Printer is designed to support. If the percentage is **more than** 100% and the Printer is experiencing problems then try the following:

- 1 Replace the Cutter Assembly ⇒ Page 8-32.

- **Carriage usage** - Number of Printhead insertions in the Carriage stall where the most Printheads have been inserted represented as a percentage over the maximum number of Printhead insertions that the Printer is designed to support. If the percentage is **more than** 100% and the Printer is experiencing problems then try the following:

- 1 Replace the Carriage Assembly ⇒ Page 8-78.

Service Calibrations

5

Service Calibrations	5-2
Entering the Service Calibrations Menu	5-3
Printhead Alignment (includes PPS Calibration)	5-5
Color Calibration	5-7
Advance Calibration	5-9
Factory Advance Calibration	5-11

Service Calibrations

The following is a list of all internal service calibrations available in the Printers. Instructions for entering the service calibrations menu are given on Page 5-3.

1 Printhead Alignment ⇒ Page 5-5

The purpose of this Service Calibration is to correct the alignment between the Printheads. This calibration is necessary in order to prevent color misalignment and print quality defects like banding.

2 Color Calibration ⇒ Page 5-7

The purpose of this Calibration is to calibrate the ink system for the specific media loaded into the Printer. The Printer stores the calibration data for each type of media that has been calibrated since the Printer was switched ON. If the Printer is switched OFF, it will only store the last calibration done.

3 Advance Calibration ⇒ Page 5-9

The purpose of this Service Calibration is to calibrate the nominal advance of the media. This calibration is necessary to control the exact movement on the media type that will be used (upto 2) in order to avoid print quality problems like banding.

4 Factory Advance Calibration ⇒ Page 5-11

The purpose of this Service Calibration is to calibrate the nominal advance of the media. This calibration is necessary to control the exact movement of the media in order to avoid print quality problems like banding. The values from the Calibration will then be stored in the EEROM and the user can restore the Printer to these values by selecting "Restore factory" in the Advance Calibration menu.

Entering the Service Calibrations Menu

- 1 Press the \uparrow or \downarrow key until the front panel displays the Set-up Menu and then press **Enter**.

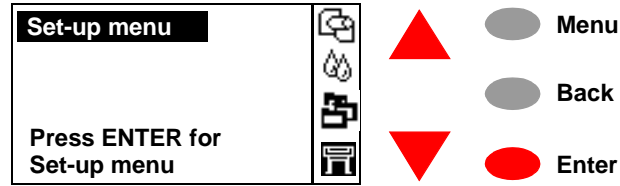

- 2 Once inside the Setup Menu, Press the following key combination to access the special Service Menu.

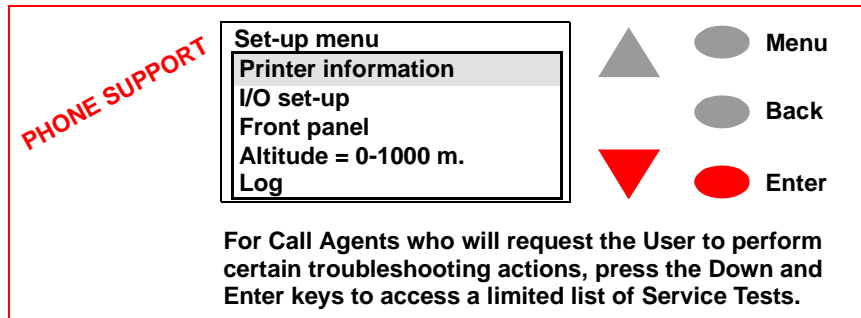
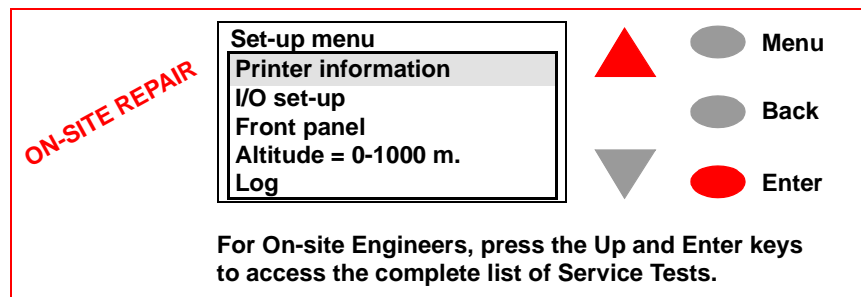

- 3 Once inside the Service Tools Menu, press the \uparrow or \downarrow key until the front panel displays **Service calibrations** and then press **Enter**.

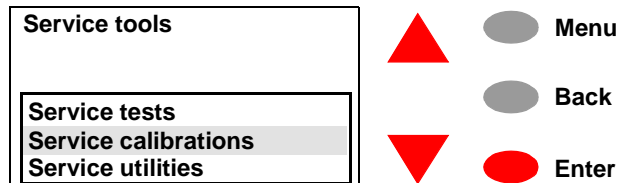

- 4 Press the **Enter** key to begin a specific calibration when the required Service Calibration is highlighted.

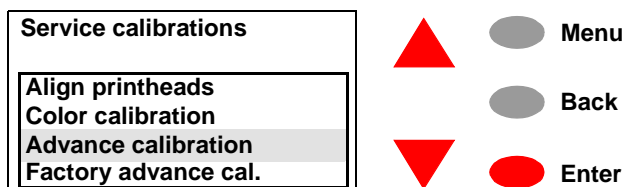

Printhead Alignment (includes PPS Calibration)

The purpose of the Printhead Alignment is to correct the alignment between the Printheads in order to prevent color misalignment and print quality defects like banding. Normally the Printhead Alignment is performed automatically whenever the printheads are replaced.

The Printhead Alignment also contains the Pen to Paper Spacing (PPS) Calibration which is used to solve Vertical Line Straightness (VLS) problems. During normal operation, the PPS calibration **will not** be performed automatically whenever the Printheads are replaced, even though the Printhead Alignment will be performed automatically.

There are two options available when performing the Printhead Alignment:

- Standard - Use this when **only** the Printheads need to be aligned. This Alignment normally takes about 4½ minutes to be completed and requires media of at least **A4/Letter**-size (loaded in landscape).
- Special - Use this when VLS problems have been detected when printing line drawings on wide media (36" to 42") in Fast Mode. Using this option the Printer will perform both the regular Printhead Alignment and the PPS Calibration. This Alignment normally takes about 11 minutes and requires media of at least **A3/B**-size (loaded in landscape).

Perform the Printhead Alignment as follows:

WARNING

Make sure you use HP Bright White InkJet Paper (Bond), HP Coated Paper, HP Heavy Coated Paper, HP High-Gloss Paper, HP Satin Paper or Plain Paper. If you try to use any other type of Paper the Printer will not allow you to perform the Alignment.

- 1 In the Service Calibrations submenu, scroll to "Align printheads" and press **Enter**.

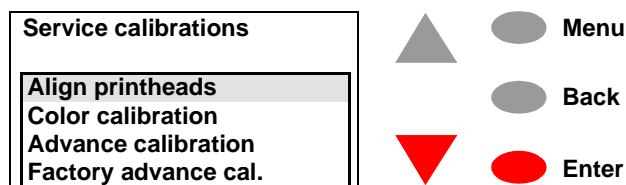

- 2 The following message will appear asking you if you want to perform the **Standard** alignment or the **Special** alignment. Select

the alignment you want to perform and then press **Enter**.

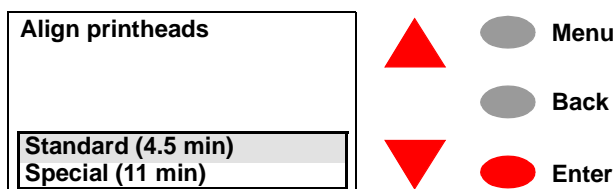

- 3 The Printer will start to print the alignment pattern and the following message will be displayed on the front panel:

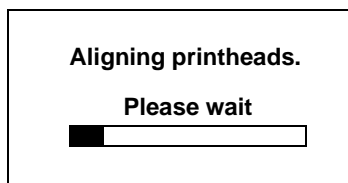

- 4 Once the Printhead Alignment is completed, the following message will be displayed on the front panel:

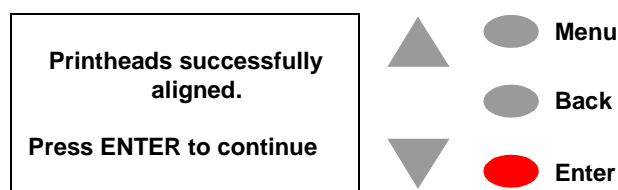

- 5 If the calibration fails due to poor Print Quality it will try and recover the Printheads and retry the Printhead Alignment. *If the Calibration continues to fail due to Printhead problems, the Printer will mark the failing Printheads (but they will still be usable).*

Color Calibration

The purpose of this Calibration is to calibrate the ink system for the specific media loaded into the Printer. The Printer stores the calibration data for each type of media that has been calibrated since the Printer was switched ON. If the Printer is switched OFF, it will only store the last calibration done.

Perform the Color Calibration as follows:

NOTE

Make sure you load media before performing this calibration.

- 1 In the Service Calibrations submenu, scroll to "Color calibration" and press **Enter**.

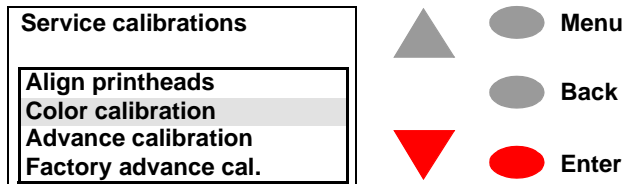

- 1 In the Color Calibration submenu, scroll to "Calibrate paper" and press **Enter**.

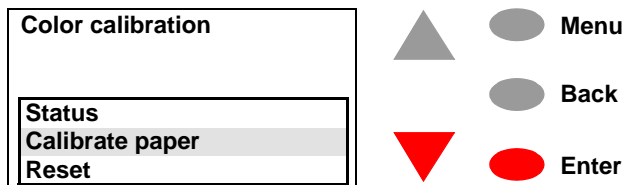

- 2 The Printer will start to print the calibration pattern and the following message will be displayed on the front panel:

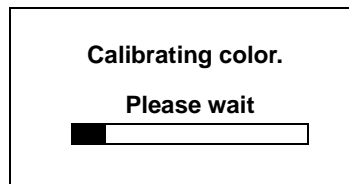

- 3 Once the Color Calibration is completed, the following message will be displayed on the front panel:

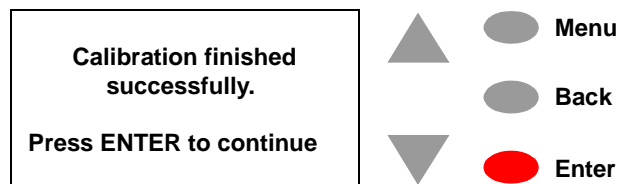

If the calibration fails, then the following message will appear on the front panel:

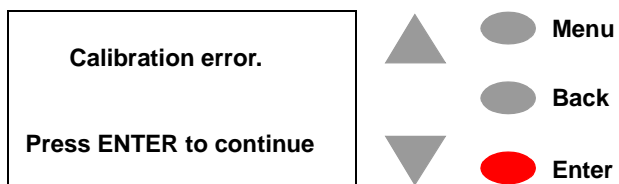

In this case, to resolve the problem, try the following:

- Make sure that you DO NOT use transparent media when performing the Color Calibration.
- Clean the Line Sensor and try the Calibration again.
- Make sure that the Window is closed when you perform the Color Calibration.

Advance Calibration

The purpose of this Service Calibration is to calibrate the nominal advance of the media. This calibration is necessary to control the exact movement on the media type that will be used (upto 2) in order to avoid print quality problems like banding.

Perform the Advance Calibration whenever:

- Banding is detected in prints.
- Printheads Diagnostic is OK.

Perform the Advance Calibration as follows:

- 1 In the Service Calibrations submenu, scroll to "Advance calibration" and press **Enter**.

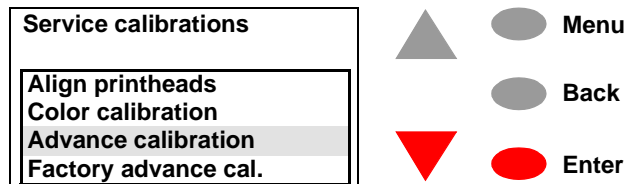

- 2 When the following message appears on the front panel, select "Create pattern" and press **Enter**.

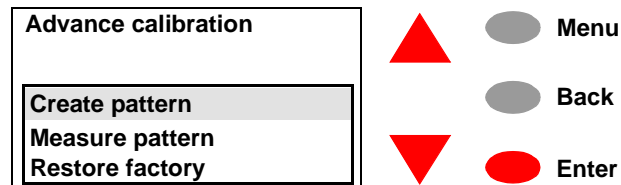

- 3 If media is not loaded, the following message appears on the front panel and you must load media into the Printer.

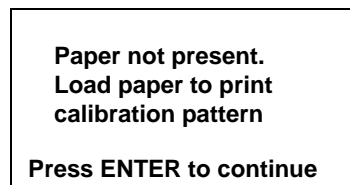

- 4 The Printer will start to print the Accuracy Calibration Pattern and the following message will be displayed on the front panel:

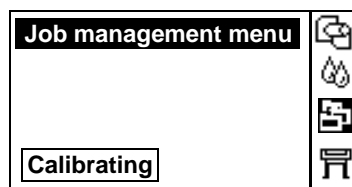

- 5 The following drawing shows you the pattern that will be printed:

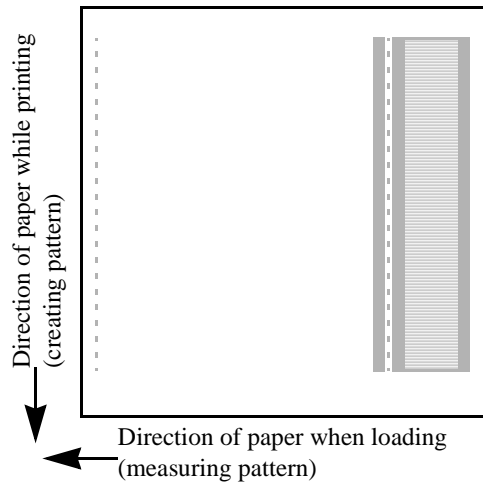

- 6 In order to measure the pattern that has been printed, load the pattern into the Printer with the printed side up and with the dotted line at the top (that is, rotated 90°).
- 7 Re-enter the Advance Calibration and select "Measure pattern" and press **Enter**.

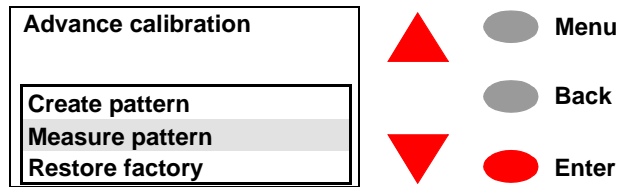

- 8 The Printer will measure the alignment marks using the line sensor on the Carriage Assembly. The following message will be displayed while the Printer measures the pattern:

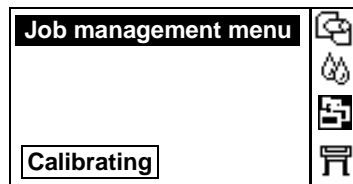

- 9 Once the calibration is completed, the following message will be displayed:

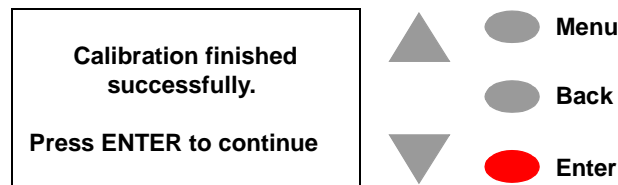

Factory Advance Calibration

The purpose of this Service Calibration is to calibrate the nominal advance of the media. This calibration is necessary to control the exact movement of the media in order to avoid print quality problems like banding. The values from the Calibration will then be stored in the EEROM and the user can restore the Printer to these values by selecting "Restore factory" in the Advance Calibration menu.

Perform the Factory Advance Calibration whenever:

- Banding is detected in prints for **all** HP Media standard paper types and Printheads Diagnostic is OK.
- Drive Roller is disassembled or replaced.
- Paper-Axis Motor Assembly is disassembled or replaced.
- Electronics Module AND the Ink Supply Station are replaced.

Perform the Factory Advance Calibration as follows:

NOTE

Make sure you load HP High Gloss Photo Paper or HP Bright White Inkjet Paper in to the Printer before performing this calibration. Do NOT use any other type of media apart from HP High Gloss Photo Paper or HP Bright White Inkjet Paper otherwise the Printer will display "Calibration Error" on the Front Panel and the calibration will be cancelled.

- 1 In the Service Calibrations submenu, scroll to "Factory advance cal." and press **Enter**.

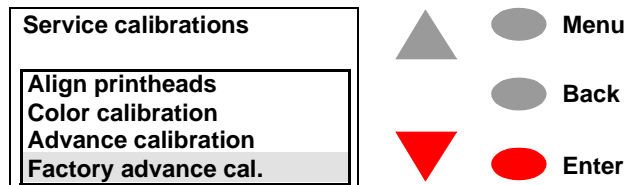

- 2 When the following message appears on the front panel, select "Create pattern" and press **Enter**.

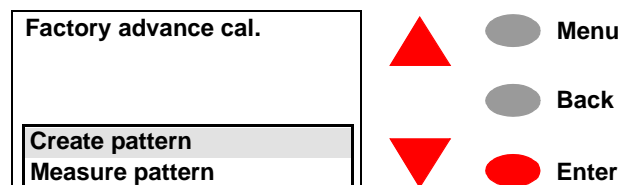

- 3 If media is not loaded, the following message appears on the front panel and you must load media into the Printer.

NOTE

Do NOT use any other type of media apart from HP High Gloss Photo Paper or HP Bright White Inkjet Paper.

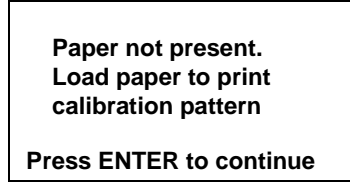

- 4 The Printer will start to print the Accuracy Calibration Pattern and the following message will be displayed on the front panel:

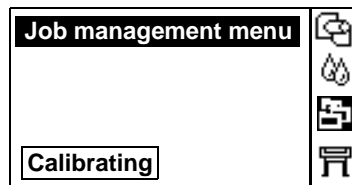

- 5 The following drawing shows you the pattern that will be printed:

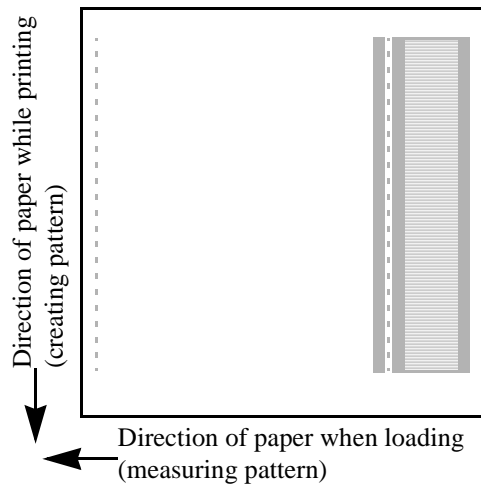

- 6 In order to measure the pattern that has been printed, load the pattern into the Printer with the printed side up and with the dotted line at the top (that is, rotated 90°).

- 7 Re-enter the Advance Calibration and select "Measure pattern" and press **Enter**.

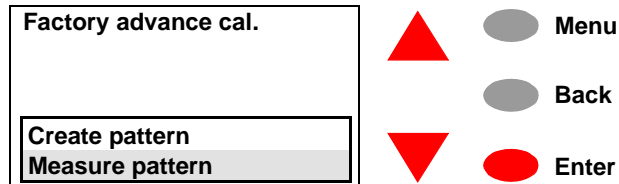

- 8 The Printer will measure the alignment marks using the line sensor on the Carriage Assembly. The following message will be displayed while the Printer measures the pattern:

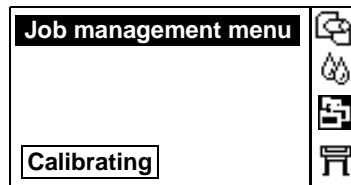

- 9 Once the calibration is completed, the following message will be displayed:

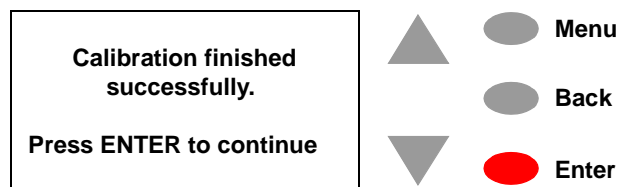

Print Quality

6

Print Quality	6-2
Print Quality Troubleshooting Checklist	6-2
How to Use the Troubleshooting Procedure	6-4
What is the Troubleshooting Procedure?	6-4
Performing the Troubleshooting Procedure	6-4
Troubleshooting Procedure Flowchart	6-7
No Printing Defects Found Using the Troubleshooting Procedure	6-8
Long Term Color Bleeding (Glossy Papers)	6-9
Solving Color Accuracy problems	6-9
Color Consistency problems	6-9
Media	6-10
There are Smears or Scratching on the Printed Media	6-10

Print Quality

Print Quality Troubleshooting Checklist

When faced with a Print Quality problem, use the following checklist as a guide in troubleshooting the problem:

- 1 Problem reproduction
 - Reproduce the problem that the customer is seeing using their original settings.
- 2 Printer configuration
 - Print Mode: Set to **Best** (in the driver).
 - Dry time: Set to **Automatic**.
 - Select the correct media setting when loading the media.
- 3 Hardware check list
 - Firmware Revision
 - Check if the latest version of the firmware is installed. If not update the Printer with the latest firmware revision.
- 4 Printheads
 - Printhead Troubleshooting Process
 - If you don't have any samples yet, reproduce the original problem with the correct printer settings.
 - Perform the **Troubleshooting** procedure using the exact settings and Media that the Customer used when faced with the Print Quality problem.
 - Printhead Alignment and Check
 - Perform the Printhead Alignment using HP High-Gloss Photo Paper. If not available, use Coated media if required.
- 5 Media
 - Make sure that you use HP or HP-approved media.
 - Select the correct media type through the front-panel when loading it.
- 6 Driver print quality configuration:
 - To clarify if the reason of the problem is related with the print mode defined with the Non-HP Driver try the following:
 - Print the same sample using the Non-HP driver and their normal media.
 - Print one of the internal demos using HP Media and configuring

the Printer as indicated previously.

- If the output obtained using the HP Solution is good and the one obtained through the 3rd party solution is bad, HP support organization should communicate to the customer that the problem is not in the Printer and that he should address it through the 3rd party vendor support structure.

7 Service Accuracy Calibration

- Perform "Service Accuracy calibration" using HP High-Gloss Photo Paper.

WARNING

Do NOT use any other type of media apart from HP High Gloss Photo Paper or Bright White InkJet Paper when performing the Accuracy Calibration.

How to Use the Troubleshooting Procedure

What is the Troubleshooting Procedure?

The Printer contains an internal **Troubleshooting** procedure which helps you to diagnose and resolve the possible source of any Image Quality or Line Quality defects. If Print Quality is poor **at anytime**, the **Troubleshooting** procedure should be performed which will determine whether the Printhead needs replacing (by marking it with an exclamation mark) or not after performing various levels of recovery actions.

Considerations for Using the Troubleshooting Procedure.

- 1 It is important that the media that you use for the **Troubleshooting** procedure is exactly the same as the one that the customer used when they experienced the print quality problem. If the customer used HP Glossy Paper size A0, then you must use HP Glossy Paper size A0. If you use a different type of media or a different size, then there is a possibility that the print quality problem will not be resolved.
- 2 If the customer is using non-HP media and after the **Troubleshooting** procedure you still have the same print quality problems, change to genuine HP media and repeat the **Troubleshooting** procedure. Using this process you can determine if the problem is with the Printer or with the non-HP media.
- 3 If you do not see any problems with the **Troubleshooting** procedure but still experience print quality problems, then the problem may not be with the Printer itself. The problem may be with the RIP or the driver for example.

Performing the Troubleshooting Procedure

- 1 To perform the **Troubleshooting** procedure press the ↑ or ↓ key until the front panel displays the **Ink Menu** and then press **Enter**.

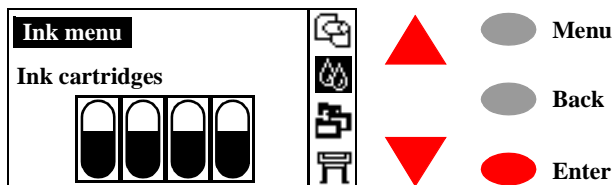

- 2 Press the \uparrow or \downarrow key until the front panel highlights **Troubleshooting** and then press the **Enter** key.

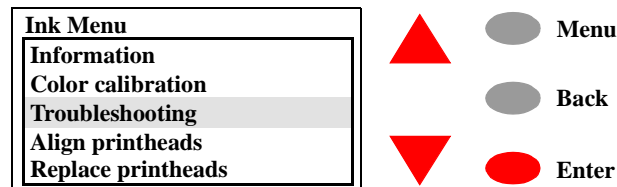

- 3 The Printer first checks to see whether the Printheads have been aligned recently. Misalignment of the Printheads is a common cause of Print Quality problems, so if the Printheads haven't been aligned recently, you are prompted to accept the alignment now.

NOTE

The Printhead Alignment requires a few centimeters of Paper loaded and takes several minutes to perform.

- 4 If the Printheads do not seem to require alignment, the Printer prints the **Diagnostic Print A**, which contains several blocks of color and a block of thin black broken lines.

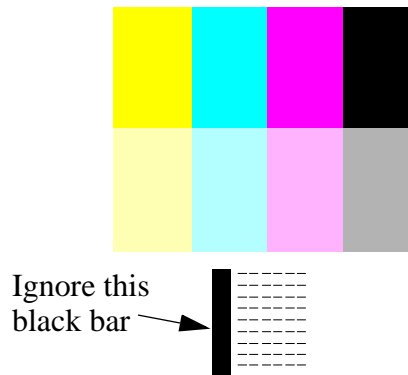

- 5 Examine the broken lines carefully and when prompted by the front panel, indicate whether there are problems with them. The sorts of problems to look for are:
- Jaggedness or serrations in the thin lines, like this:

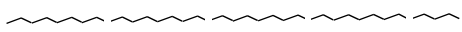

 The lines should be straight, though not necessarily perfectly aligned. The irregularities that are significant extend along the whole of the length of the lines. Shorter irregularities, arranged in columns, can be ignored at this stage.
- 6 If you indicate that there is a problem with the dashed lines, you are prompted to perform the **Advance Calibration** procedure.
- 7 If you indicate that the broken lines in **Diagnostic Print A** are OK, then examine the blocks of color carefully and when prompted by

the front panel, indicate whether there are problems with them. The sorts of problems to look for are:

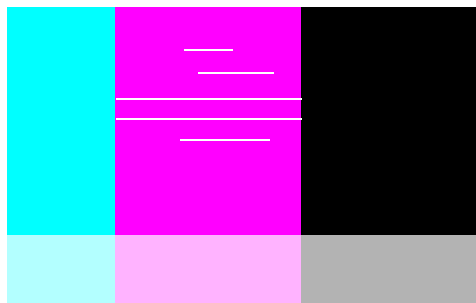
- White streaks or bands in the solid blocks.

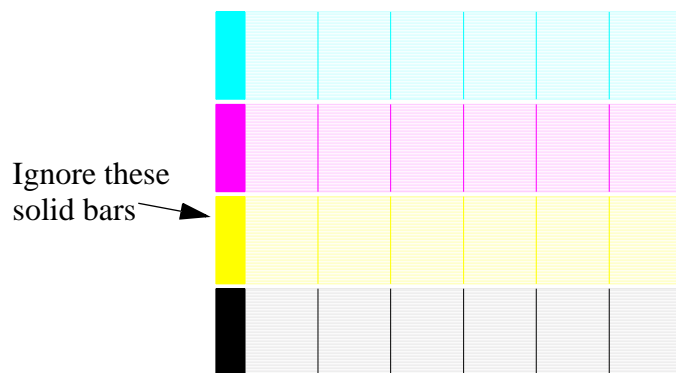

- 8 If you indicate that there are problems in the blocks of color, the Printer will try and clean the Printheads that have the problem. A Printhead can be cleaned up to 3 times in this way after which it will need to be replaced (you will be informed via the front panel).
- 9 After cleaning the Printheads, the Printer reprints the **Diagnostic Print A**, and you need to repeat the previous steps.
- 10 If you indicate that the blocks of color in **Diagnostic Print A** are OK, the Printer will print **Diagnostic Print B**.



- 11 For each color in the pattern in **Diagnostic Print B**, you are asked about the quality - look especially for missing lines. If you indicate that a color is defective, the Printer tries to clean that printhead.
- 12 After cleaning the Printheads, the Printer reprints the **Diagnostic Print B**, and you need to repeat the previous steps.
- 13 If none of the patterns or blocks in the 2 **Diagnostic Prints** show any problems, it could be that the Print Quality problem is caused by a wrong setting in the software, or maybe the print job should have been printed with **Print Quality** set to **Best** instead of **Normal** or **Draft**.

Troubleshooting Procedure Flowchart

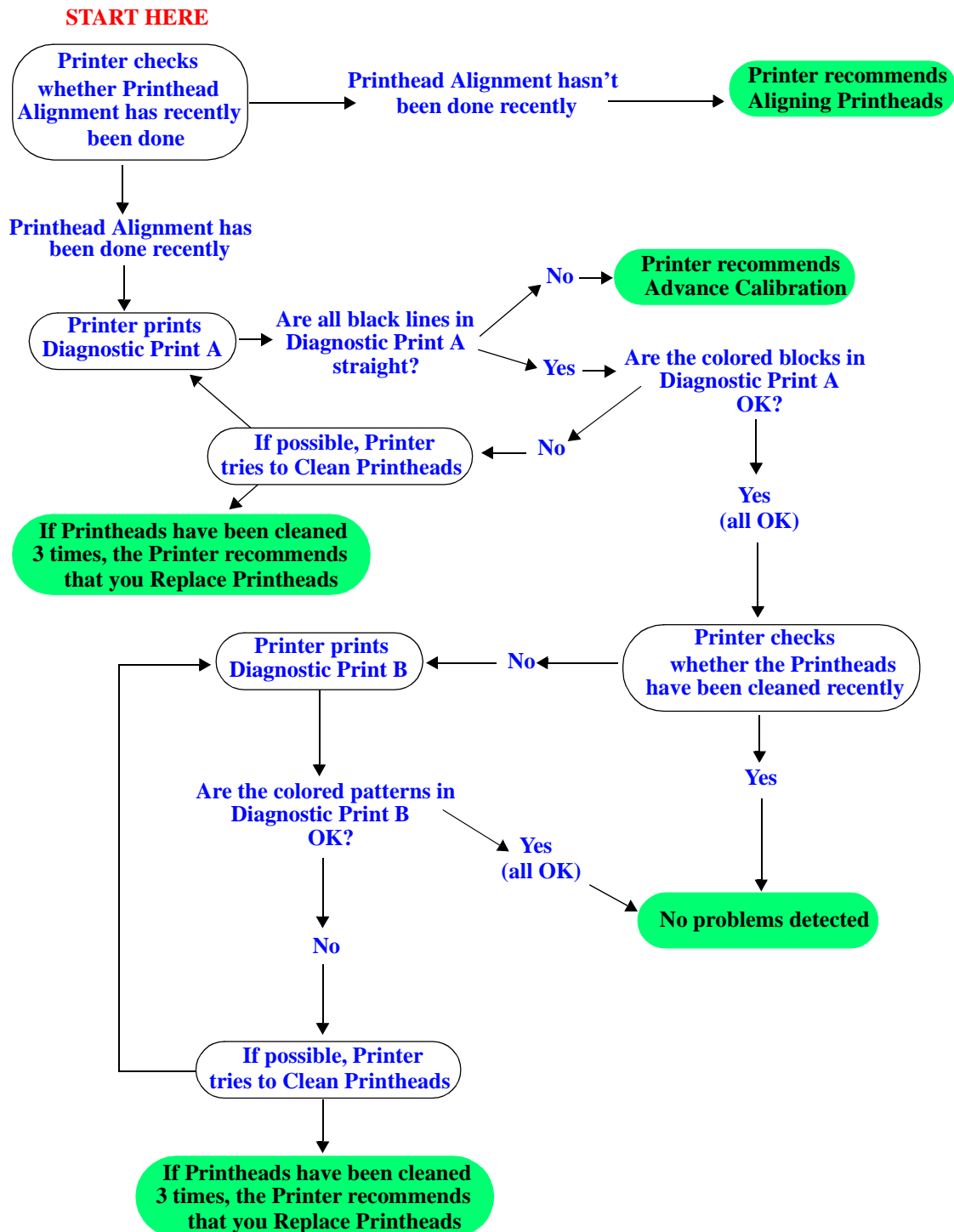

No Printing Defects Found Using the Troubleshooting Procedure

If all the test patterns from the **Troubleshooting** procedure are correct and you still experience print quality problems, here are some of the more likely causes to check:

- The print mode used in the Printer is not right for the image that is being printed (this is defined by the printer’s front-panel menu selections).
- Non-HP driver.
- The RIP (if it is being used).
- The software application the client is using.

Use the following table to configure the system correctly.

What to Configure	Configuration Setting	Optimal Setting
Printer Front-Panel Menu	Media	Make sure you have selected the correct media type in the front panel.
	Dry time	Set to Automatic.
HP driver (Windows, AutoCAD or Mac)	Print mode setting	Set to Best.
Non-HP drivers (Software RIPs)	The settings available depend on the driver. The most typical settings are: <ul style="list-style-type: none"> ■ Print Quality Settings ■ Half Tone ■ Media selection See the user’s guide for your application for more information about its print quality settings.	In the software application: <ul style="list-style-type: none"> ■ Set Print Quality to Best ■ Use no Half Tone (or printer default.) ■ Make sure that the media setting matches the media loaded in the printer.

Solving Color Accuracy problems

These are two areas you should review when troubleshooting a color accuracy problem:

Configuration (PostScript option only)

Check that you are using the correct driver setting and CRD information for the software. Check which ink emulation mode has been selected in the front panel.

Media

Make sure that the media loaded is genuine HP media and that the correct media type has been selected on the front panel and in the driver.

Color Consistency problems

- If color consistency is important for the customer, it is recommended that they do not use HP-GL/2 to print with.
- Some media may discolor or change with age. Check that the media is fresh and has been stored correctly.
- If the environmental conditions that the customer is printing in change rapidly, you may see changes in the color consistency. By reducing the time the print stays in extreme environmental conditions after being printed (especially very high humidity) you can reduce the color consistency problems.
- If you notice that there are color changes between different printers i.e. between the 750C and this printer, it is normal. There will be color differences between HP DesignJet Printers because the other Printers use a different type of ink.

Long Term Color Bleeding (Glossy Papers)

If you see the colors are bleeding into the paper i.e. the color is soaking into the paper making the lines fuzzy and bleary. This will be because of the humidity conditions that the printer is working under:

- Ask the customer to change the paper that they are printing with.
or
- Remove the printer from the high humidity conditions.

Media

Always make sure that the customer is using the appropriate media for the required image and that it is consistent with the software application being used. To ensure color accuracy and print quality performance of the Printer, only media types that have been certified for the Printer should be used. Use of non-HP media or HP media not certified for the printer may significantly reduce the color and print quality of the required images. For details of HP media, refer to the **User's Guide** or the **Media Guide for the HP Designjet Printers**.

NOTE

To have accurate colors, the media settings must match the type of media loaded in the printer.

If the customer is using non-HP media with HP drivers, the colors in the required print may not be accurate. Advise the customer to use HP media if they want to improve the accuracy of the colors.

There are Smears or Scratching on the Printed Media

This problem can appear on paper-based coated media if a lot of ink is printed quickly. The media cannot absorb the ink quickly enough and becomes distorted. As the printheads move over the media, the Printheads and the media come into contact with each other and the printed image is smeared.

- 1 Press the **Cancel** key on the front panel; if you continue to print, the paper may damage the printheads.
- 2 Cancel the print job from your computer application.
In order to obtain better results perform the following:
 - Use HP recommended media. If the image you are printing has intense color, use HP Heavy Coated Paper
 - Try to increase the print margins by relocating the image on the page from the software application.
 - If the customer is using 'Media Saving Options' from the advanced section of the HP- GL/2 Driver, try disabling one or both of the options 'auto rotate' and 'inked area'.





If the above fails to solve the problem of smears and scratching, change the media that the customer is using to a non-paper based media such as HP High Gloss Photo Paper.

Parts and Diagrams

7

Printer Support 7-2
Right Hand Cover 7-4
Left Hand Cover 7-6
Top Cover and Deflectors 7-8
Rollfeed Module 7-10
Back Platen Assembly 7-12
Electronics Module 7-14
Power Supply 7-16
Cutter Assemblies 7-18
Ink Delivery System 7-20
Service Station and Spittoon 7-22
Service Station Holder 7-24
Pinch-Wheel Assemblies 7-26
Scan-Axis Motor 7-28
Drive Roller Encoder Sensor 7-30
Print Platen Assembly 7-32
Carriage Assembly 7-34
Vacuum Fan 7-36
Interconnect Cable 7-38
Paper-Axis Motor 7-40
Drive Roller 7-42
Miscellaneous Items 7-44

Printer Support

Printer Support			
Reference on Drawing	HP Part Number	Quantity	Description/Comments
	C7782-60001	1	Bin Assembly (24" Model) - Flint Grey
	C7781-60005	1	Bin Assembly (24" Model) - Graphite Grey
	C7770-60023	1	Bin Assembly (42" Model) - Flint Grey
	C7780-60001	1	Bin Assembly (42" Model) - Graphite Grey
2	C7770-60082	2	Foot Assembly
3	C7770-60021	2	Legs Assembly
4	C7781-60004	1	X-Brace Assembly (24" Model)
	C7770-60020	1	X-Brace Assembly (42" Model)
-	C7770-60018	1	Hardware Kit (Includes Screw Drivers)

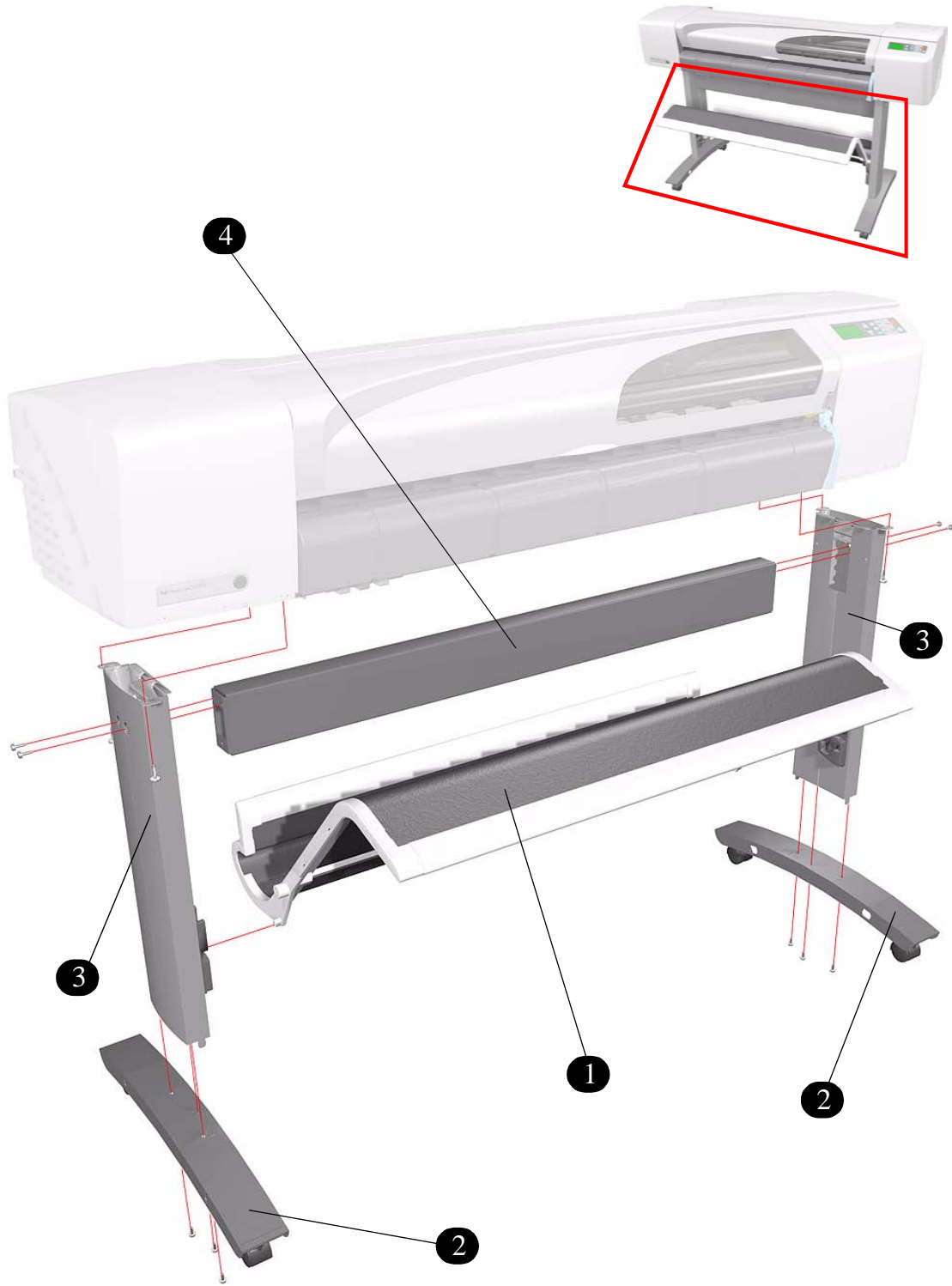

Figure 1: Printer Support

Right Hand Cover

Right Hand Cover			
Reference on Drawing	HP Part Number	Quantity	Description/Comments
1	C7769-60159	1	Right Hand Cover - Grey (HP DesignJet 500 Series Only)
	C7779-60159	1	Right Hand Cover - Black (HP DesignJet 800 Series Only)
2	0624-0771	5	Screws
3	C7769-60160	1	Trim Kit (Includes the front and back trims for the left and right sides)
4	C7769-60161	1	Front Panel

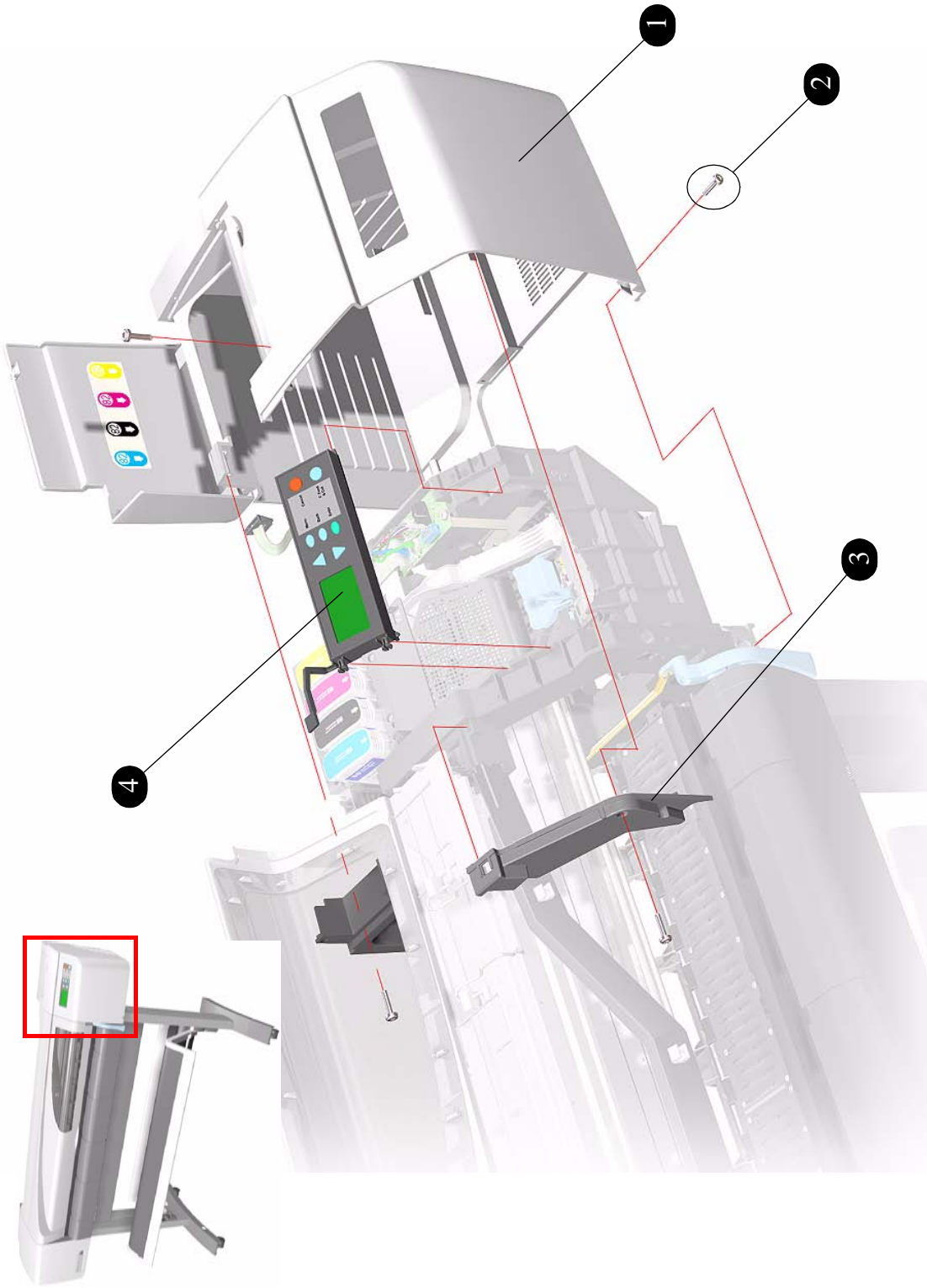



Figure 2: Right Hand Cover

Left Hand Cover

Left Hand Cover			
Reference on Drawing	HP Part Number	Quantity	Description/Comments
	C7769-60158	1	Left Hand Cover - Grey (HP DesignJet 500 Series Only)
	C7779-60158	1	Left Hand Cover - Black (HP DesignJet 800 Series Only)
2	0624-0771	5	Screws
3	C7769-60160	1	Trim Kit (Includes the front and back trims for the left and right sides)

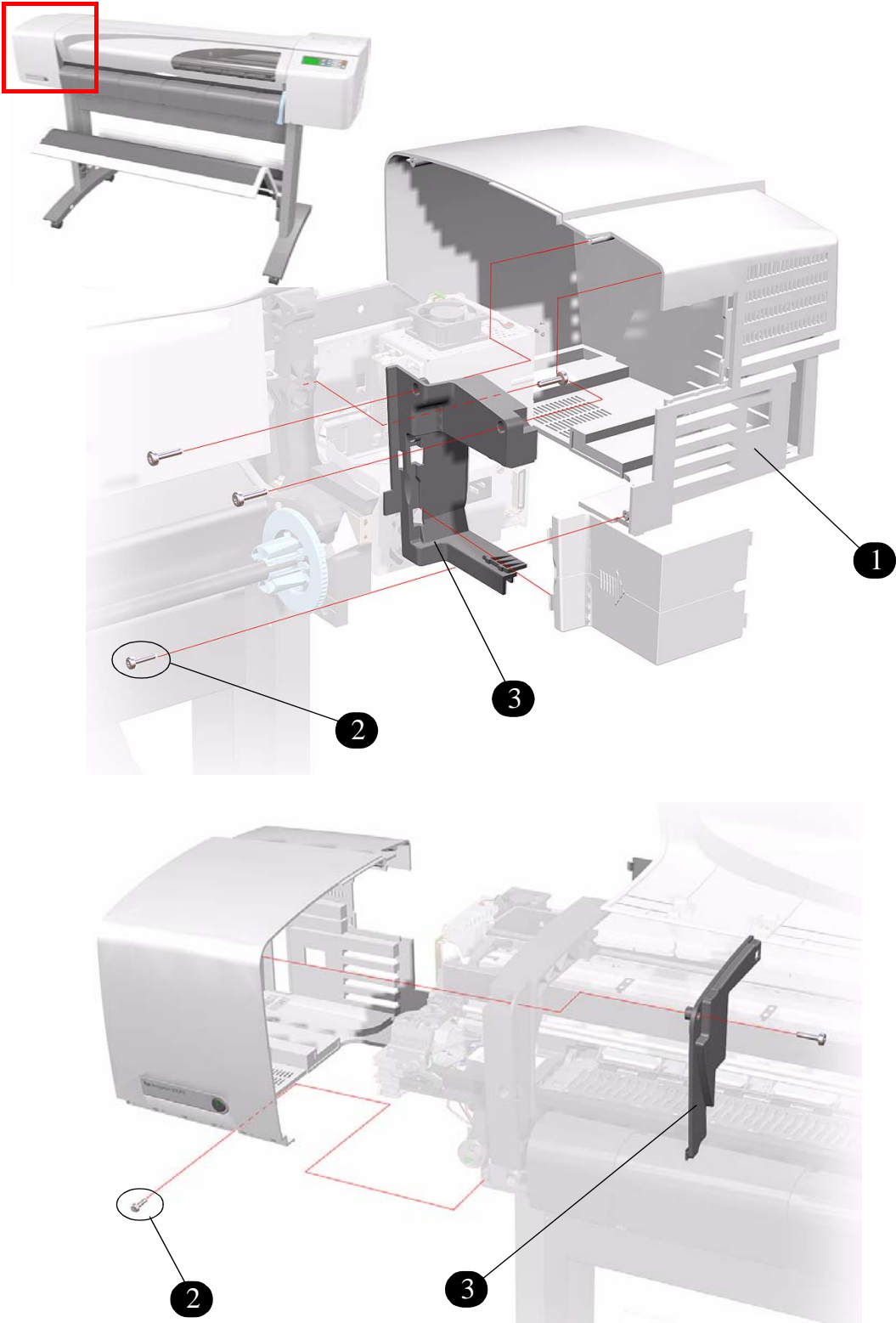

Figure 3: Left Hand Cover

Top Cover and Deflectors

Top Cover and Deflectors				
Reference on Drawing	HP Part Number	Quantity		Description/Comments
		24"	42"	
1	C7769-60154	1		Top Cover - Grey (HP DesignJet 500 Series Only)
	C7770-60154		1	Top Cover - Grey (HP DesignJet 500 Series Only)
	C7779-60154	1		Top Cover - Black (HP DesignJet 800 Series Only)
	C7780-60154		1	Top Cover - Black (HP DesignJet 800 Series Only)
2	0515-1743	2	3	Screws
3	C7769-60167	2	3	Media Deflectors (comes as a kit)

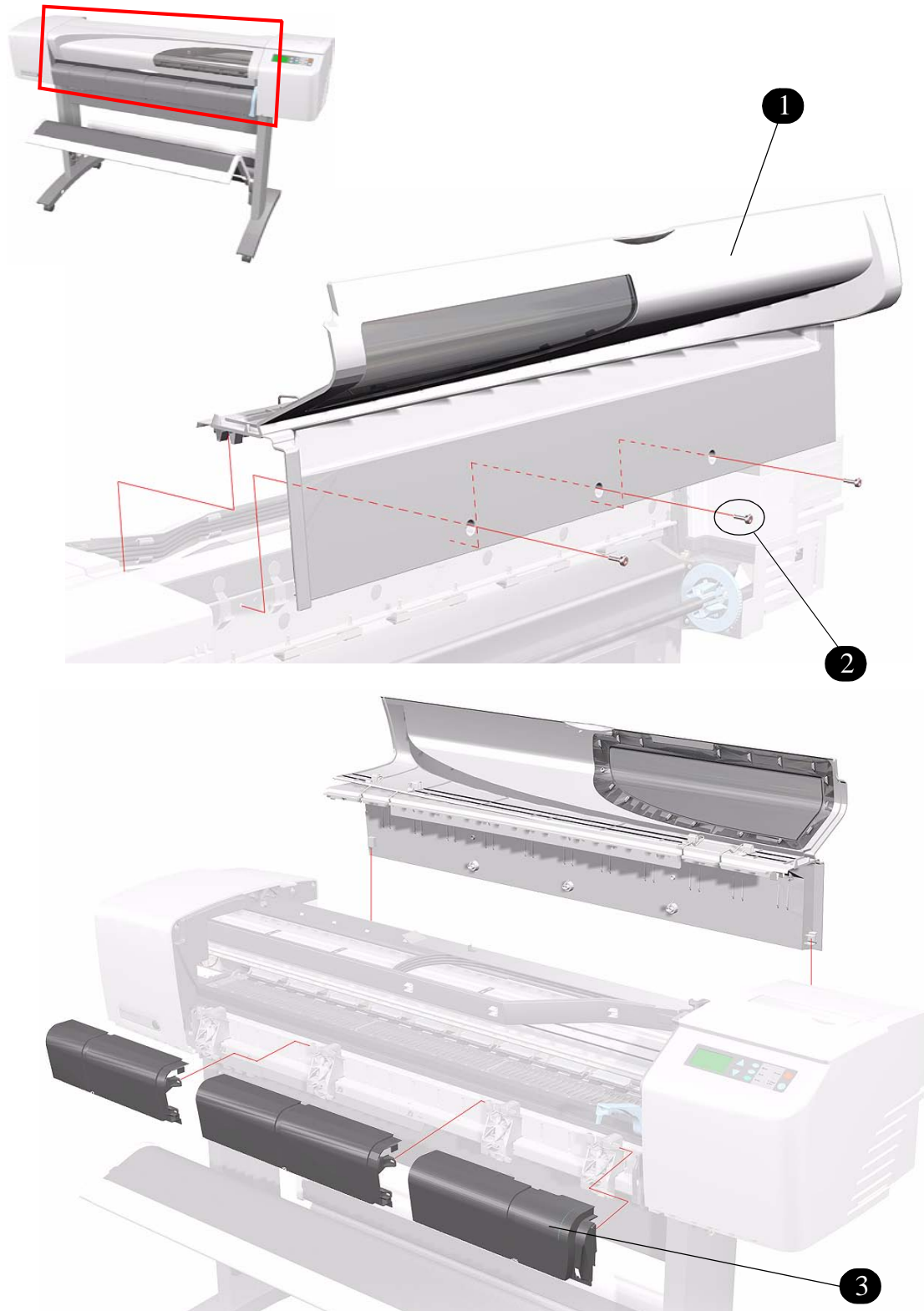

Figure 4: Top Cover and Deflectors

Rollfeed Module

Rollfeed Module			
Reference on Drawing	HP Part Number	Quantity	Description/Comments
1	C7769-60162	1	Rollfeed Module Kit
2	0624-0771	6	Screw Plas M4 1in
3	C7769-60184	1	Spindle (24" Model Only)
	C7770-60008	1	Spindle (42" Model Only)

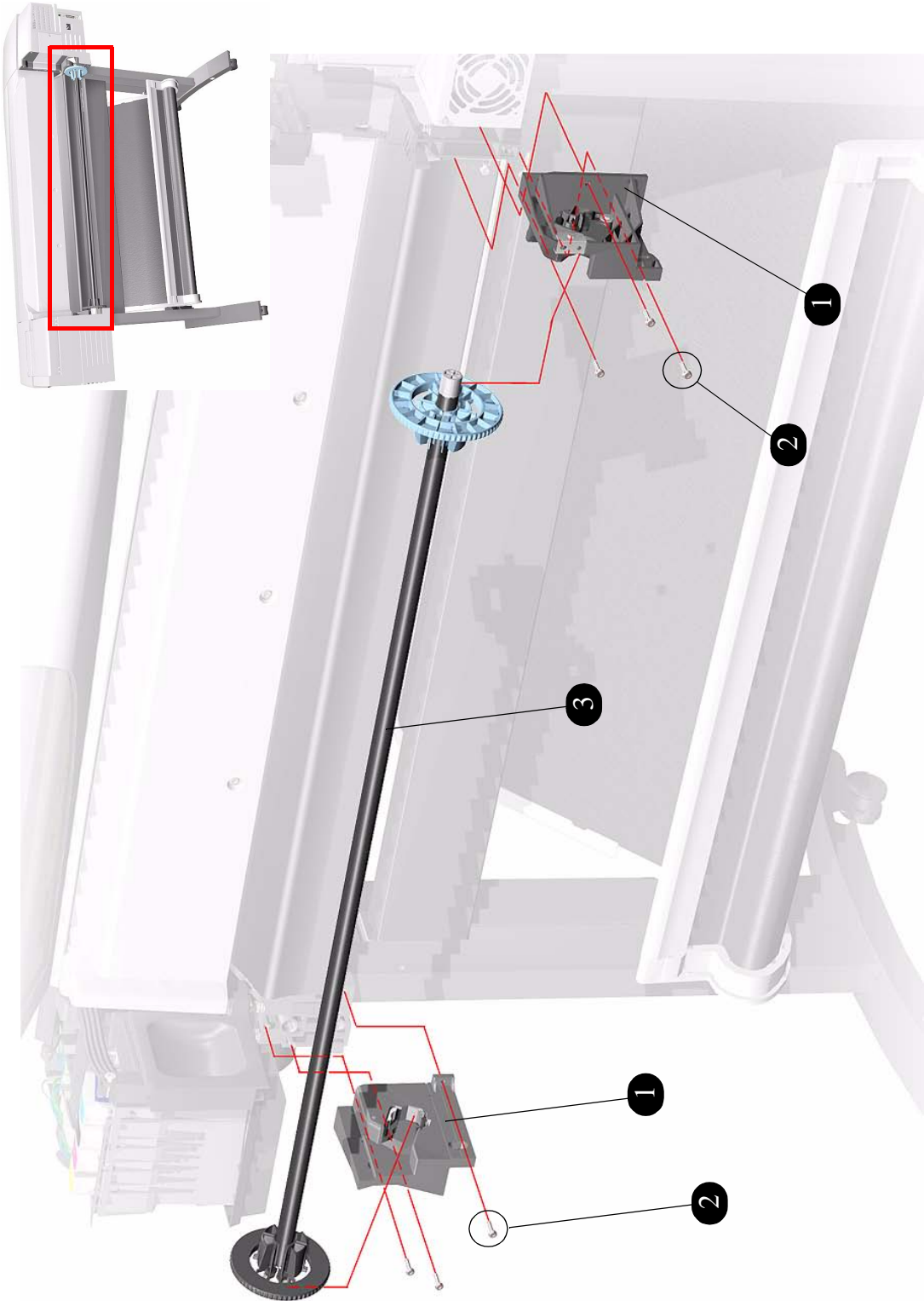

Figure 5: Rollfed Module

Back Platen Assembly

Back Platen Assembly			
Reference on Drawing	HP Part Number	Quantity	Description/Comments
1	C7769-60155	1	Back Platen (24" Model Only)
	C7770-60155	1	Back Platen (42" Model Only)
2	0624-0769	2	Screw
3	C7769-60168	1	Media Sensor

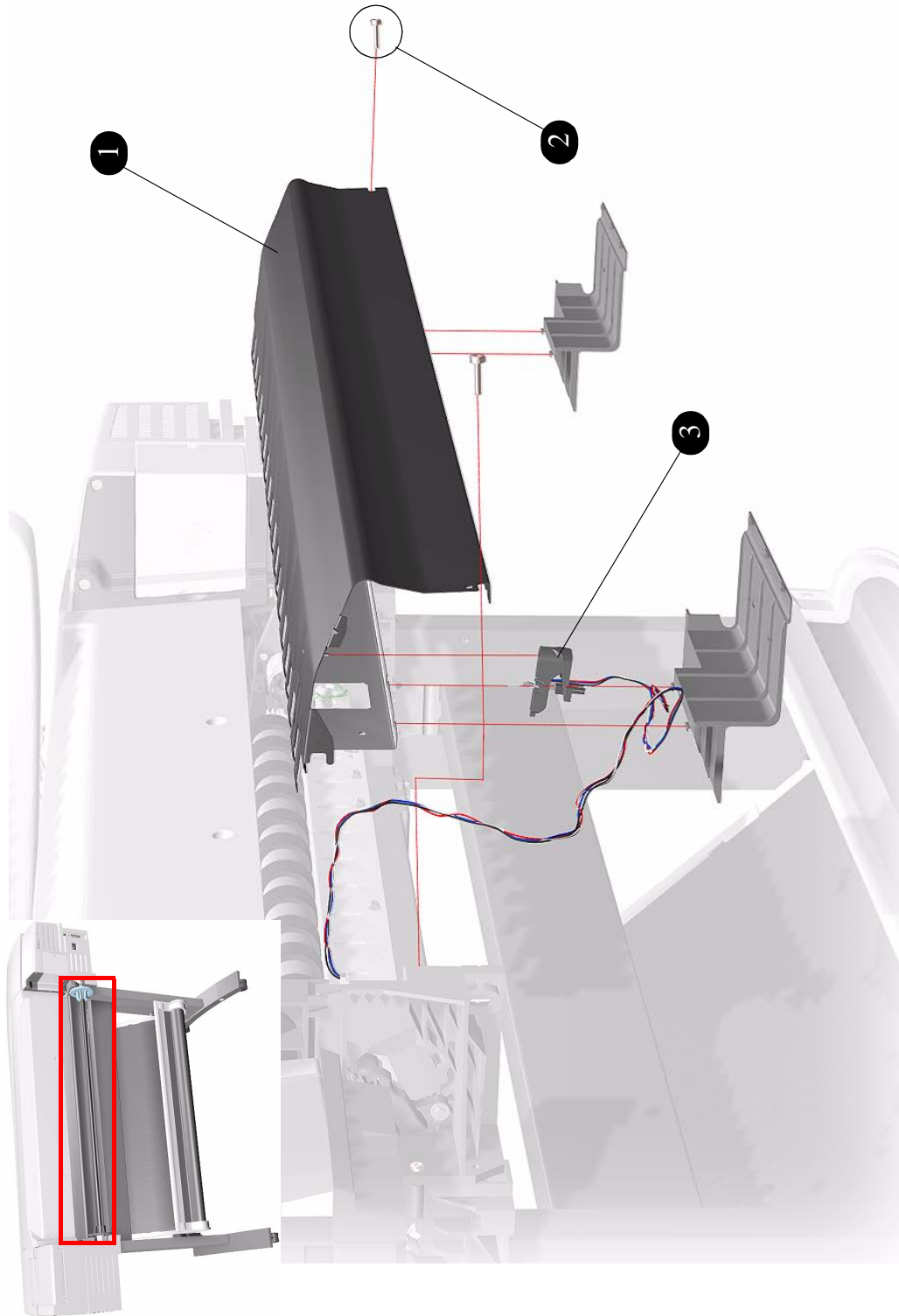

Figure 6: Back Platen Assembly

Electronics Module

Electronics Module			
Reference on Drawing	HP Part Number	Quantity	Description/Comments
1	C7779-60144	1	Electronics Module
2	0515-2200	3	Screw Tap M3 x 10 mm
3	J3113A	1	EIO Card
4	C7769-60143	1	Formatter (HP DesignJet 500PS, 800 and 800PS Only)
	C7772A	1	Formatter (HP DesignJet 500 Only)

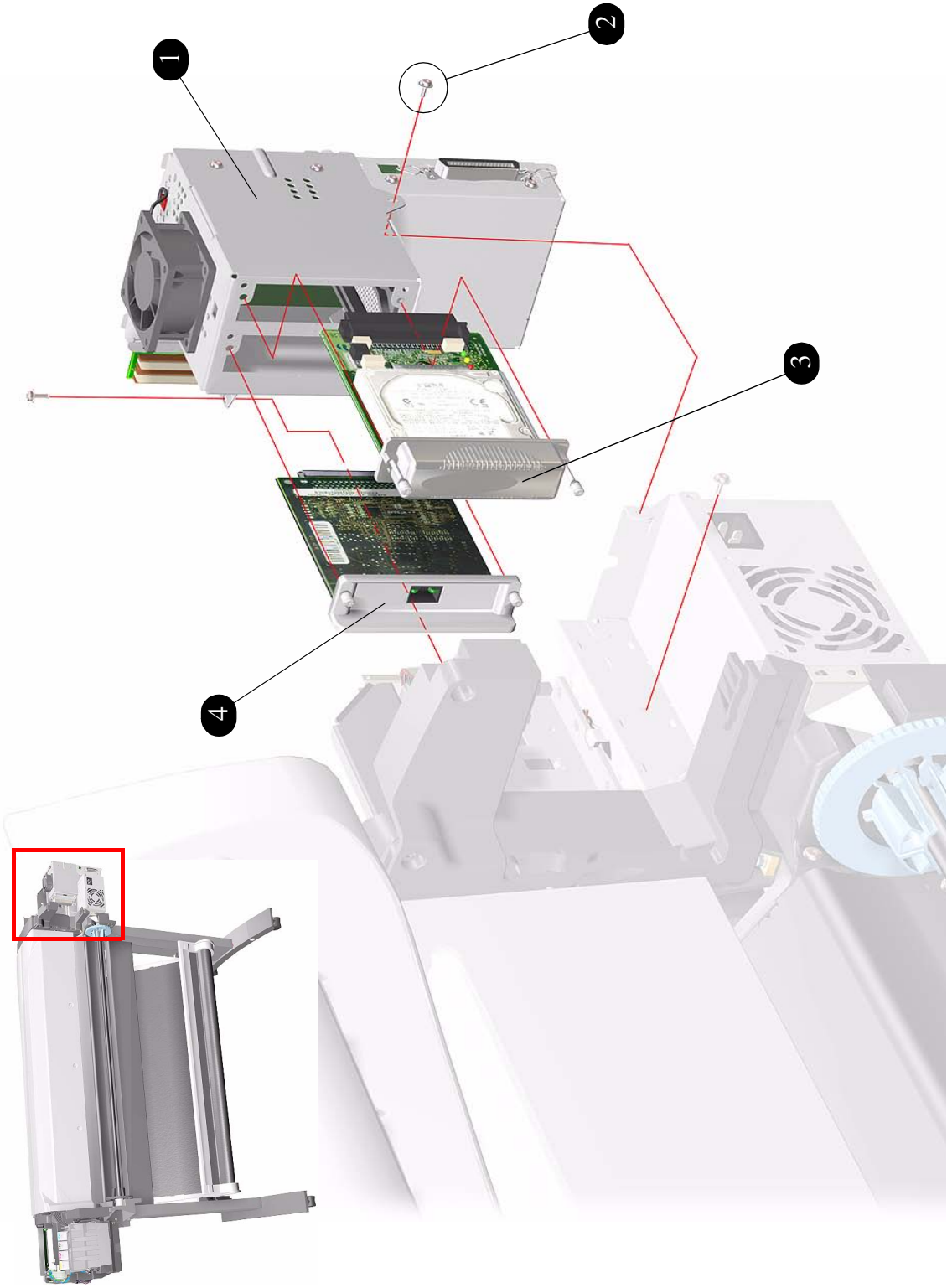

Figure 7: Electronics Module

Power Supply

Power Supply			
Reference on Drawing	HP Part Number	Quantity	Description/Comments
1	C7769-60145	1	Power Supply Unit
2	0515-2200	3	Screw Tap M3 x 10 mm

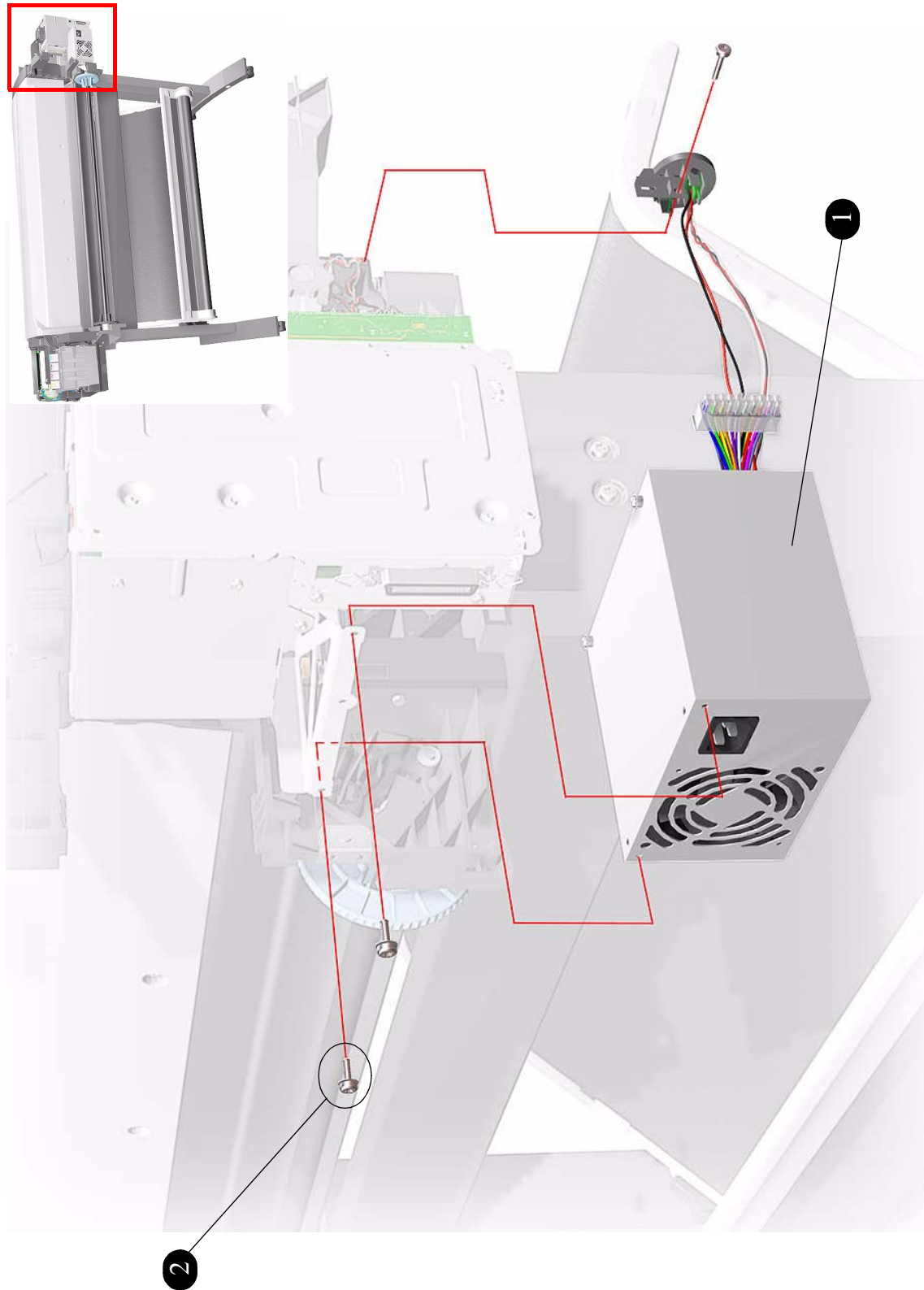

Figure 8: Power Supply

Cutter Assemblies

Cutter Assemblies			
Reference on Drawing	HP Part Number	Quantity	Description/Comments
1	C7769-60163	1	Cutter Assembly
2	C7769-60169	1	Cutter Bushing
3	C7769-60179	1	Cutter Guide (24" Model Only)
	C7769-60017	1	Cutter Guide (42" Model Only)
4	C7769-60170	1	Cutter Guide Bracket and Left Encoder Holder Kit
5	0515-2200	1	Screw (Cutter Guide Bracket)
6	0515-1743	2	Screw (Left Encoder Holder)

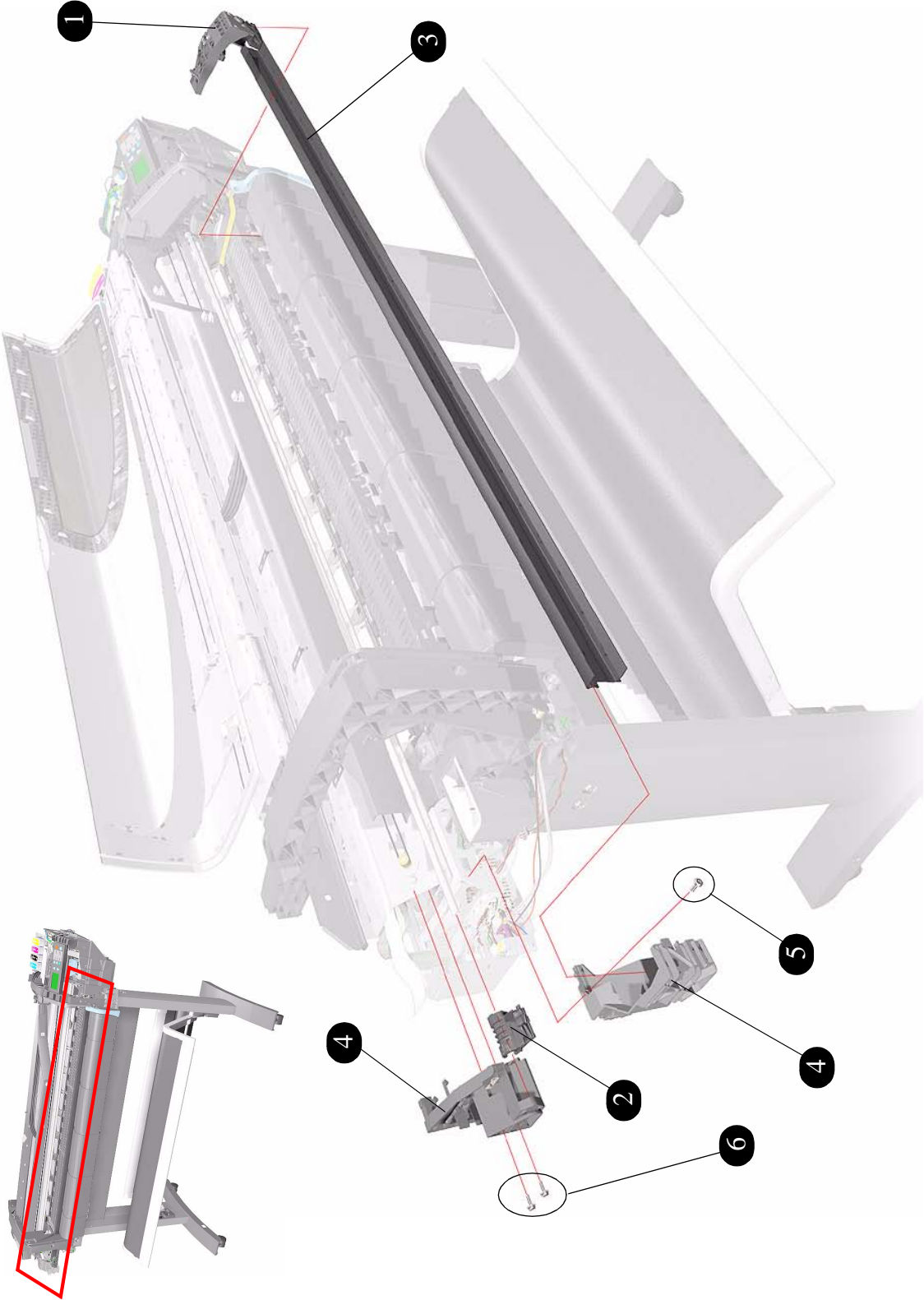

Figure 9: Cutter Assemblies

Ink Delivery System

Ink Delivery System			
Reference on Drawing	HP Part Number	Quantity	Description/Comments
1	C7769-60153	1	Tubes Assembly (24" Model Only)
	C7770-60153	1	Tubes Assembly (42" Model Only)
2	C7769-60148	1	Ink Supply Station
3	0624-0769	1	Screw Plas 6-19 0.5 in
4	C7769-60164	1	Start-up Printheads

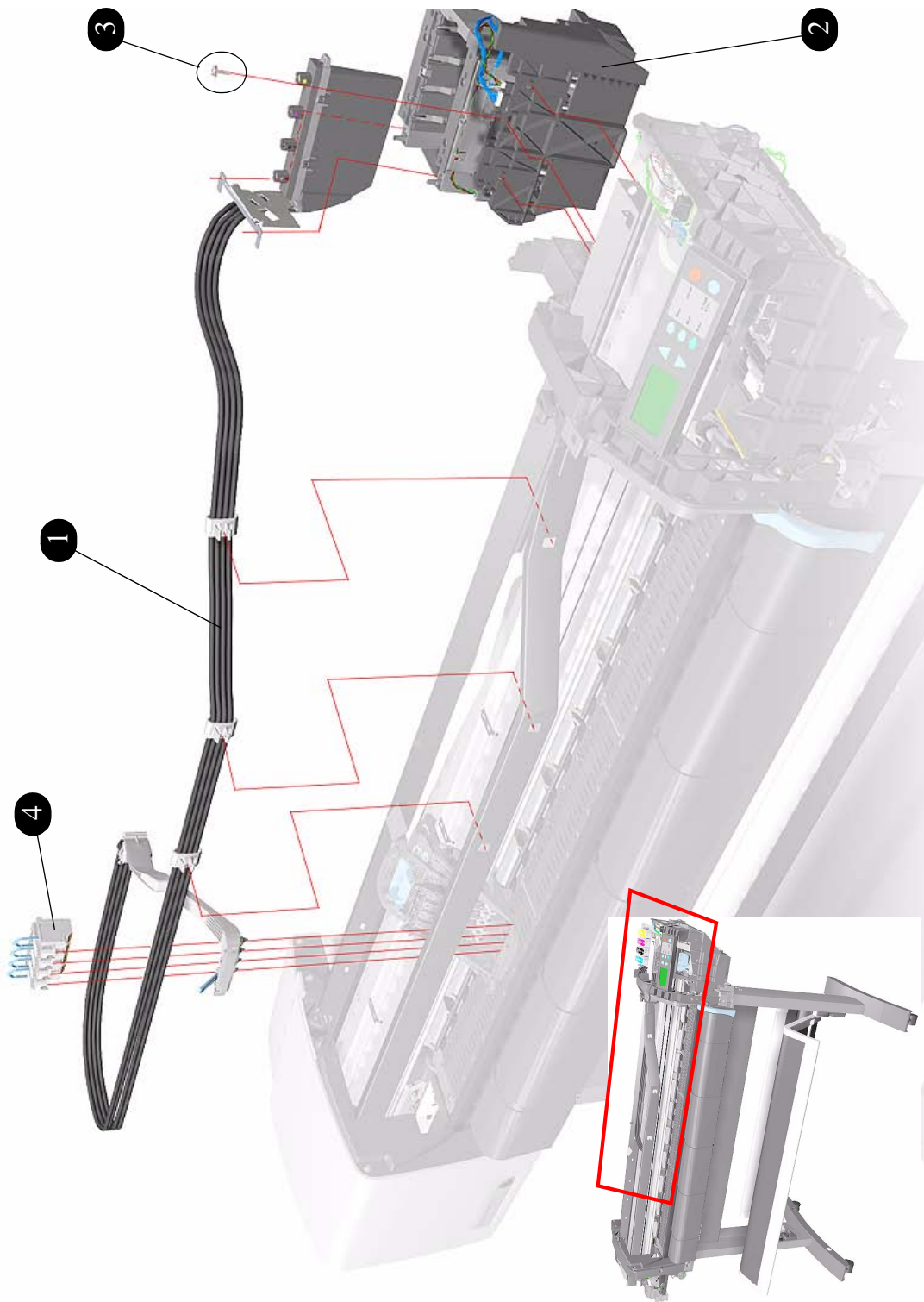

Figure 10: Ink Delivery System

Service Station and Spittoon

Service Station and Spittoon			
Reference on Drawing	HP Part Number	Quantity	Description/Comments
1	C7769-60149	1	Service Station/Aerosol Fan
2	0624-0769	2	Screw Plas 6-19 0.5 in
3	C7769-60165	1	Left Spittoon Assembly

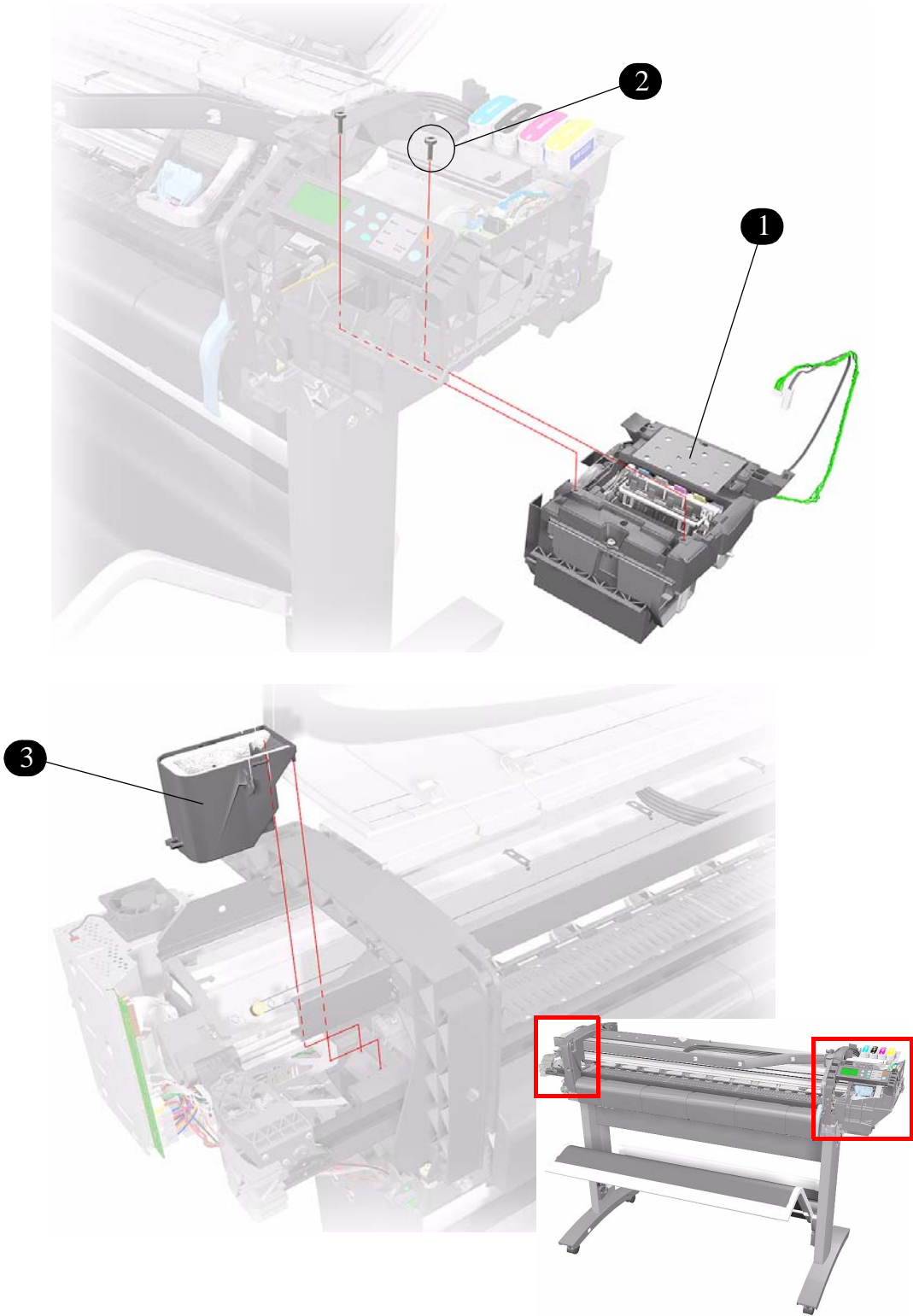

Figure 11: Service Station and Spittoon

Service Station Holder

Service Station Holder			
Reference on Drawing	HP Part Number	Quantity	Description/Comments
1	C7769-60156	1	Service Station Holder (Right Hand Bracket)
2	0515-2282	4	Screw
3	0624-0769	2	Screw
4	C7769-60173	1	Interconnect PCA
5	0624-0769	1	Screw
6	C7769-60176	1	Tensioner Assembly Kit

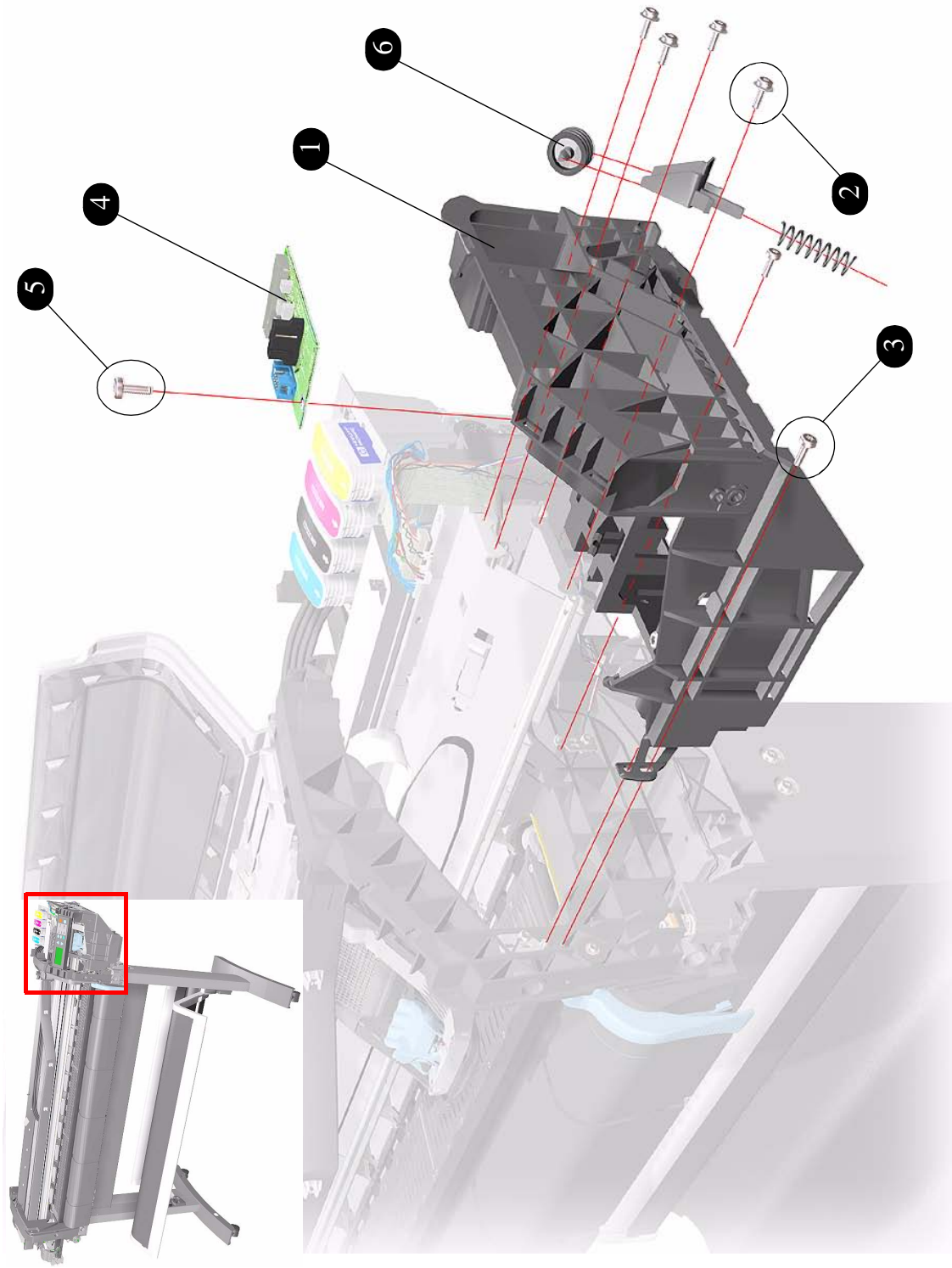

Figure 12: Service Station Holder

Pinch-Wheel Assemblies

Pinch-Wheel Assemblies			
Reference on Drawing	HP Part Number	Quantity	Description/Comments
1	C7769-60181	1	Pinch-Arm Mechanism (24" Model) *
	C7770-60015	1	Pinch-Arm Mechanism (42" Model) *
2	C7769-60175	3/5	Pinch-Arm
3	0515-2521	2	Screw
4	C7769-60074	1	Pinch-Arm Sensor
5	0624-0768	1	Screw

* Pinch Arm Mechanism includes the Pinch Arm Lever.

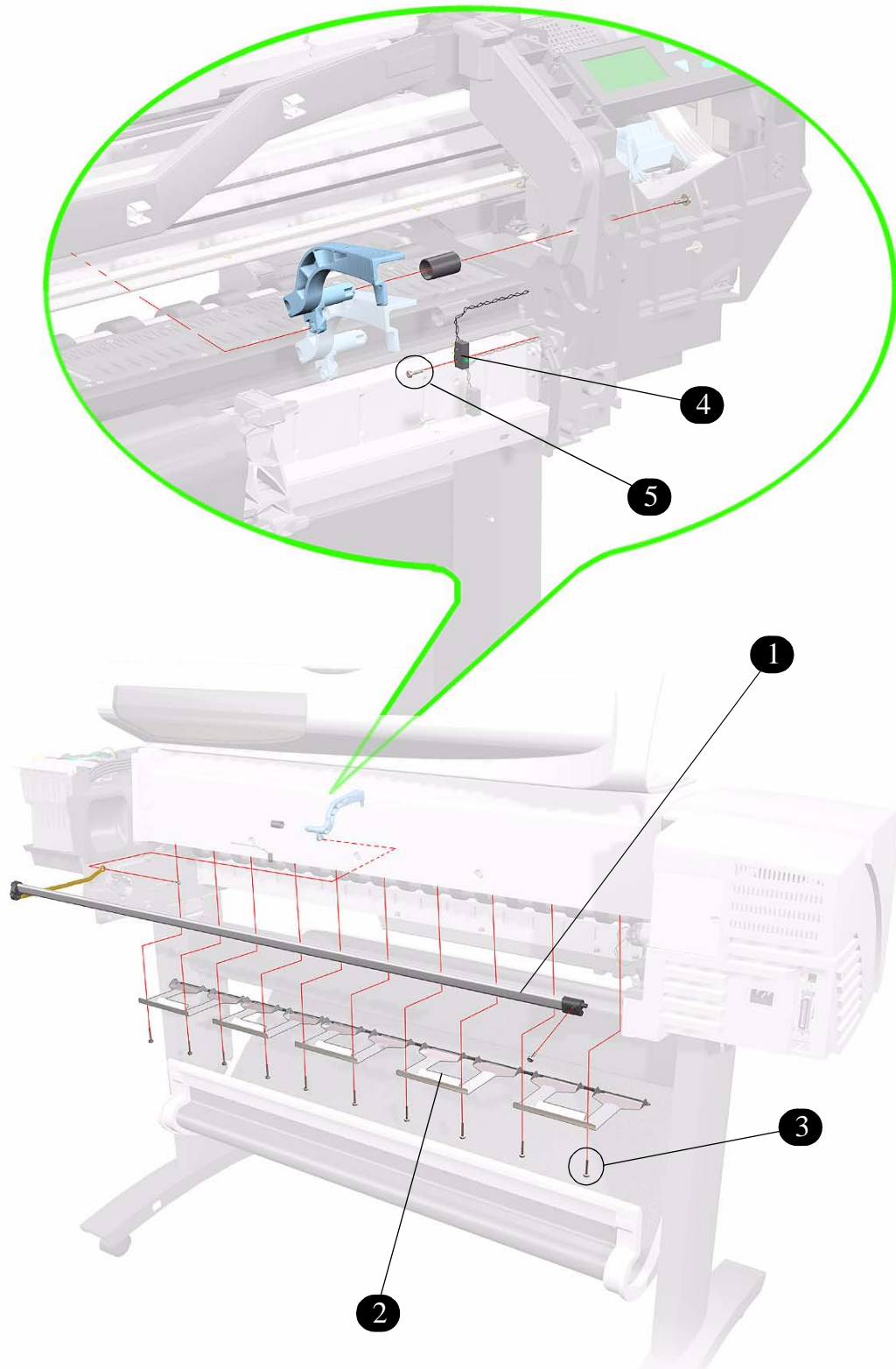

Figure 13: Pinch-Wheel Assemblies

Scan-Axis Motor

Scan-Axis Motor			
Reference on Drawing	HP Part Number	Quantity	Description/Comments
1	C7769-60146	1	Scan-Axis Motor
2	0515-2282	2	Screw



Figure 14: Scan-Axis Motor

Drive Roller Encoder Sensor

Drive Roller Encoder Sensor			
Reference on Drawing	HP Part Number	Quantity	Description/Comments
1	C7769-60171	1	Drive Roller Encoder Sensor Cover Kit
2	0624-0768	1	Screw
3	C7769-60172	1	Drive Roller Encoder Sensor
4	0624-0768	1	Screw

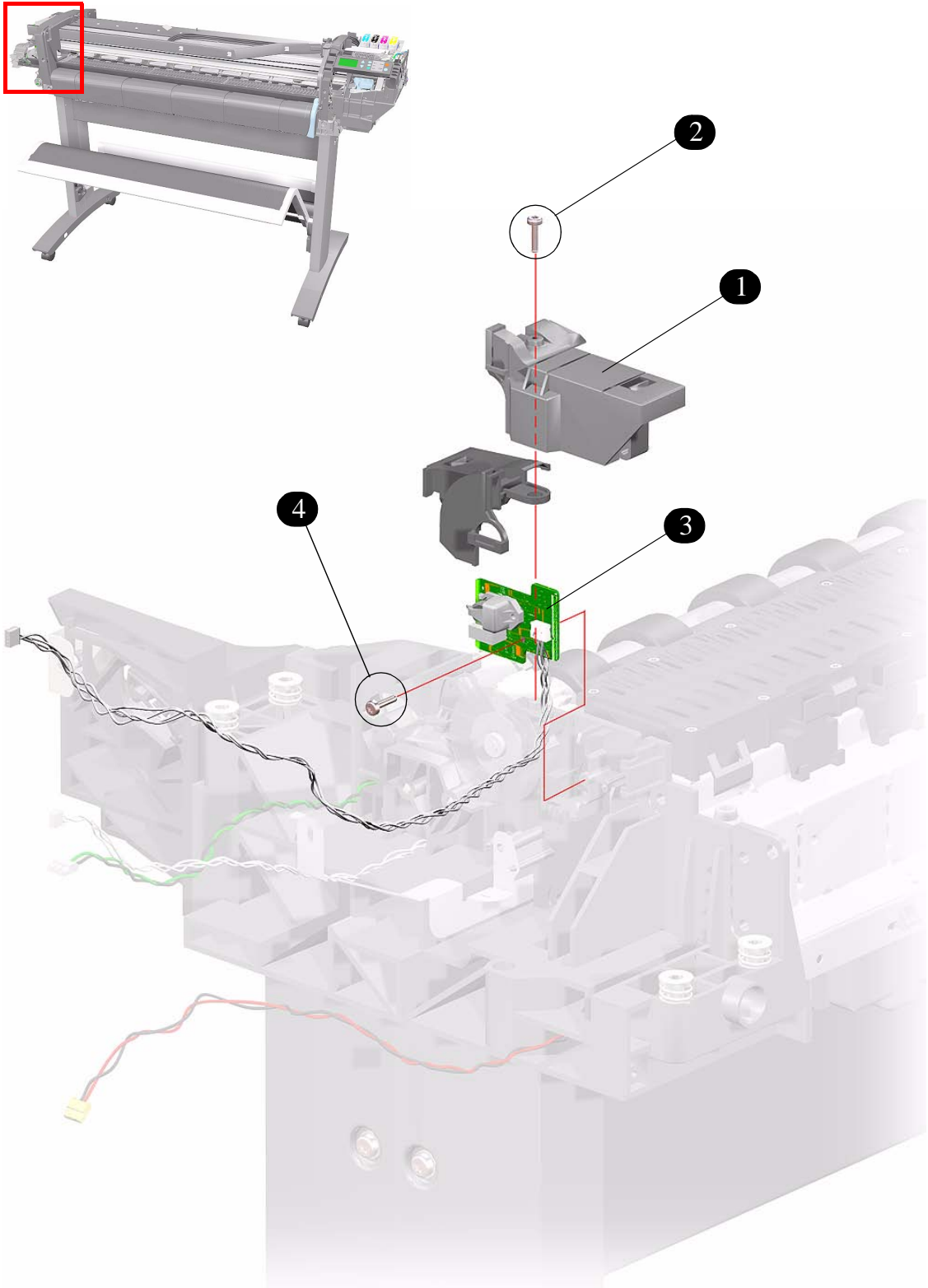

Figure 15: Drive Roller Encoder Sensor

Print Platen Assembly

Print Platen Assembly				
Reference on Drawing	HP Part Number	Quantity		Description/Comments
		24"	42"	
1	C7769-60174	1	1	Print Platen Kit (Includes parts for both the 24" and 42" Models)
2	0624-0768	31	38	Screws

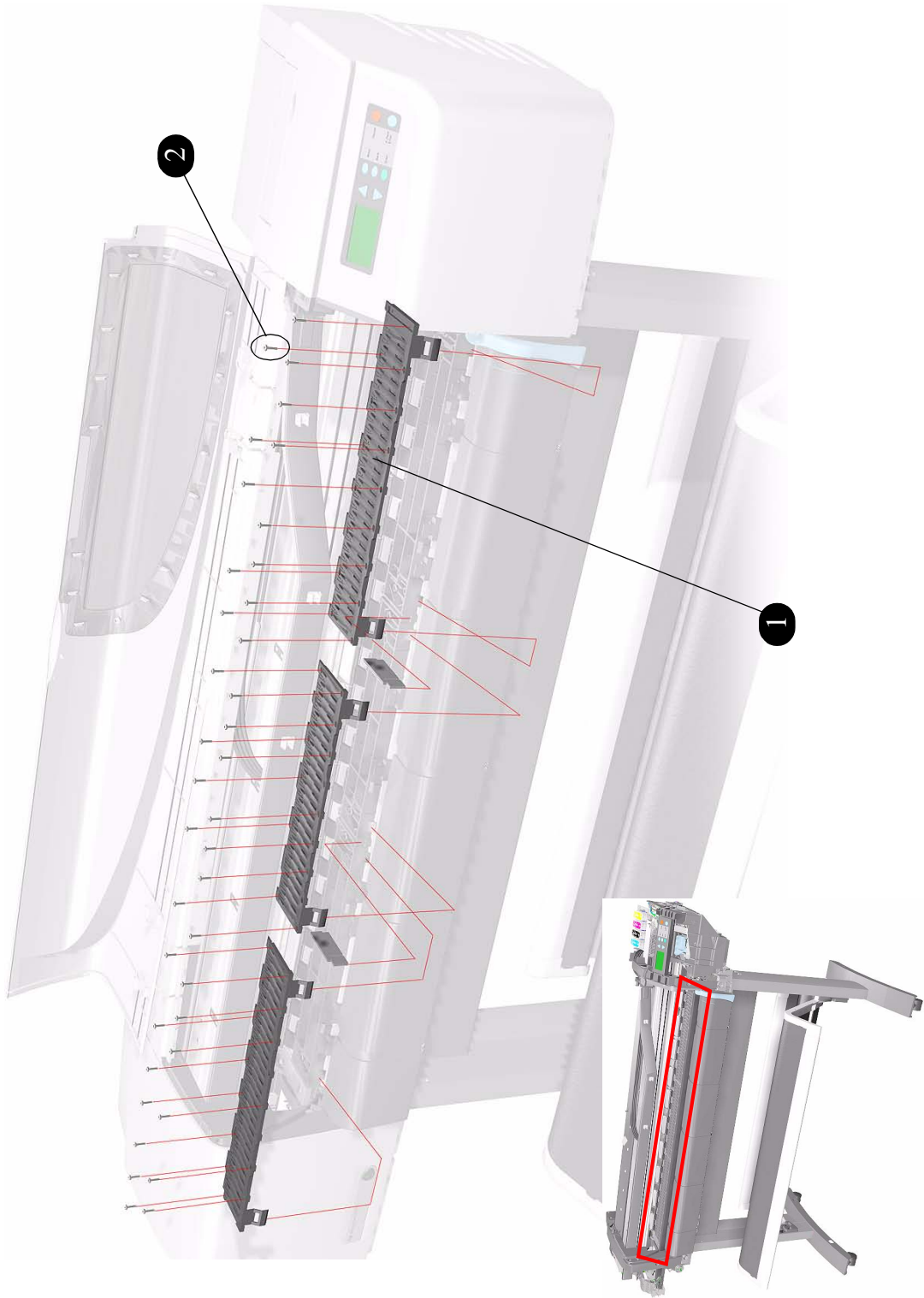

Figure 16: Print Platen Assembly

Carriage Assembly

Carriage Assembly			
Reference on Drawing	HP Part Number	Quantity	Description/Comments
1	C7769-60151	1	Carriage Assembly
2	C7769-60147	1	Trailing Cable (24" Model Only)
	C7770-60147	1	Trailing Cable (42" Model Only)
3	C7769-60182	1	Belt (24" Model Only)
	C7770-60014	1	Belt (42" Model Only)
4	C7769-60183	1	Encoder Strip (24" Model Only)
	C7770-60013	1	Encoder Strip (42" Model Only)
5	0624-0769	1	Screw

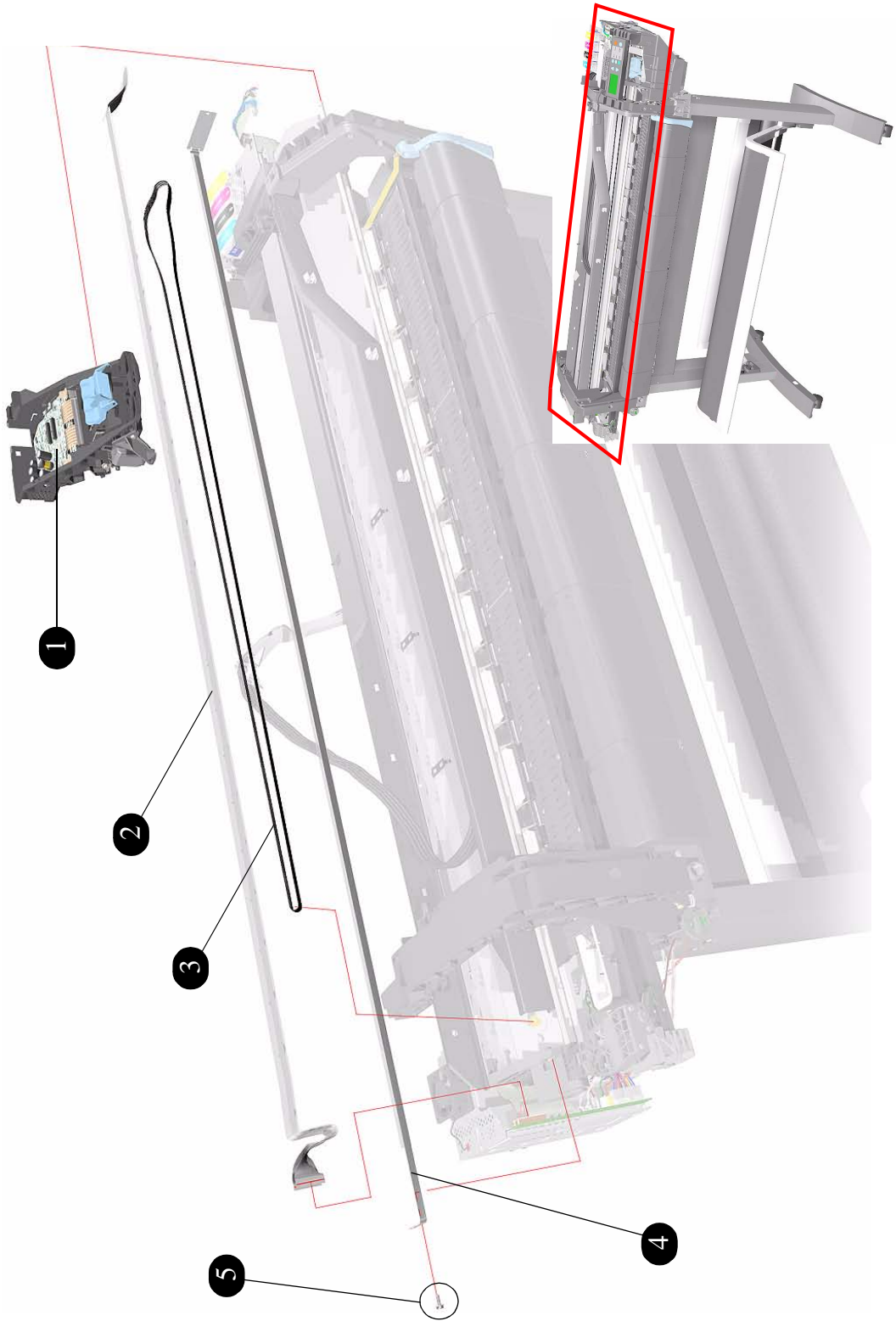

Figure 17: Carriage Assembly

Vacuum Fan

Vacuum Fan			
Reference on Drawing	HP Part Number	Quantity	Description/Comments
1	C7769-60150	1	Vacuum Fan



Figure 18: Vacuum Fan

Interconnect Cable

Interconnect Cable			
Reference on Drawing	HP Part Number	Quantity	Description/Comments
1	C7769-60180	1	Interconnect Cable (24" Model Only)
	C7770-60016	1	Interconnect Cable (42" Model Only)

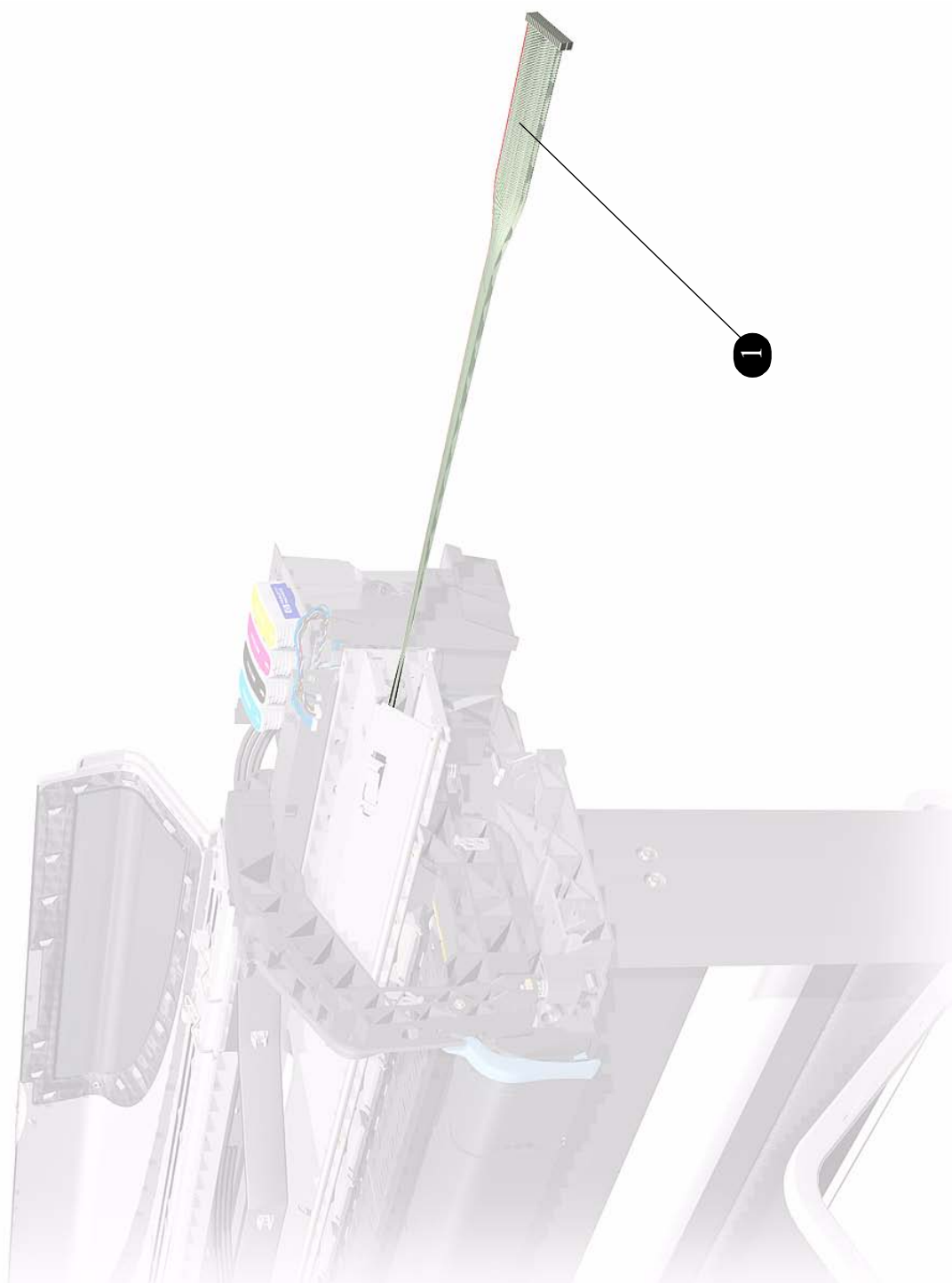

Figure 19: Interconnect Cable

Paper-Axis Motor

Paper-Axis Motor			
Reference on Drawing	HP Part Number	Quantity	Description/Comments
1	C7769-60152	1	Paper-Axis Motor Assembly
2	0515-2246	2	Screw

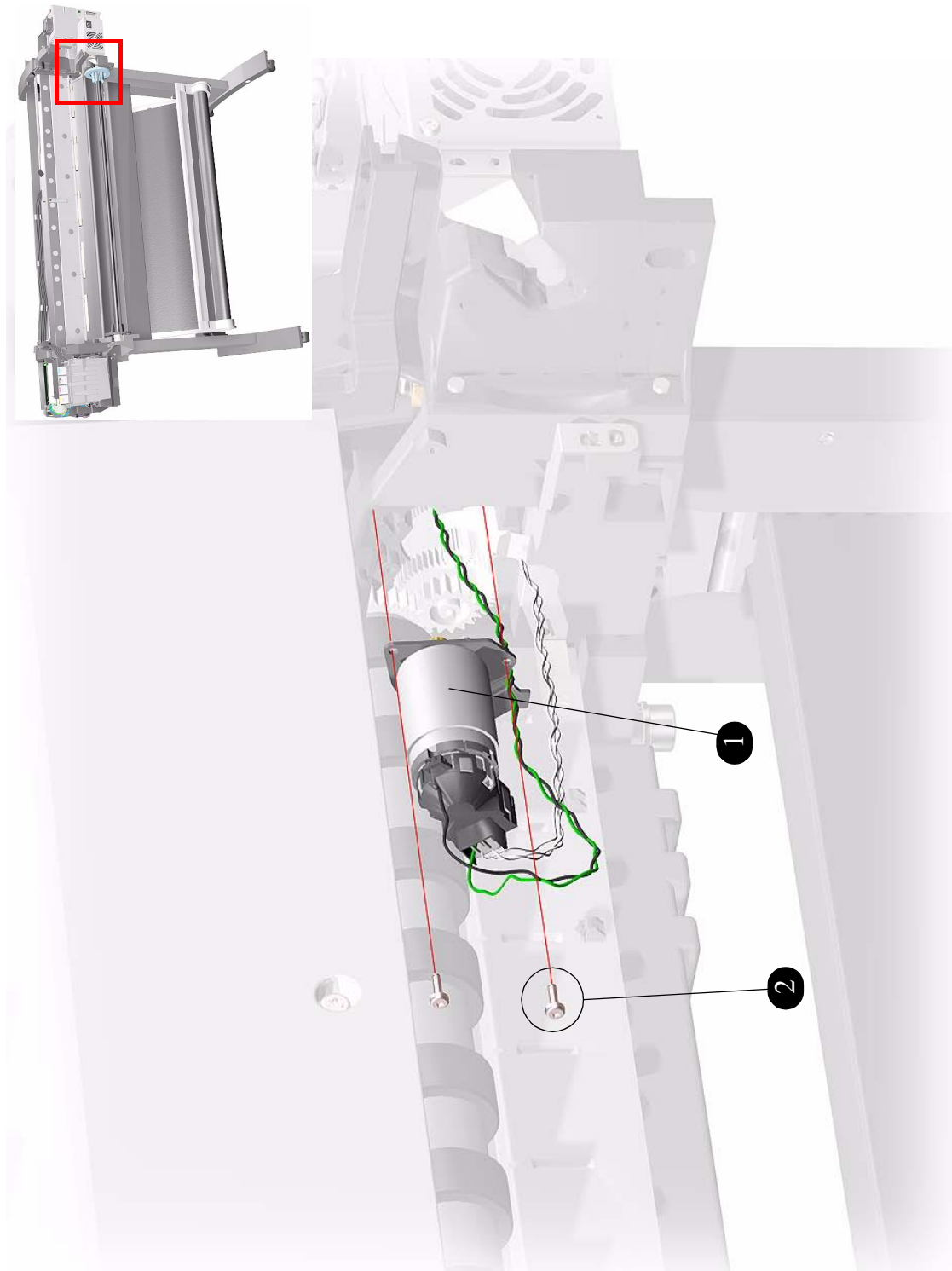

Figure 20: Paper-Axis Motor

Drive Roller

Drive Roller			
Reference on Drawing	HP Part Number	Quantity	Description/Comments
1	C7769-60157	1	Drive Roller Kit (24" Model Only)
	C7770-60157	1	Drive Roller Kit (42" Model Only)
2	C7769-60177	1	Transmission Gear Kit

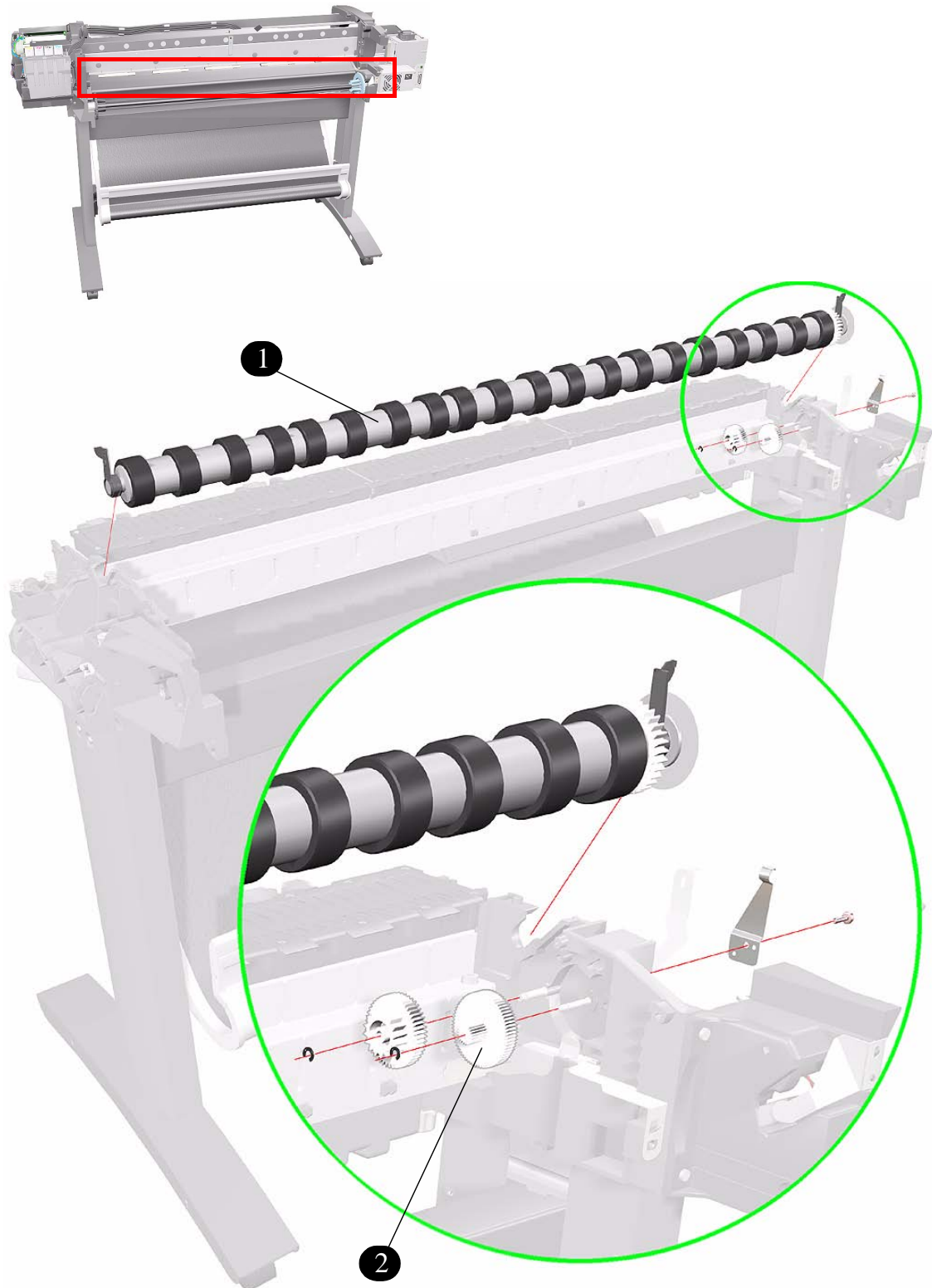

Figure 21: Drive Roller

Miscellaneous Items

Miscellaneous Items			
Reference on Drawing	HP Part Number	Quantity	Description/Comments
-	C7769-60185	1	Repackaging Kit (24" Model Only)
-	C7770-60007	1	Repackaging Kit (42" Model Only)
-	C7769-60178	1	Screw Kit

Removal and Installation

8

Screw Types 8-4
Left Hand Cover 8-5
Right Hand Cover 8-7
Front Panel 8-9
Window and Top Cover 8-10
Media Deflectors 8-11
Left End Roll-Feed 8-13
Right End Roll-Feed 8-15
Back Platen 8-17
Media Sensor 8-19
Formatter 8-20
LAN Card 8-21
Spittoon 8-23
Electronics Module 8-24
Power Supply 8-27
Scan-Axis Motor Assembly 8-29
Cutter Assembly 8-32
Left Encoder Holder 8-33
Cutter Bushing 8-35
Cutter Guide Bracket 8-36
Drive Roller Encoder Sensor 8-38
Trailing Cable 8-40
Ink Supply Station 8-48
Interconnect PCA 8-50
Service Station and Aerosol Fan 8-52
Cutter Guide 8-55
Print Platen 8-56
Service Station Holder 8-57
Interconnect Cable 8-59
Ink Supply Tubes 8-60
Vacuum Fan 8-64
Pinch-Arm 8-66
Pinch-Arm Mechanism 8-67
Pinch-Arm Lever 8-69
Pinch-Arm Sensor 8-71
Fork Idler, Tensioner and Idler Pulley 8-74
Encoder Strip 8-76
Carriage Assembly (Including Belt) 8-78
Paper-Axis Motor 8-84
Drive Roller 8-86
Gear Assemblies 8-92

Introduction

This chapter is a step by step guide to the removal and installation of the key components in the printer. You may find it useful to tick off the steps as they are performed. Use the illustration at each procedure to identify the parts referred to in the text.

The procedures appear in order of removal. So the whole machine can be stripped down by starting at the beginning of this chapter and working through the subsequent procedures.

NOTE

Before using this chapter to remove and install a new component, always make sure that you have performed the relevant service test from Chapter 4. If the test passes you will not need to replace the component.

Safety Precautions

Review WARNING and CAUTION symbols and instructions before you service the printer. Follow these warnings and cautions for your protection and to avoid damaging the printer.

WARNING

Serious shock hazard leading to death or injury may result if you do not take the following precautions:

Ensure that the ac power outlet (mains) has a protective earth (ground) terminal.

Switch the plotter off, and disconnect it from the power source prior to performing any maintenance.

Prevent water or other liquids from running onto electrical components or circuits, or through openings in the module.

Electrostatic Discharge (ESD) Precautions

To prevent damage to the Printer circuits from high-voltage electrostatic discharge (ESD):

1. Do not wear clothing that is subject to static build-up.
2. Do not handle integrated circuits (ICs) in carpeted areas.
3. Do not remove an IC or a printed circuit assembly (PCA) from its conductive foam pad or conductive packaging until you are ready to install it.
4. Ground (earth) your body while disassembling and working on the Printer.
5. After removing a cover from the Printer, attach an earthing (ground) lead between the PCA common and earth ground. Touch all tools to earth ground to remove static charges before using them on the Printer.
6. After removing any PCA from the Printer, place it on a conductive foam pad or into its conductive packaging to prevent ESD damage to any ICs on the PCA.

Required Tools

The following tools are required to disassemble and repair the Printer.

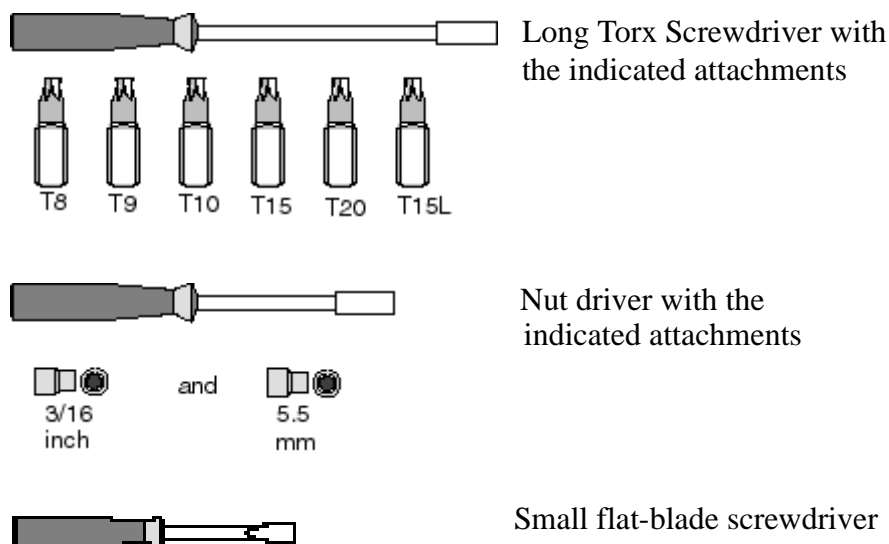

Screw Types

Type	Torx	Length (mm)	Head Type	Thread Type	Part Number
A	T-20	17	Pan	Taptite	0515-1743
B	T-10	8.0	Pan	Taptite	0515-2200
C	T-20	10	Pan	Taptite	0515-2282
D	T-10	17.5	Pan Washer	Plastite	0515-2675
E	T-15	12.7	Pan	Plastite	0624-0769
F	T-15	20	Pan	Plastite	0624-0771
G	T-8	12.7	Pan	Plastite	0624-0768
H	T-20	35	Pan	Taptite	0515-2521
I	T-15	9.5	Pan	Plastite	0515-2981
J	T-10	8	Pan	Machined	0515-2246

Left Hand Cover

Removal

WARNING Switch off the printer and remove the power cable.

NOTE Refer to the table on Page 8-4 for information on screw types.

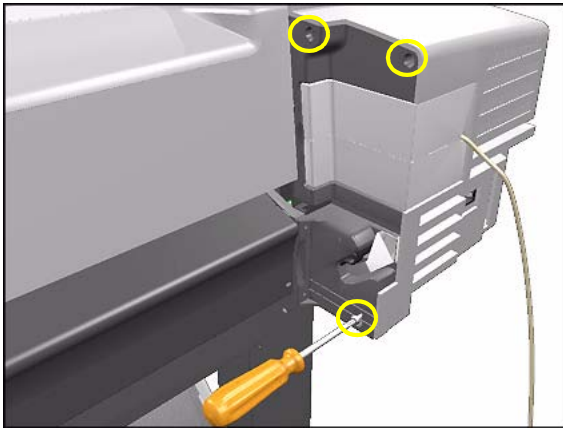

1. Remove the Spindle.
2. Remove 3 T-20 screws (**Type F**) from the Rear of the Left Hand Cover.

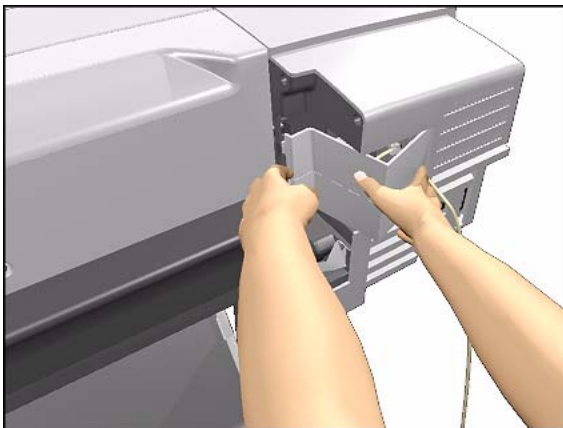

3. Remove the LAN Card Cover from the back of the Left Hand Cover.

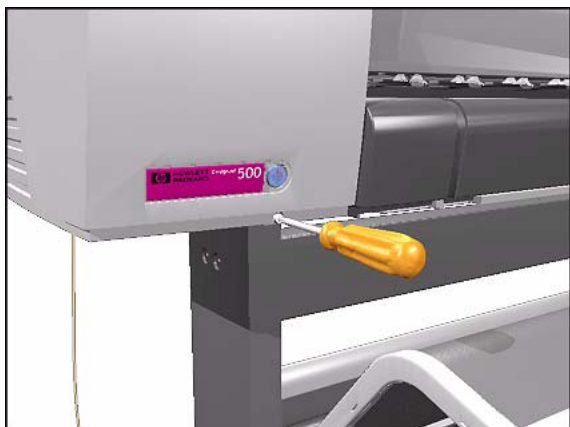

4. Remove 1 T-20 screw (**Type F**) from the front of Left Hand Cover.



5. Open the Window and remove 1 T-20 screw (**Type F**) from the side-plate.

NOTE Be careful not to drop the screw into the Printer.

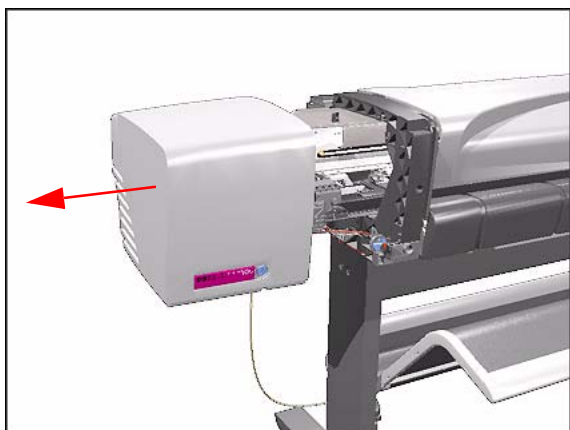

6. Remove the Left Hand Cover.

Right Hand Cover

Removal

WARNING Switch off the printer and remove the power cable.

NOTE Refer to the table on Page 8-4 for information on screw types.

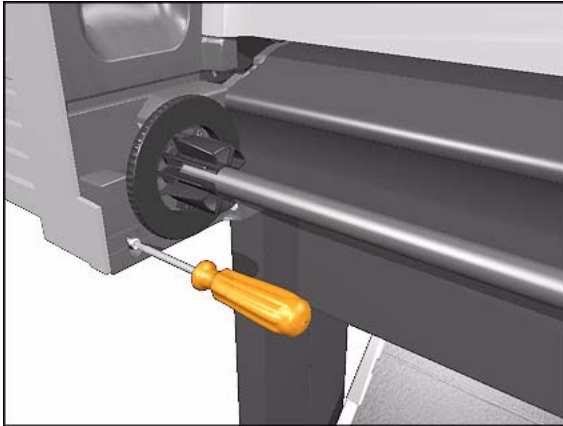

1. Remove 1 T-20 screw (**Type F**) from the back of the Right Hand Cover.

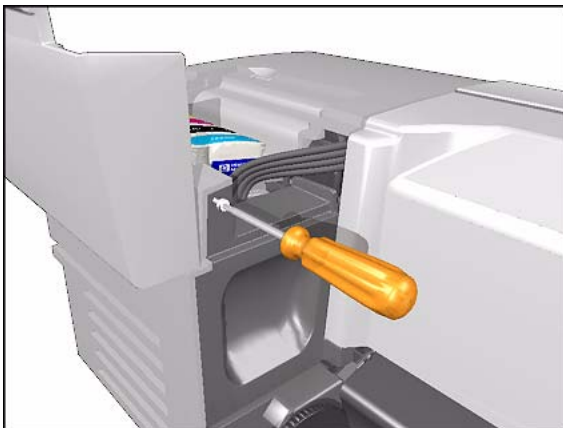

2. Open the Ink Cartridge Door and remove 1 T-20 screw (**Type F**) from the back of the Right Hand Cover.

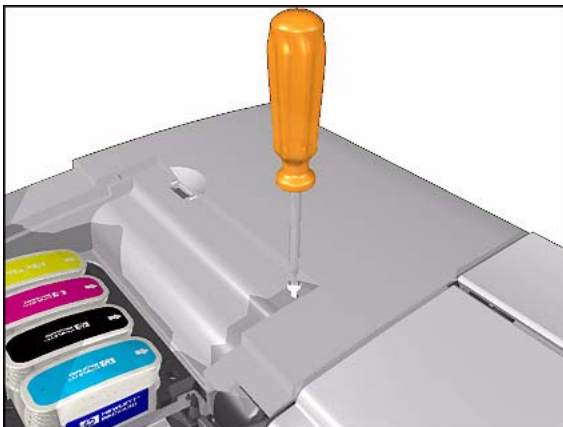

3. Keep the Ink Cartridge Door open and remove 1 T-20 screw (**Type F**) from the top of the Right Hand Cover.

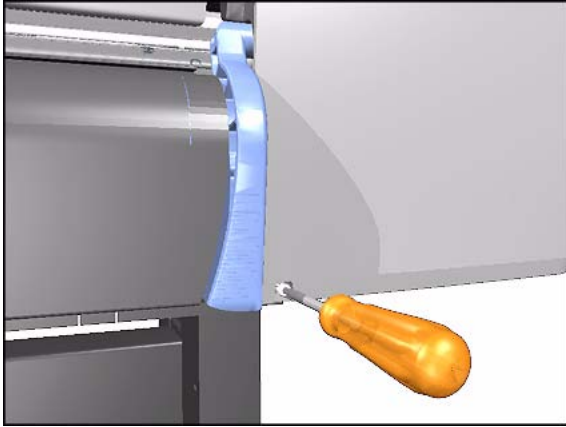

4. Remove 1 T-20 screw (**Type F**) from the front of the Right Hand Cover.

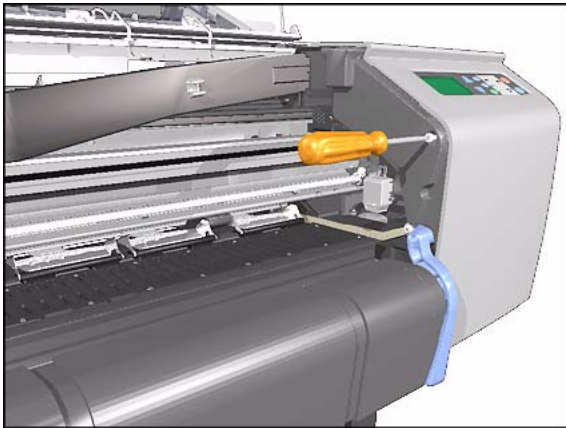

5. Open the Window and remove 1 T-20 screw (**Type F**) from the side plate.

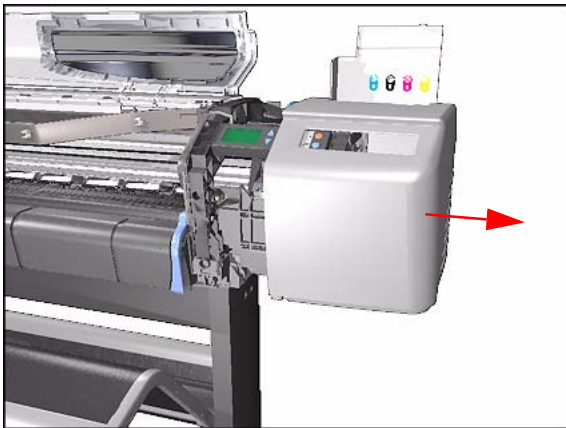

6. Remove the Right Hand Cover.

NOTE Always keep the Ink Cartridge door open when removing/installing the Right Hand Cover.

Front Panel

Removal

WARNING Switch off the printer and remove the power cable.

1. Remove the the Right Hand Cover - Refer to Page 8-7.
2. Remove the Right Hand Trim.

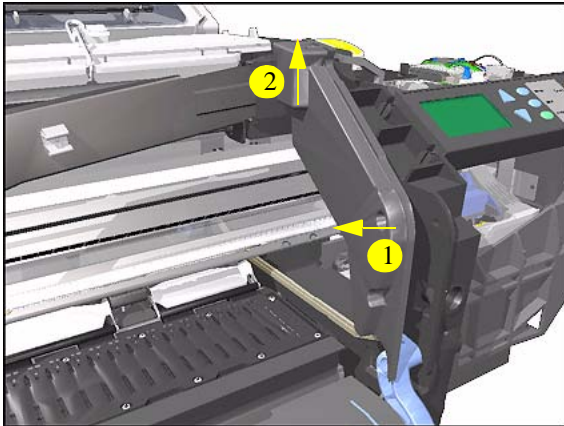

3. Disconnect Front Panel Connector from the ISS PCA.

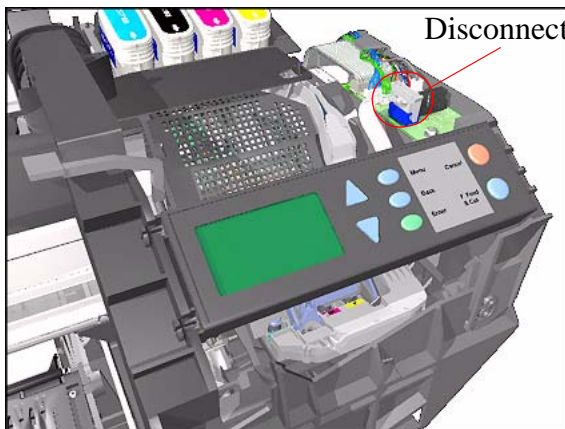

4. Unclip the Front Panel and remove from the Printer.

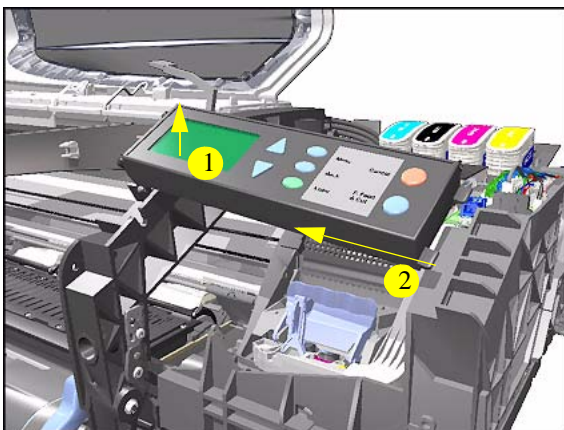

Window and Top Cover

Removal

WARNING Switch off the printer and remove the power cord.

NOTE Refer to the table on Page 8-4 for information on screw types.

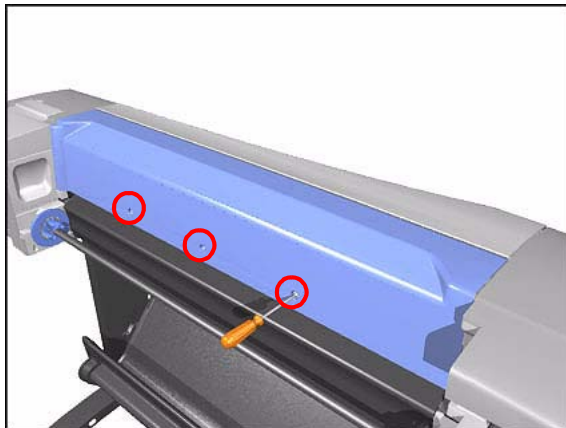

1. Remove the following screws (**Type A**) from the rear that attach the Top Cover to the Printer:
 - 2 T-20 screws for the 24" model.
 - 3 T-20 screws for the 42" model.

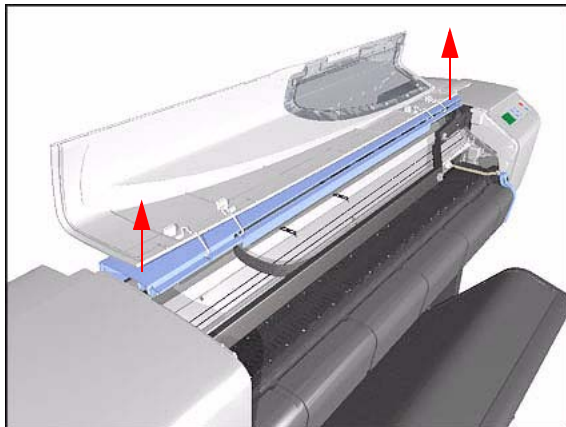

2. Raise Window and unclip at both ends.

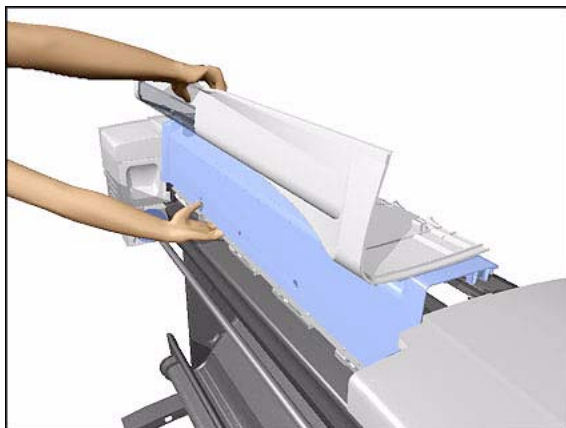

3. Lift up complete assembly (Window and Top Cover) and remove from Printer.

Media Deflectors

Removal

WARNING

Switch off the printer and remove the power cord.

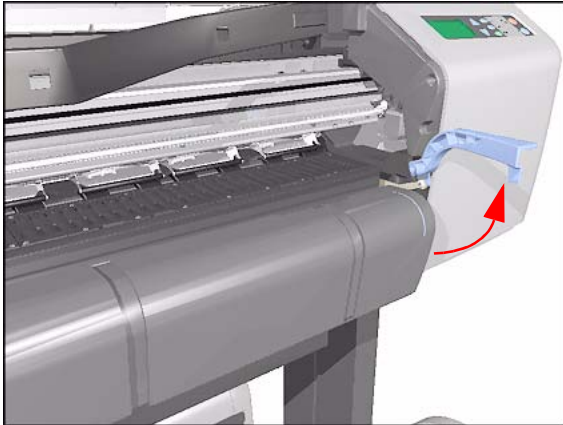

1. Make sure the Media Lever is in the UP Position.

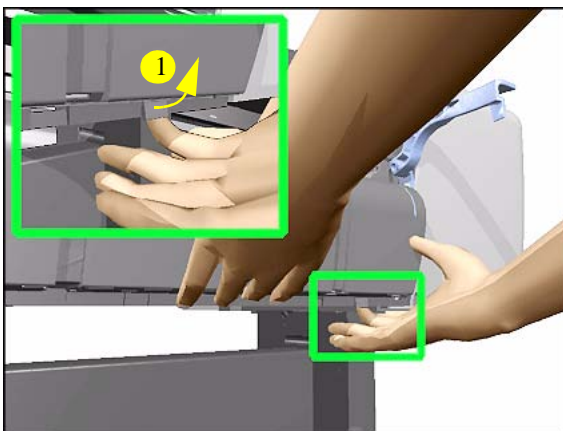

2. Lift tab up and slide Right Deflector to the **left** and lift up.

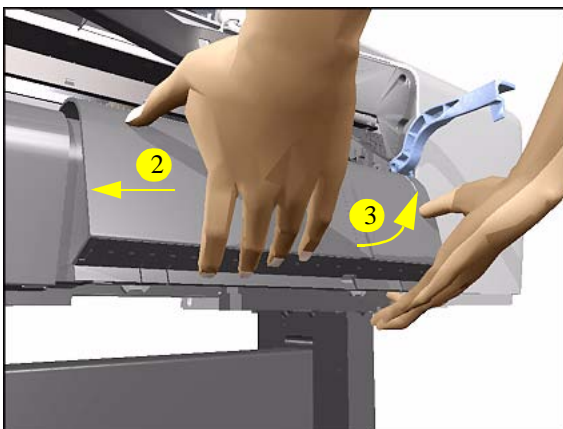

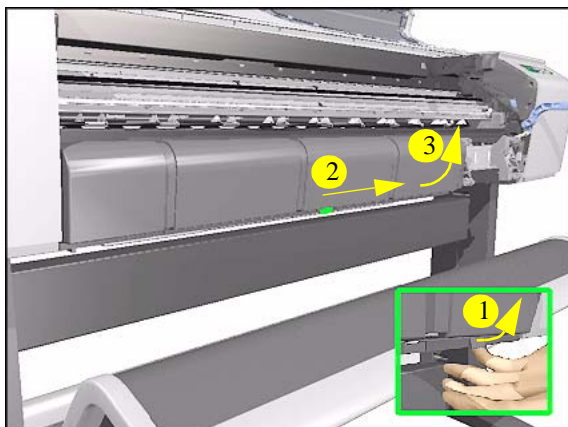

3. Lift tab up and slide Middle Deflector to the **right** and lift up.

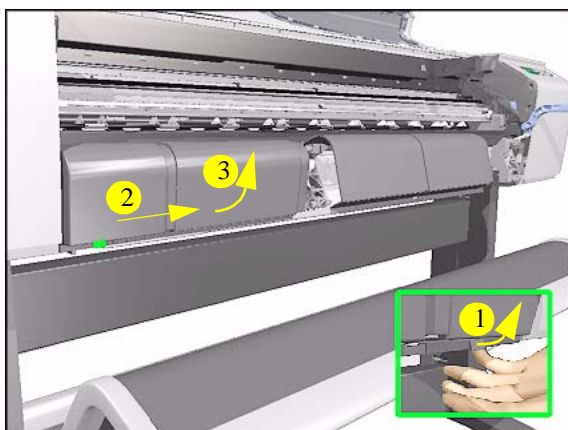

4. Lift tab up and slide Left Deflector to the **right** and lift up.

Left End Roll-Feed

Removal

WARNING

Switch off the printer and remove the power cord.

NOTE

Refer to the table on Page 8-4 for information on screw types.

1. Remove the Left Hand Cover - Refer to Page 8-5
2. Remove the Spindle.
3. Remove 1 T-20 screw (**Type F**) from the Left Hand Roll-Feed (located on the inside next to the Electronics Module).

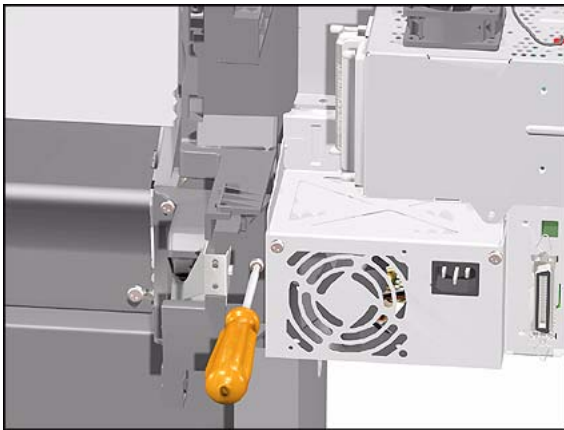

4. Remove 2 T-20 screws (**Type F**) from the Left End Roll-Feed.

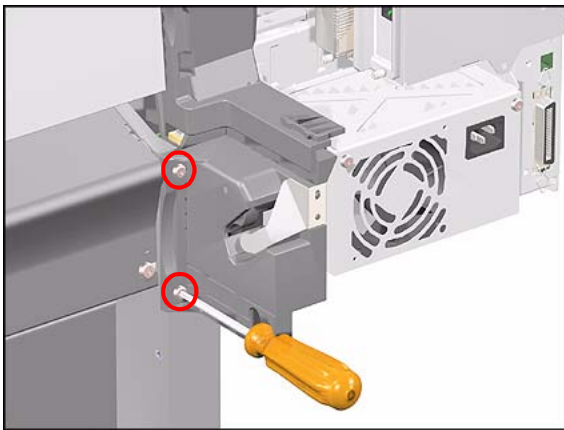

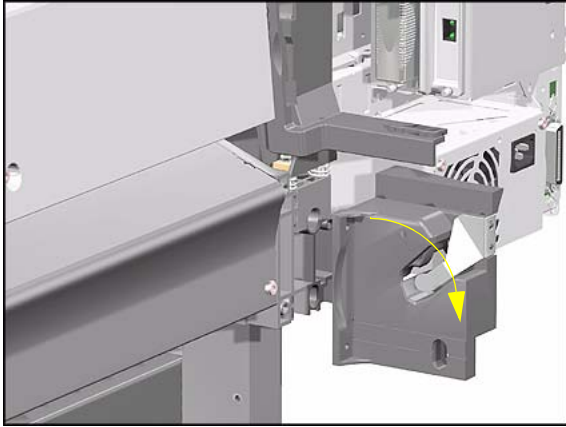

5. Move Left End Roll-Feed down and remove from Printer.

Right End Roll-Feed

Removal

WARNING Switch off the printer and remove the power cord.

NOTE Refer to the table on Page 8-4 for information on screw types.

1. Remove the Right Hand Cover - Refer to Page 8-7.
2. Remove the Spindle.
3. Remove 1 T-20 screw (**Type F**) from the Right Hand Roll-Feed.

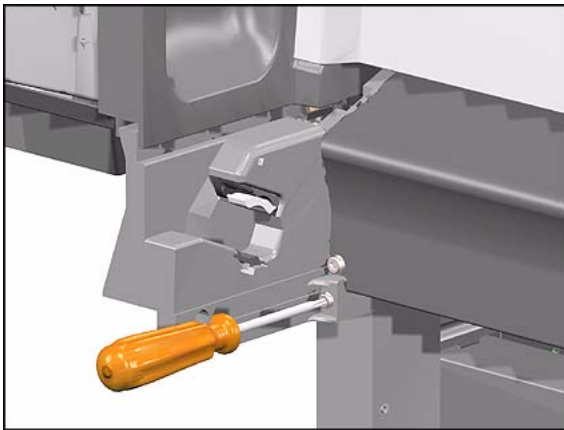

4. Remove 2 T-20 screws (**Type F**) from the Right Hand Roll-Feed (located on the inside).

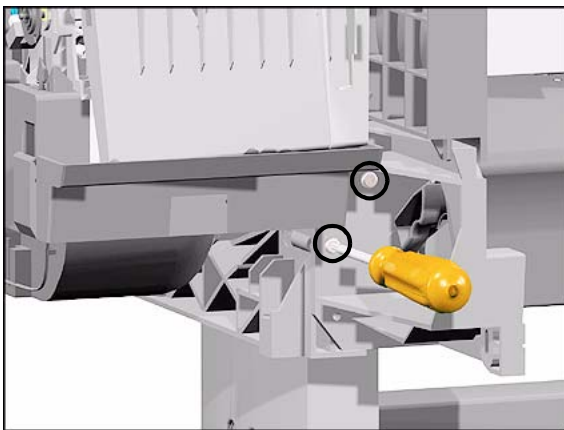

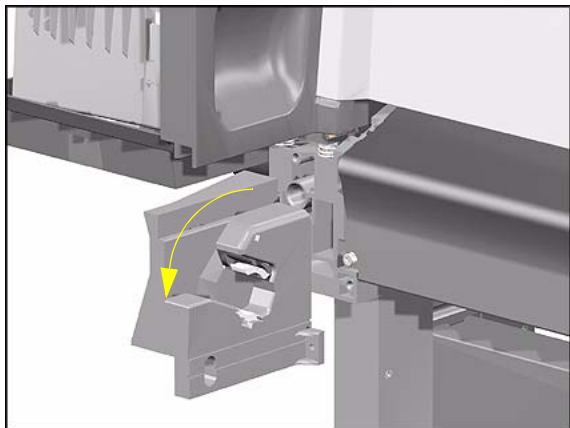

5. Remove Right Hand Roll-Feed.

Back Platen

Removal

WARNING Switch off the printer and remove the power cord.

NOTE Refer to the table on Page 8-4 for information on screw types.

1. Remove the Spindle.
2. Make sure the Media Lever is in the UP Position.

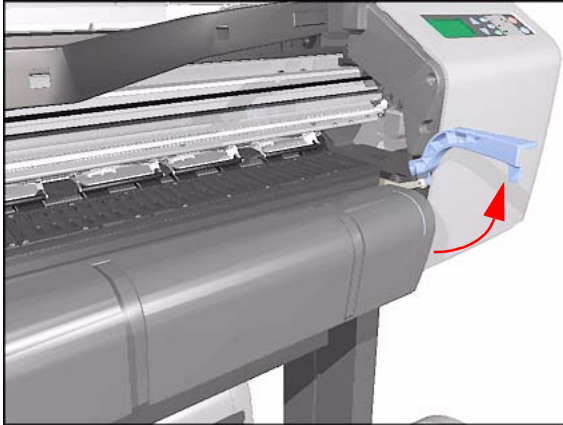

3. Unclip the Media Sensor Cover and remove from the Printer.

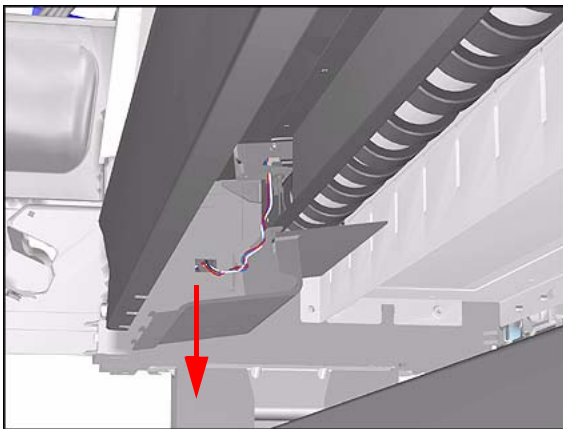

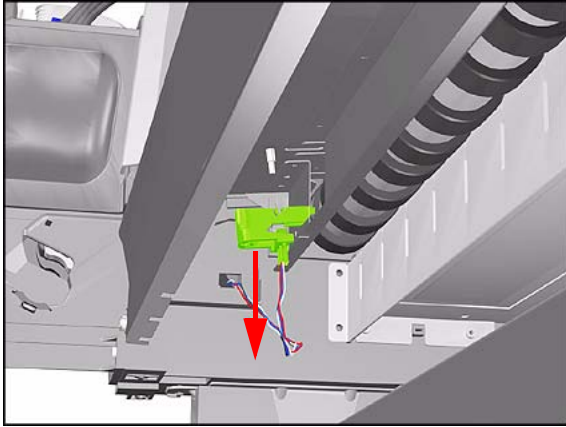

4. Unclip the Media Sensor from underneath the Back Platen.

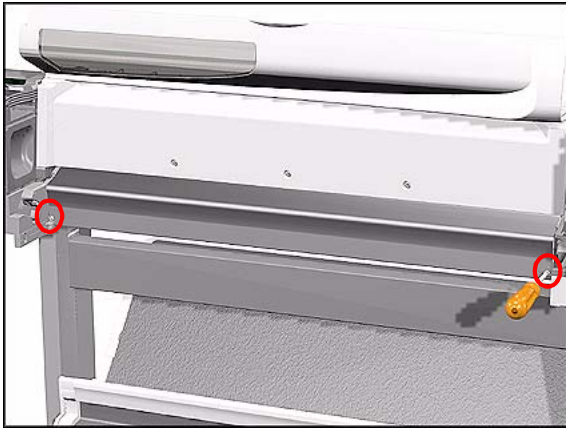

5. Remove 2 T-15 screws (**Type E**) from the Back Platen.

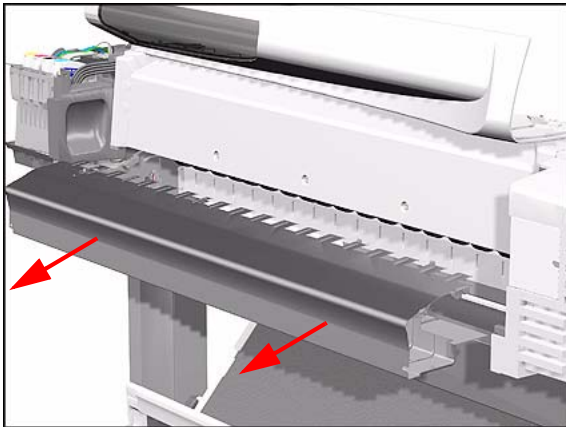

6. Remove the Back Platen by pulling it evenly towards you.

NOTE Make sure that the Media Sensor is not attached to the Back Platen to prevent pulling the cable and breaking the sensor.

Media Sensor

Removal

WARNING

Switch off the printer and remove the power cord.

1. Remove the Right Hand Cover - Refer to Page 8-7.
2. Remove the Spindle.
3. Disconnect the Media Sensor Cable from the ISS PCA.

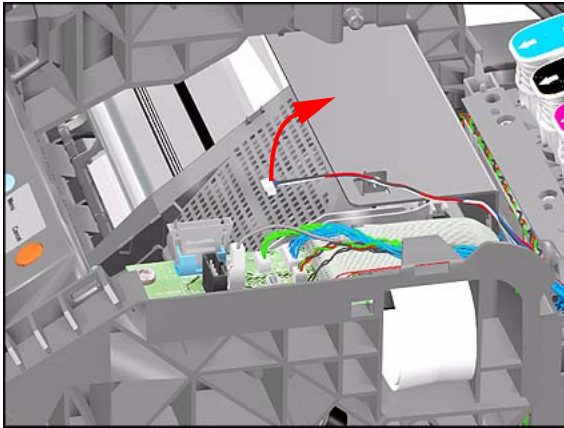

4. Unclip the Media Sensor Cover and remove from the Printer.

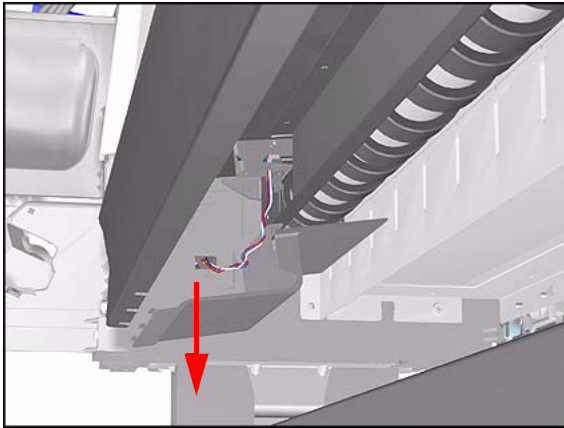

5. Unclip the Media Sensor from underneath the Back Platen. Route the Media Sensor cable out where necessary and remove the Media Sensor.

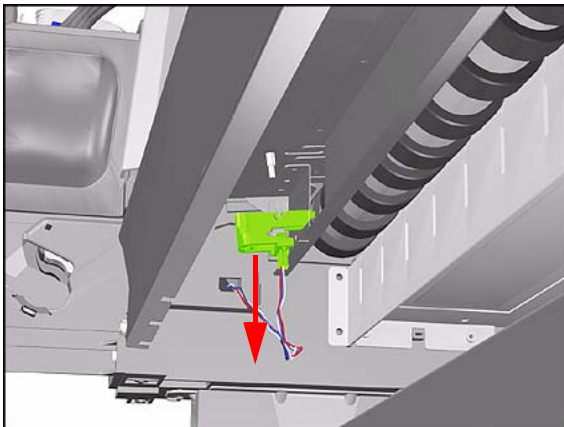

Formatter

Removal

WARNING Switch off the printer and remove the power cord.

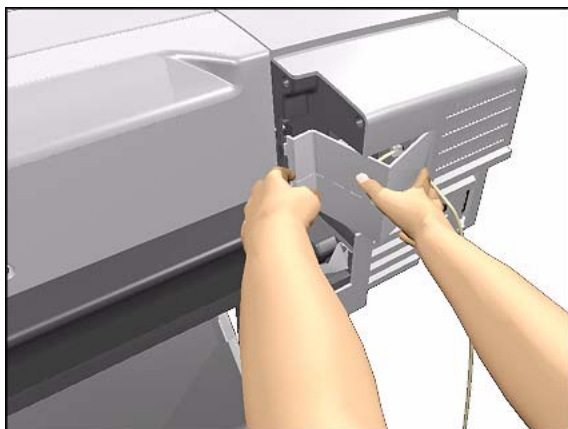

1. Remove the LAN Card Cover from the back of the Left Hand Cover.

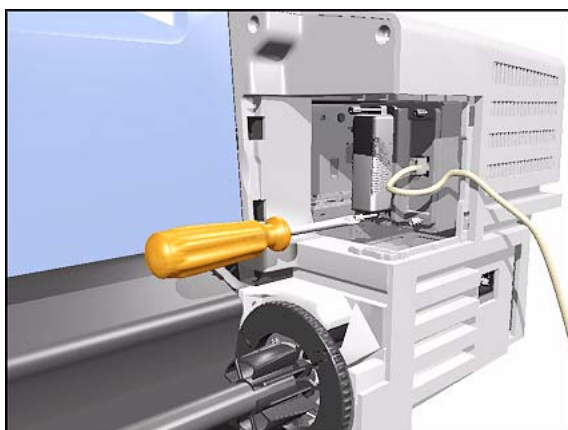

2. With a flat end screwdriver, unscrew the 2 screws that attach the Formatter to the Electronics.

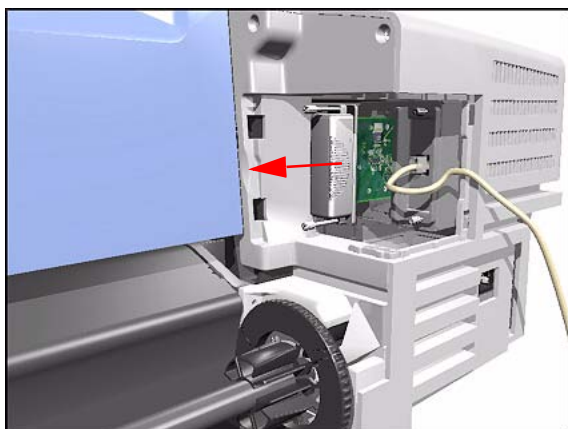

3. Remove the Formatter.

LAN Card

Removal

WARNING

Switch off the printer and remove the power cord.

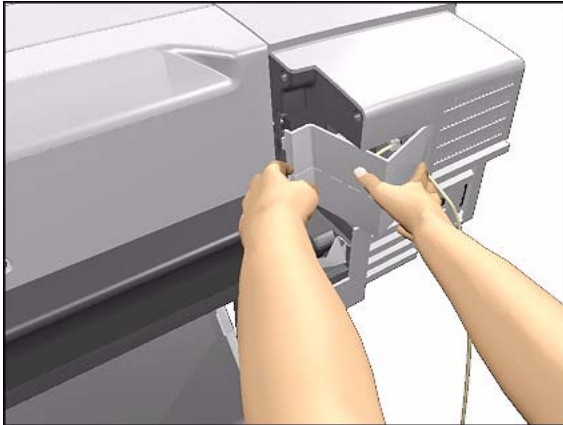

1. Remove the LAN Card Cover from the back of the Left Hand Cover.

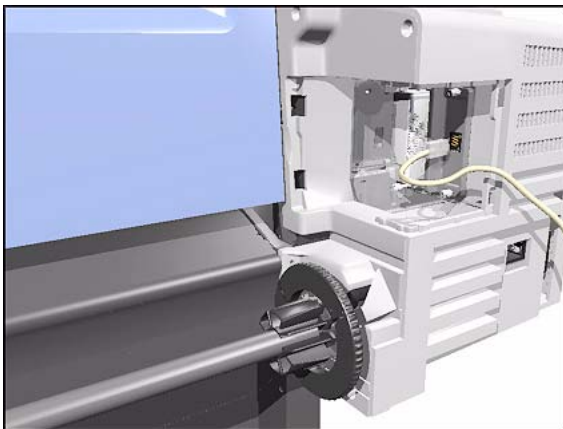

2. Disconnect the LAN Cable from the LAN Card

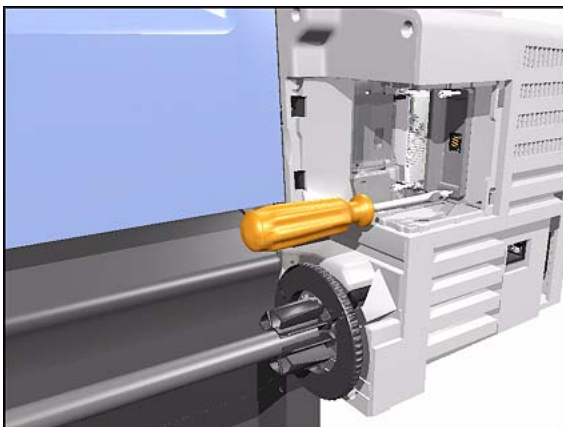

3. With a flat end screwdriver, unscrew the 2 screws that attach the LAN Card to the Electronics.

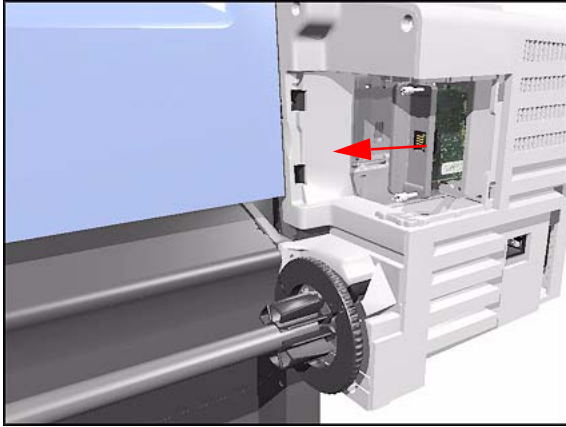

4. Remove the LAN Card from the Printer.

Spittoon

Removal

WARNING

Switch off the printer and remove the power cord.

1. Remove the Left Hand Cover - Refer to Page 8-5.
2. Release the cables that are attached to the Spittoon.

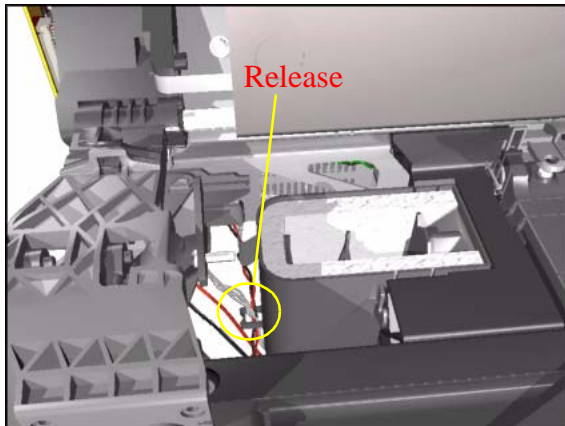

3. Press in the 2 clips to release the Spittoon.

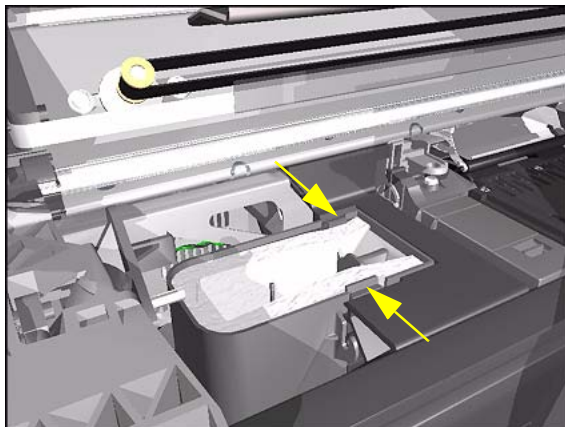

4. Lift up the Spittoon and remove from the Printer.

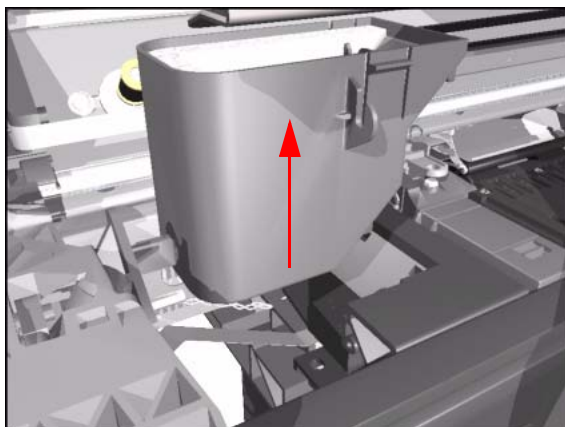

Electronics Module

Removal

WARNING Switch off the printer and remove the power cord.

NOTE Refer to the table on Page 8-4 for information on screw types.

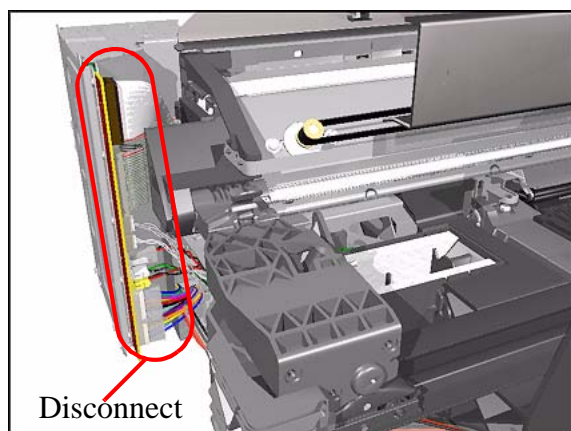

1. Remove the Left Hand Cover - Refer to Page 8-5.
2. Disconnect ALL the cables from the Electronics Module.



3. Remove 1 T-10 screw (**Type B**) from the top of the Electronics Module.

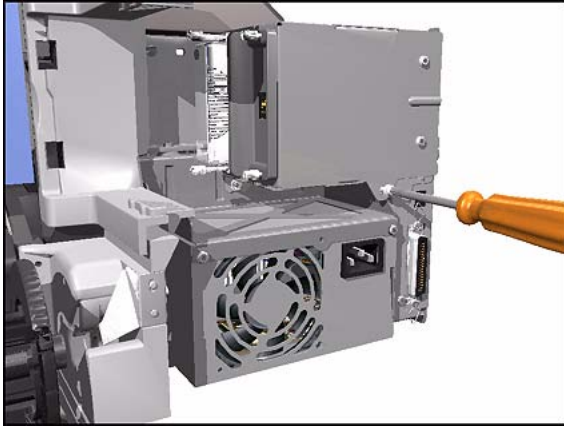

4. Remove 1 T-10 screw (**Type B**) from the back of the Electronics Module.

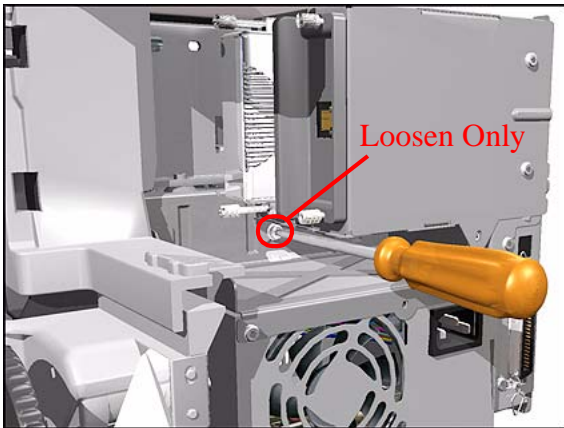

5. Loosen 1 T-10 screw (**Type B**) just below the Electronics Module.

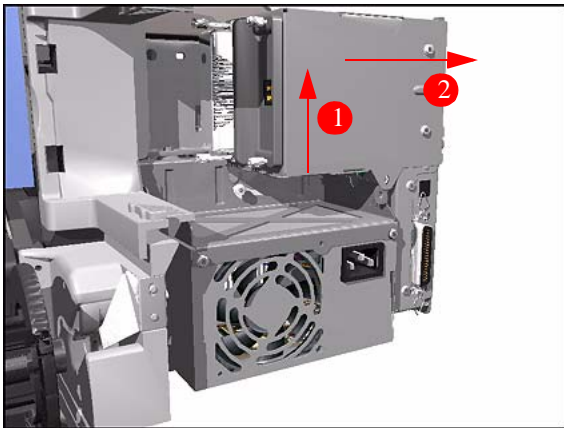

6. Lift the Electronics Module up and towards the right and remove from Printer.

Installing the Electronics Module

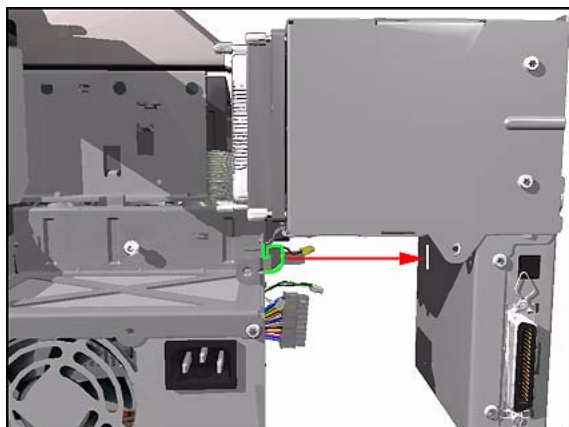

NOTE When installing the Electronics Module, make sure that you insert the tab on the Printer into the slot in the Electronics Module.

Power Supply

Removal

WARNING Switch off the printer and remove the power cord.

NOTE Refer to the table on Page 8-4 for information on screw types.

1. Remove the Left Hand Cover - Refer to Page 8-5.

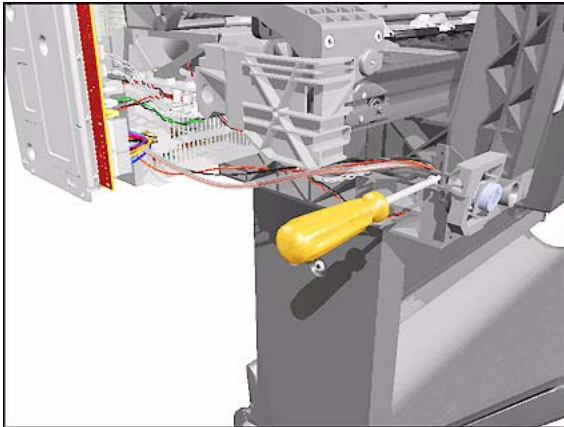

2. Remove 1 T-10 (**Type B**) screw from the Power Switch on the front of the Printer.

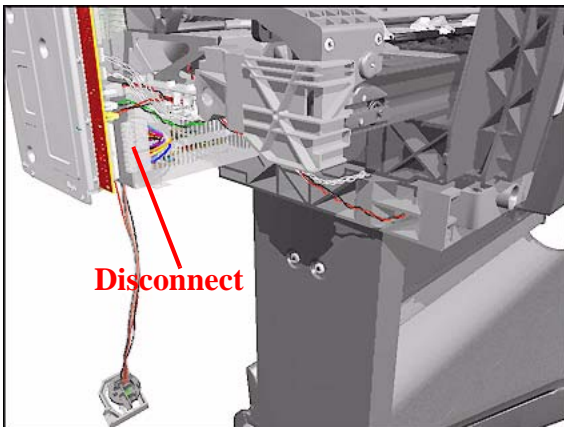

3. Disconnect the Power Supply Cable from the Electronics Module.

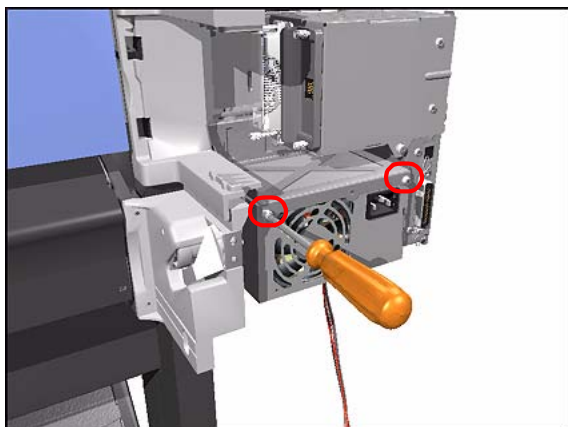

4. Remove 2 T-10 screws (**Type B**) that secure Power Supply to the Bracket.

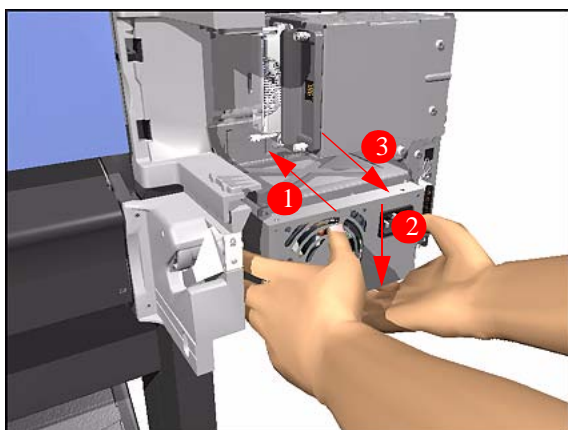

5. Remove the Power Supply as one assembly (Power Switch and Power Supply Unit).

Scan-Axis Motor Assembly

Removal

WARNING Switch off the printer and remove the power cord.

NOTE Refer to the table on Page 8-4 for information on screw types.

1. Remove the Left Hand Cover - Refer to Page 8-5.
2. Remove the Right Hand Cover - Refer to Page 8-7.
3. Remove the Power Supply - Refer to Page 8-27.
4. Disconnect the Scan-Axis Motor Cable from the Electronics Module.

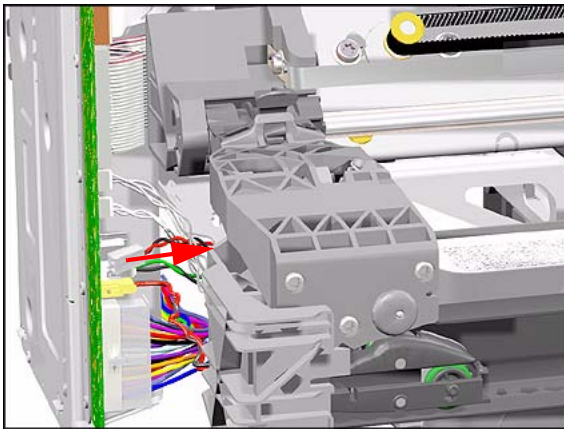

5. Release the tension from the right hand side of the Belt by pulling the Tensioner down and pushing it towards you to lock it into position.

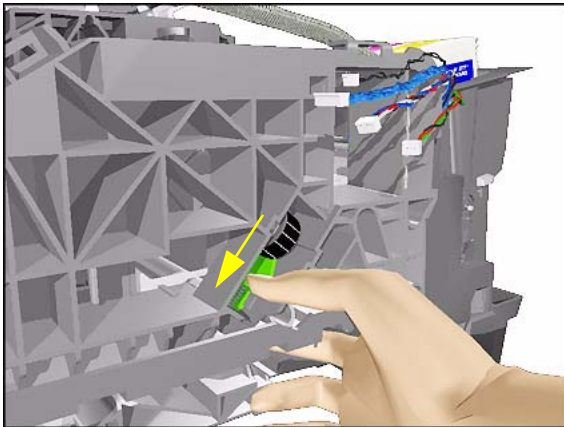

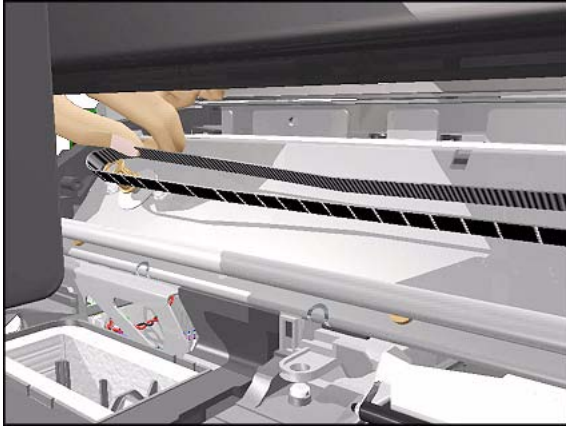

6. Remove the left hand side of the Belt from the Scan-Axis Motor.

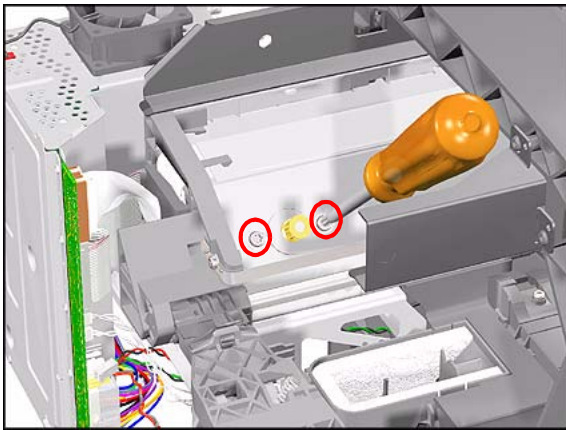

7. Remove 2 T-20 screws (**Type C**) from the Scan-Axis Motor.

NOTE Make sure that you keep hold of the Scan-Axis Motor when removing the screws, otherwise the Motor could fall and be damaged.

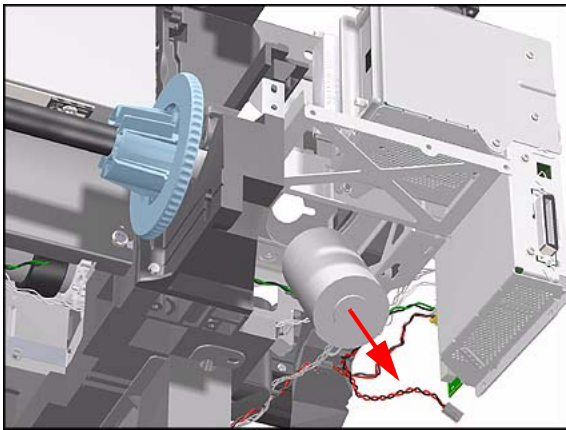

8. Remove the Scan-Axis Motor.

Installing the Scan-Axis Motor

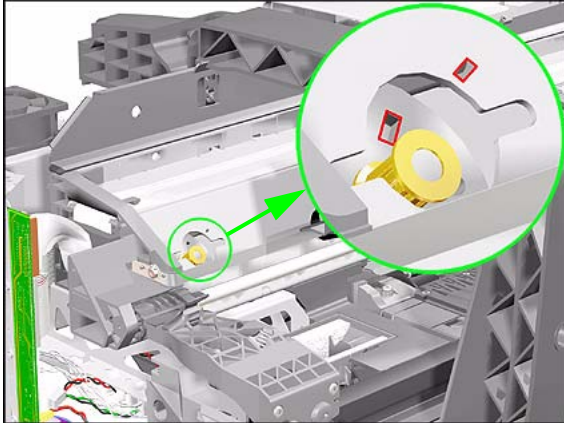

NOTE

When installing the Scan-Axis Motor, make sure that you insert the notch in the Printer into the slot in the Scan-Axis Motor.

Cutter Assembly

Removal

WARNING Switch off the printer and remove the power cord.

1. Select the "Change Cutter" option from the Front Panel Menu.
2. Open the Window.

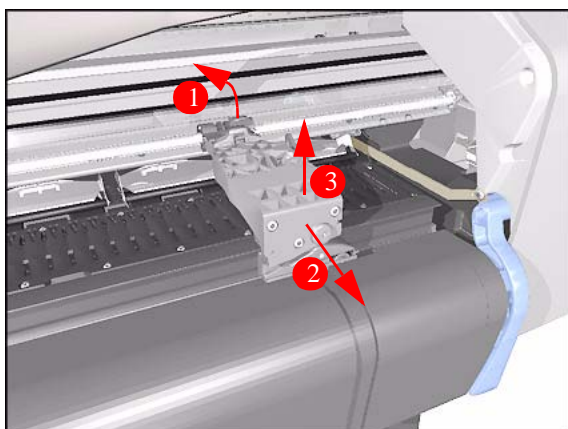
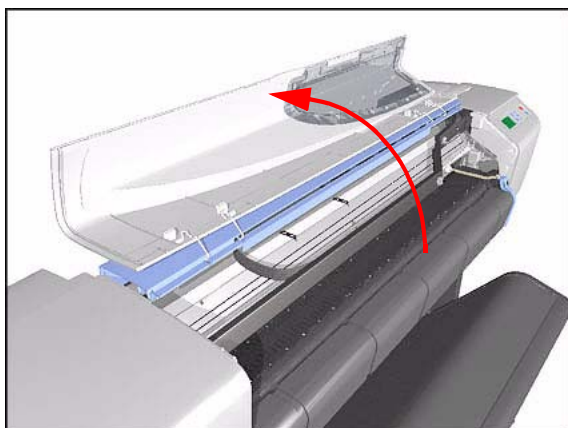

3. Lift Tab UP and pull out the Cutter Assembly.

Left Encoder Holder

Removal

WARNING

Switch off the printer and remove the power cord.

NOTE

Refer to the table on Page 8-4 for information on screw types.

1. Remove the Left Hand Cover - Refer to Page 8-5.
2. Remove 1 T-15 screw (**Type E**) from the Left Encoder Holder (attaches the Encoder Strip to the Holder).

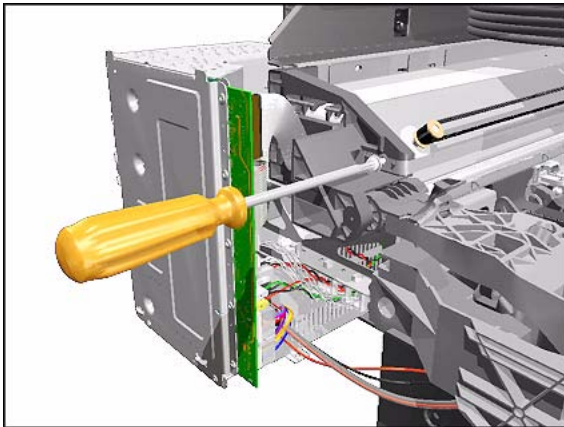

3. Release the Encoder Strip from the left hand side.

NOTE

The Encoder Strip is sharp so be careful when touching it.

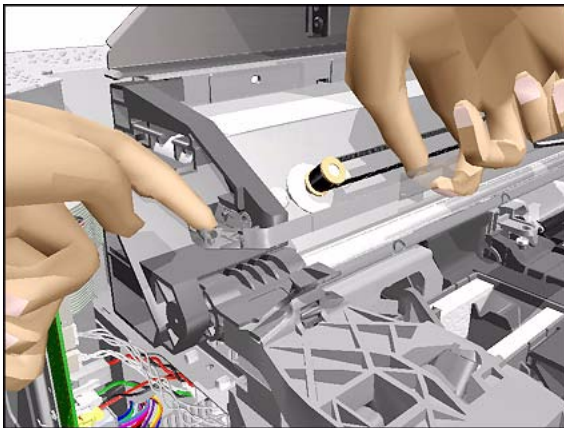

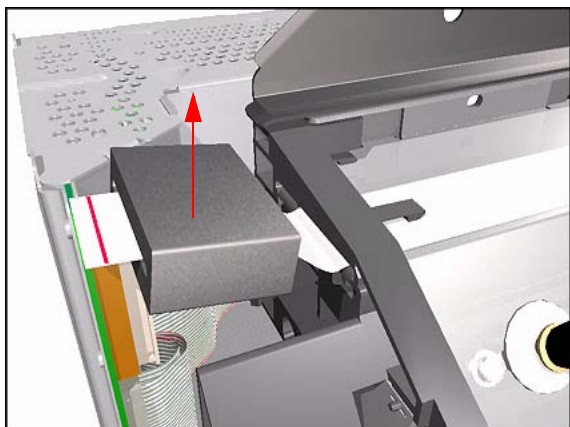

4. Disconnect the Trailing Cable and unclip the Ferrite and remove.

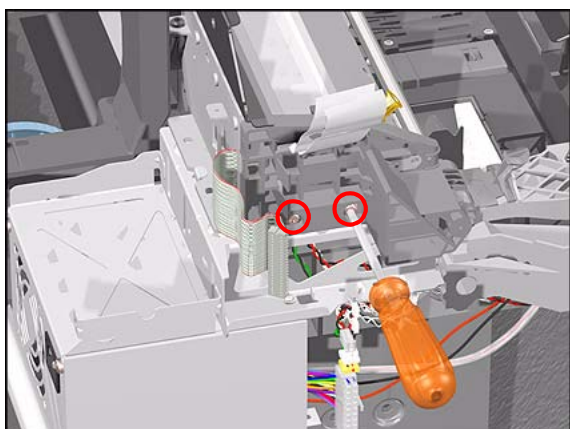

5. Remove the Electronics Module - Refer to Page 8-24.
6. Remove 2 T-20 screws (**Type A**) from the Left Encoder Holder.

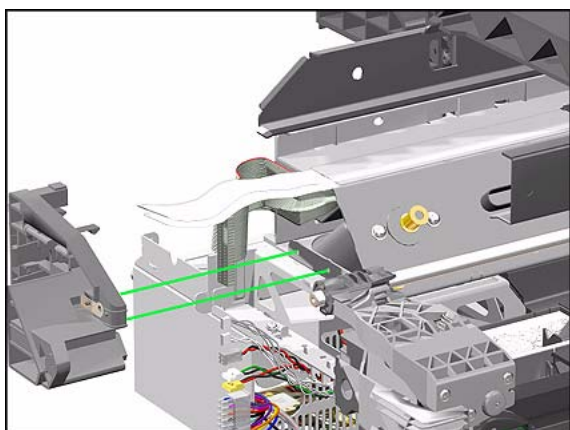

7. Remove the Left Encoder Holder, making sure that you first unclip both the Trailing Cable and the Interconnect Cable.

Cutter Bushing

Removal

WARNING

Switch off the printer and remove the power cord.

1. Remove the Left Hand Cover - Refer to Page 8-5.
2. Remove the Electronics Module - Refer to Page 8-24.
3. Remove the Cutter Assembly - Refer to Page 8-32.
4. Remove the Left Encoder Holder - Refer to Page 8-33.
5. Slide the Cutter Bushing to the Left and remove from the Printer.

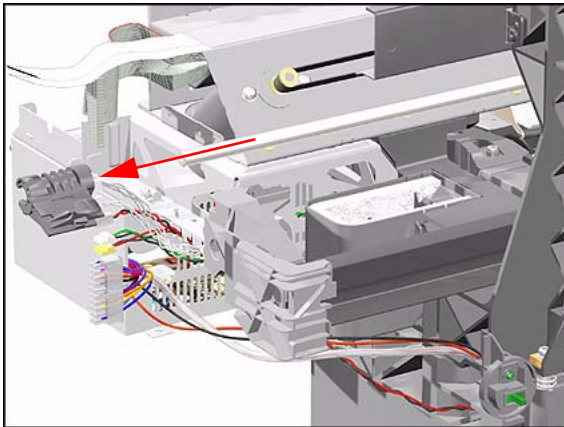

Cutter Guide Bracket

Removal

WARNING Switch off the printer and remove the power cord.

NOTE Refer to the table on Page 8-4 for information on screw types.

1. Remove the Left Hand Cover - Refer to Page 8-5.
2. Remove the Cutter from its position.

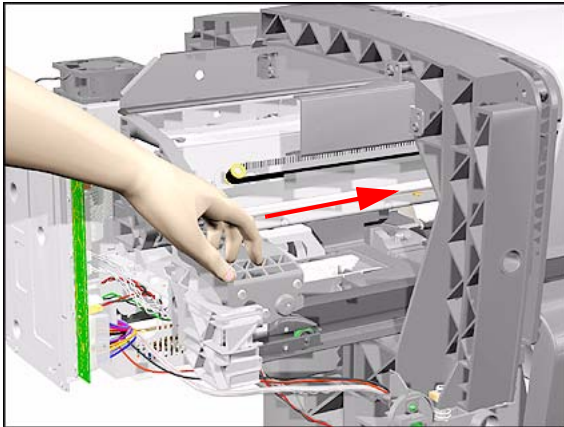

3. Remove the Vacuum Fan Cable from the Cutter Guide Bracket.

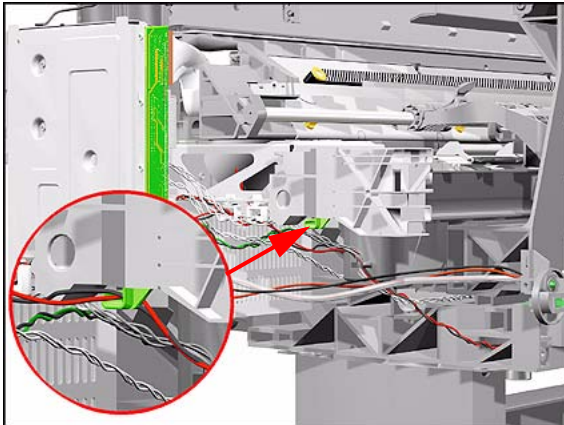

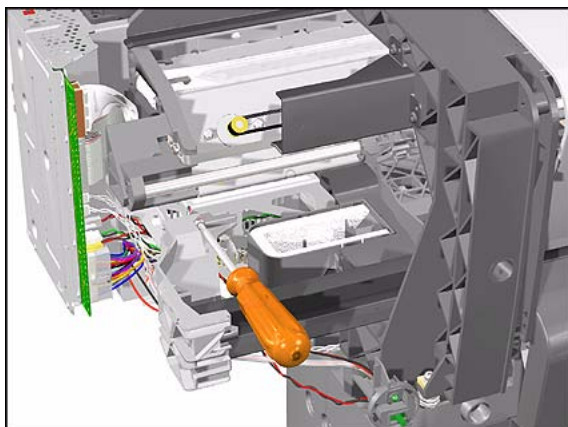

4. Remove 1 T-10 screw (**Type B**) from the Cutter Guide Bracket.

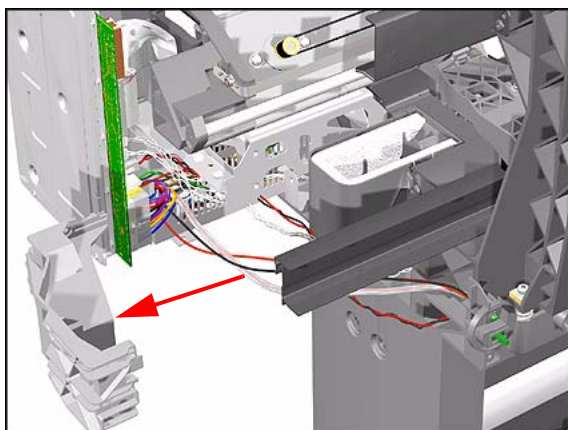

5. Slide the Cutter Guide Bracket out of the Printer.

Drive Roller Encoder Sensor

Removal

WARNING Switch off the printer and remove the power cord.

NOTE Refer to the table on Page 8-4 for information on screw types.

1. Remove the Left Hand Cover - Refer to Page 8-5.
2. Remove the Spittoon - Refer to Page 8-23.
3. Remove the Cutter Guide Bracket - Refer to Page 8-36.
4. Disconnect the Encoder Sensor Cable from the Electronics Module.

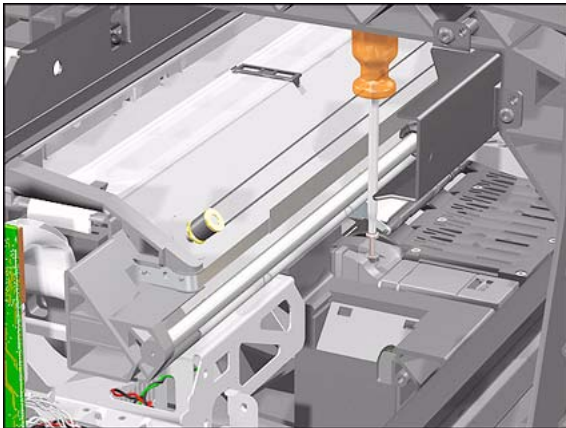
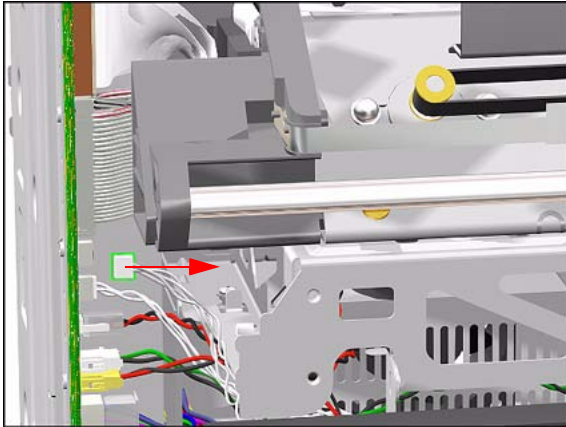

5. Remove 1 T-8 screw (**Type G**) from the Encoder Sensor Cover.

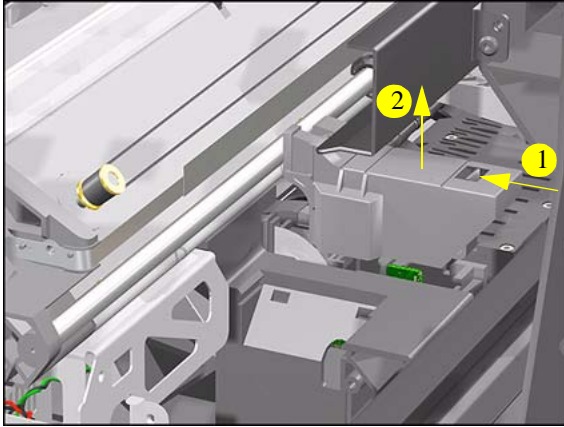

6. Depress the clip and remove the Encoder Sensor Cover.

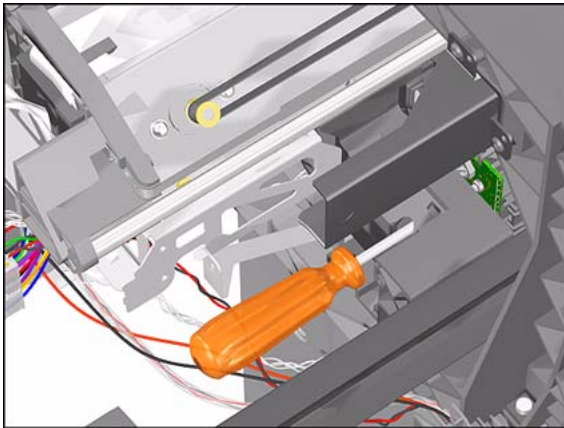

7. Remove 1 T-8 screw (**Type G**) from the Encoder Sensor.

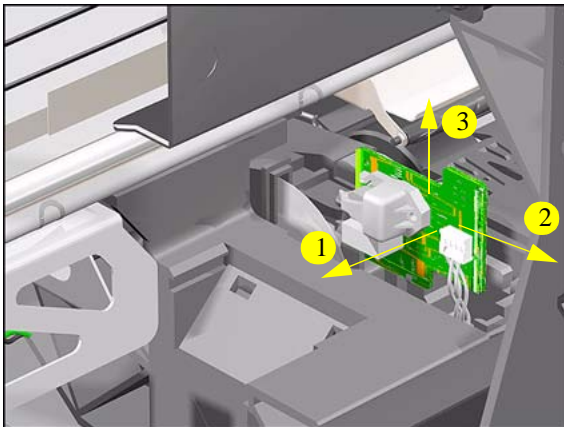

8. Move the Encoder Sensor to the left and remove (including the Encoder Sensor Cable).

Trailing Cable

Removal

NOTE Refer to the table on Page 8-4 for information on screw types.

1. Perform the Service Utility "Unlock Carriage" - Refer to Page 4-22.

NOTE Switch off the Printer after performing this Utility.

2. Remove the Left Hand Cover - Refer to Page 8-5.
3. Remove the Top Cover and Window - Refer to Page 8-10.
4. Manually move the carriage to the correct position to remove the Tubes Assembly from the Carriage.

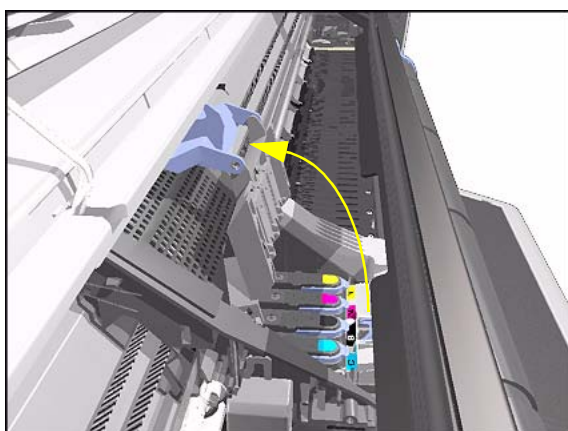
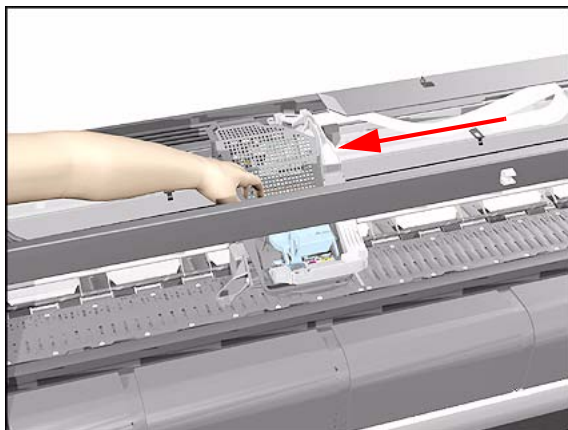

5. Release the latch and lift up the Carriage Cover.

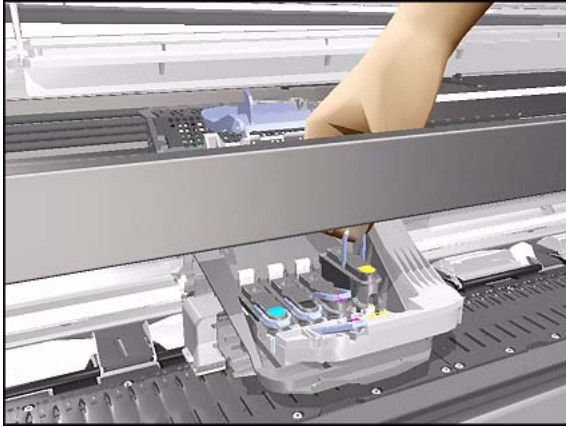

6. Remove all the Printheads.

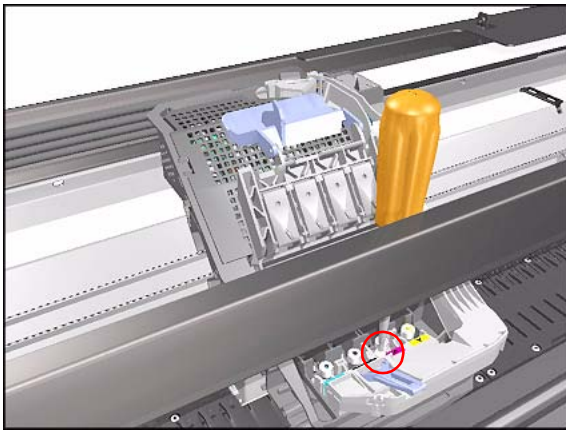

7. Loosen 1 T-8 screw that secures the Tubes to the Carriage.

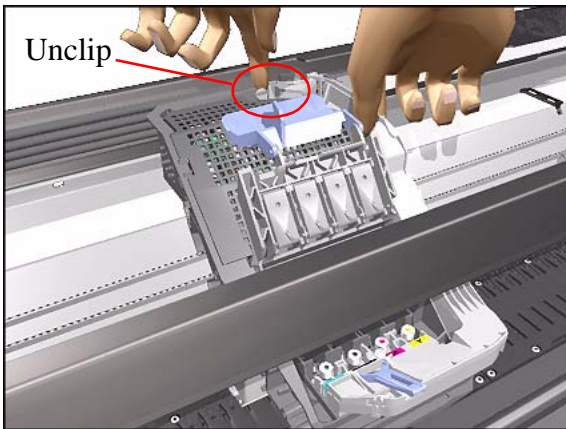

8. Unclip the Tubes from the Carriage and lift up.

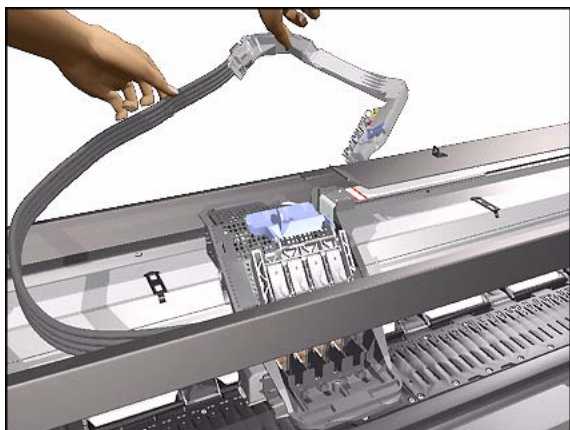

9. Move the Tubes Assembly clear from the Carriage Assembly.

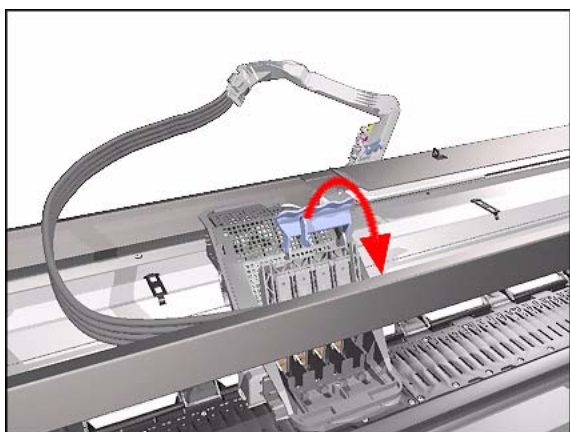

10. Close the Carriage Cover.

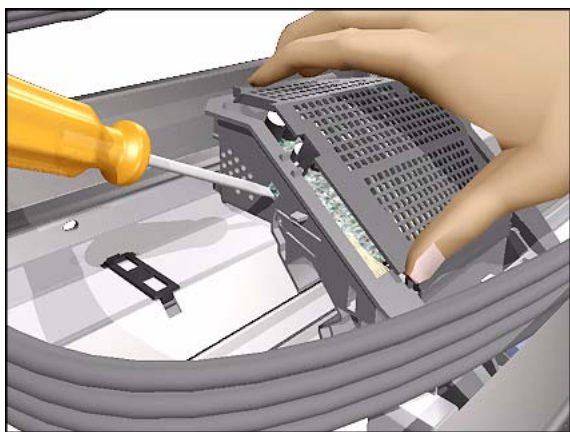

11. Unclip the Carriage Cover (clip located on the left hand side of the Carriage - use a screwdriver if necessary).

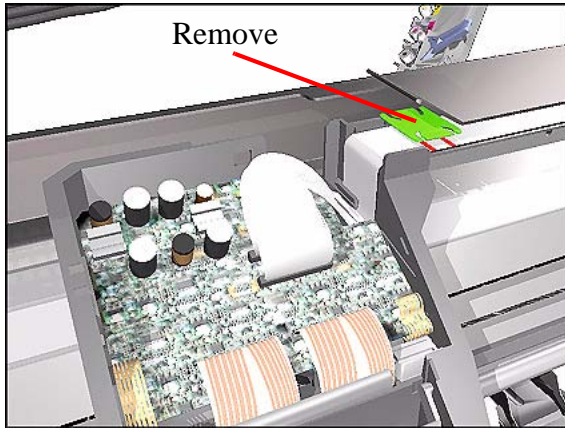

12. Remove the clip securing the Trailing Cable.

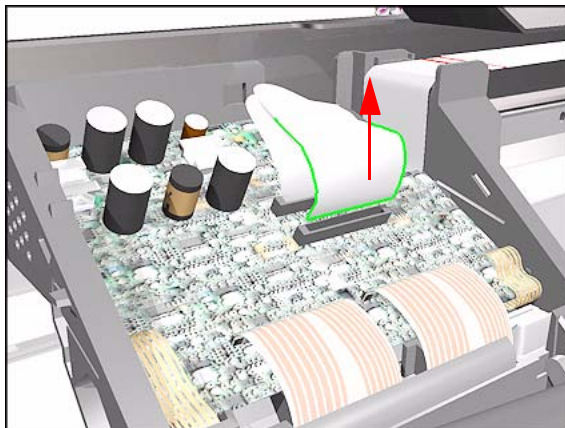

13. Disconnect the Trailing Cable from the Carriage Assembly.

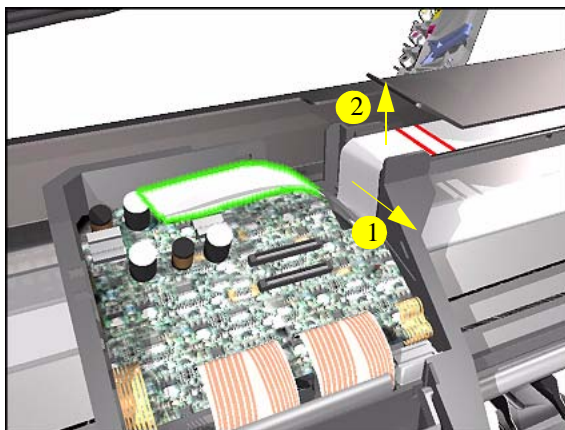

14. Slide the Trailing Cable out of the clip inside the Carriage Assembly and then lift up to free it from the Carriage.

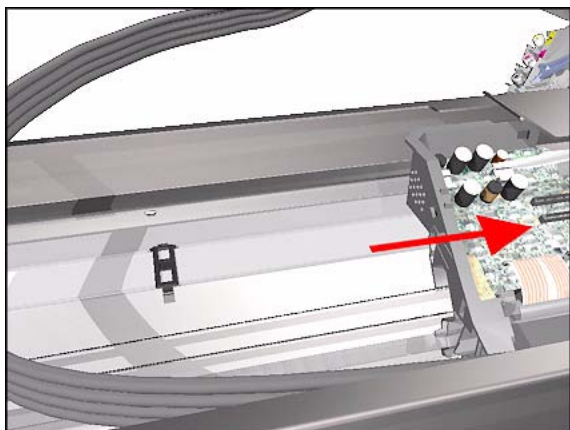

15. Move the Carriage Assembly to the right so that the Trailing Cable clips on the beam are visible.

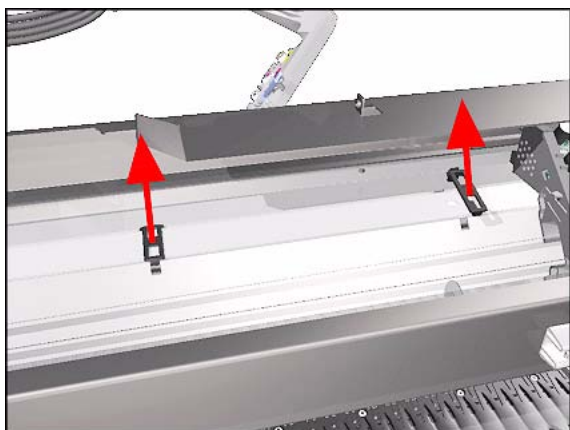

16. Release ALL the clips on the beam that secure the Trailing Cable.

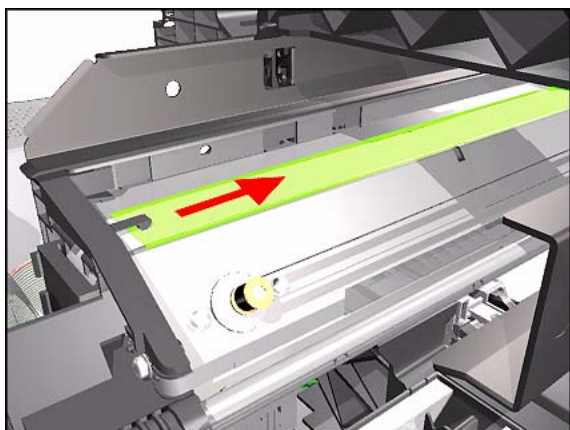

17. Slide the Plastic Holder, that kept the Trailing Cable flat, to the right to release it from the retaining clip.

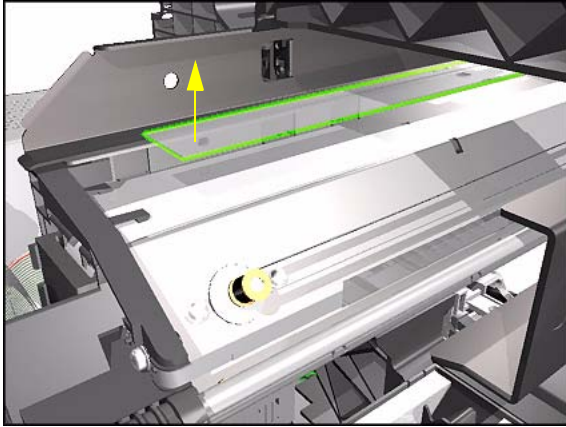

18. Remove the Plastic Holder from the Printer.

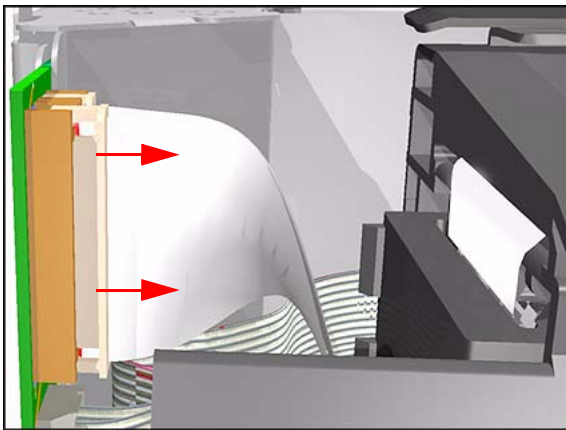

19. Release the Trailing Cable clips.

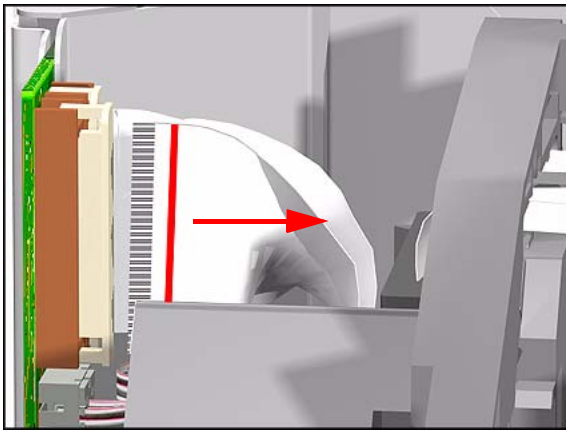

20. Disconnect the Trailing Cable from the Electronics Module.

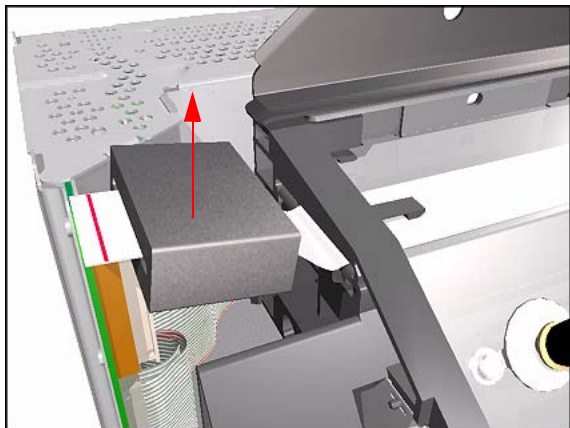

21. Unclip the Ferrite and remove.

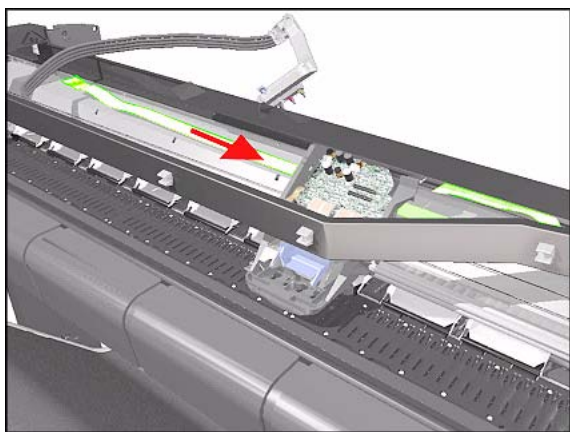

22. Slide the Trailing Cable through the Carriage Assembly and remove.

Installing the Trailing Cable

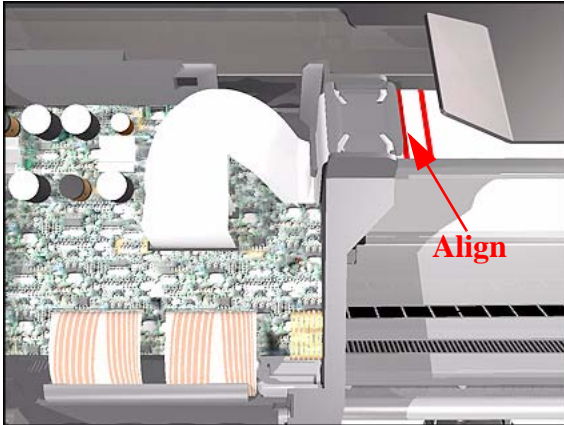

NOTE

When installing the Trailing Cable, make sure that you align the red lines on the Trailing Cable as shown in these drawings.

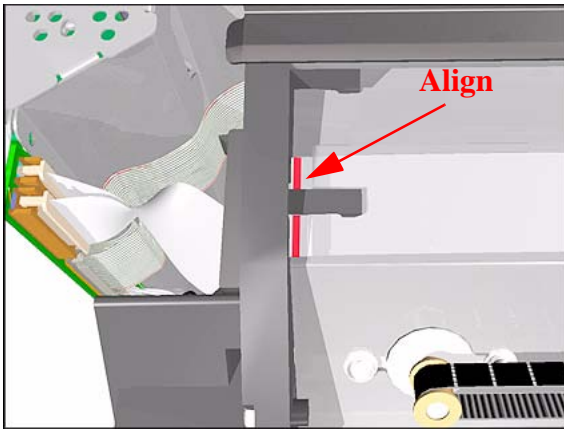

Ink Supply Station

Removal

WARNING Switch off the printer and remove the power cord.

NOTE Refer to the table on Page 8-4 for information on screw types.

1. Remove the Ink Cartridges.
2. Remove the Right Hand Cover - Refer to Page 8-7.
3. Disconnect the Ink Supply Station Cables (Connectors P2 and P4) from the Interconnect PCA.

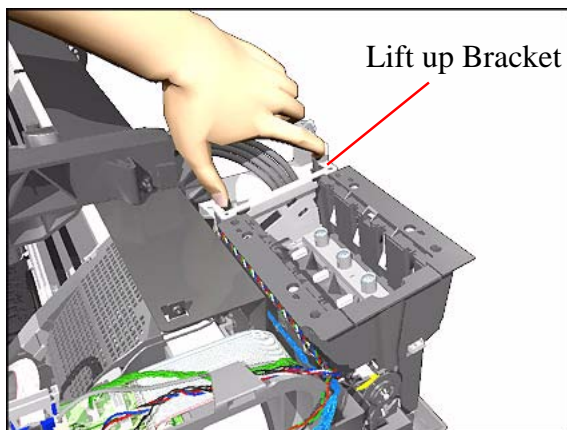
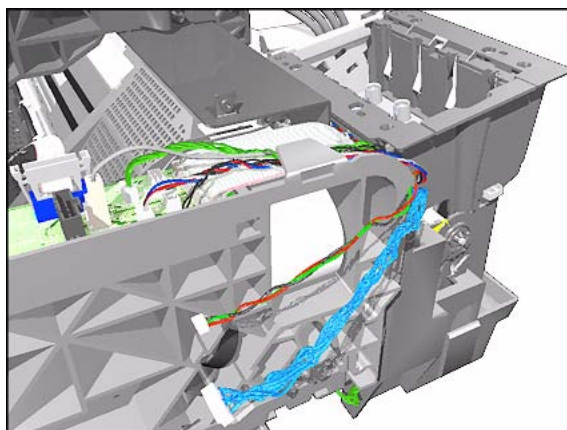

4. Release the Tubes Bracket from the Ink Supply Station by pushing the clips inwards and lifting up the Bracket.

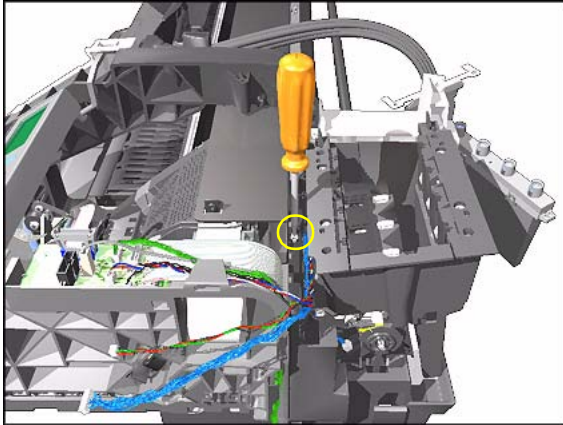

5. Remove 1 T-15 screw (**Type E**) from the top of the Assembly.

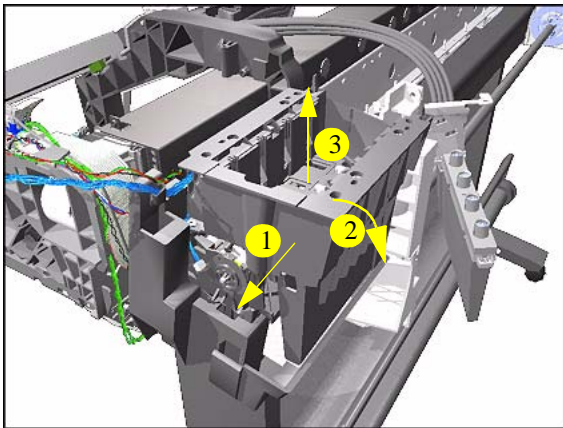

6. Remove the Ink Supply Station from the Printer.

NOTE The ISS is a complete Assembly that includes the Cartridge Holder (top) and Tray (bottom). The complete Assembly must be removed/installed together.

Interconnect PCA

Removal

WARNING Switch off the printer and remove the power cord.

NOTE Refer to the table on Page 8-4 for information on screw types.

1. Remove the Right Hand Cover - Refer to Page 8-7.
2. Disconnect all the cables connected to the Interconnect PCA.
3. Remove 1 T-15 screw (**Type E**) from the Interconnect PCA.

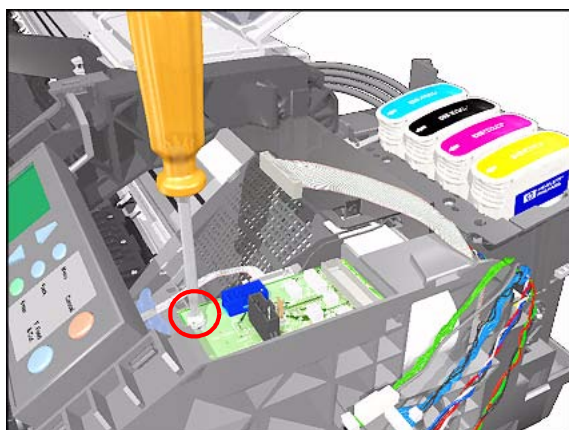
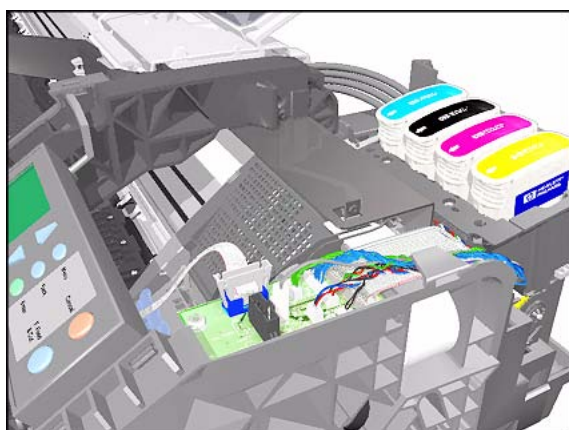

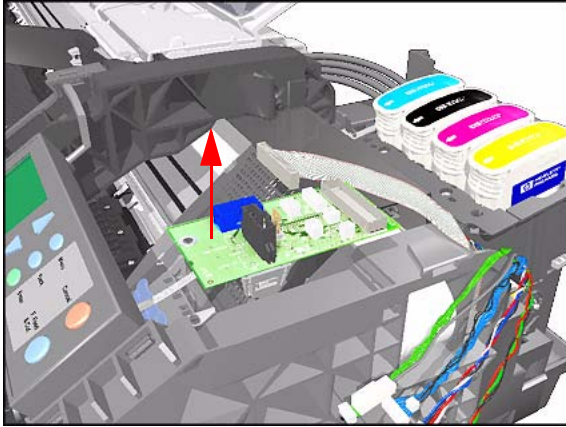

4. Lift the Interconnect PCA and remove.

Service Station and Aerosol Fan

Removal

NOTE

Refer to the table on Page 8-4 for information on screw types.

1. Perform the Service Utility "Unlock Carriage" - Refer to Page 4-22.

NOTE

Switch off the Printer after performing this Utility.

2. Remove the Right Hand Cover - Refer to Page 8-7.
3. Manually move the Carriage out of the Service Station.

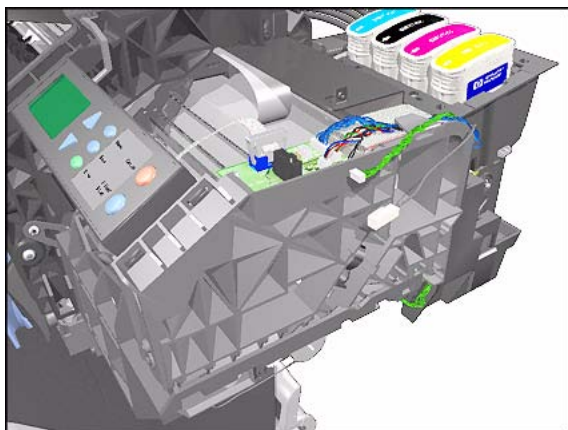

4. Disconnect the Service Station and Aerosol Fan Cables (connectors P5 and P9) from the Interconnect PCA.

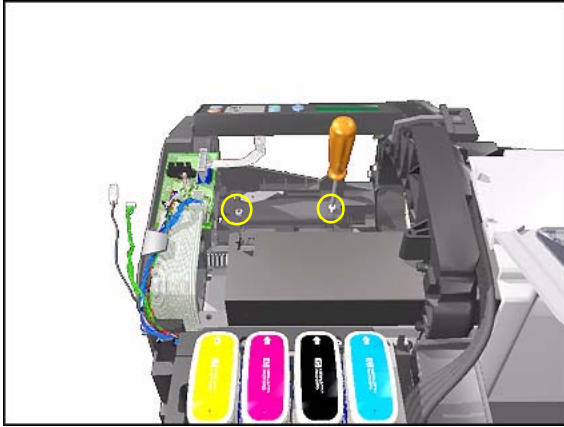

5. Remove 2 T-15 screws (**Type E**) from inside the Service Station.

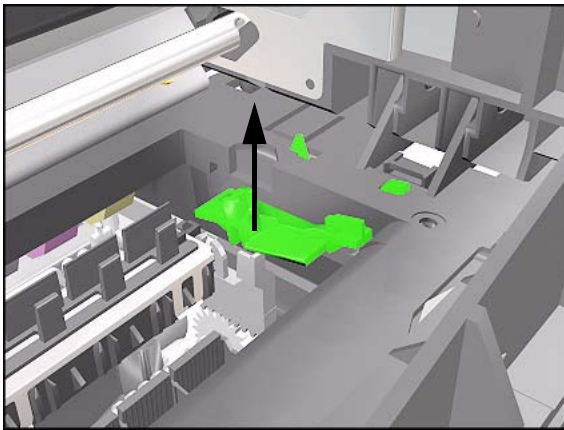

6. Make sure you lift the Carriage Lock before sliding out the Service Station out of the Printer.

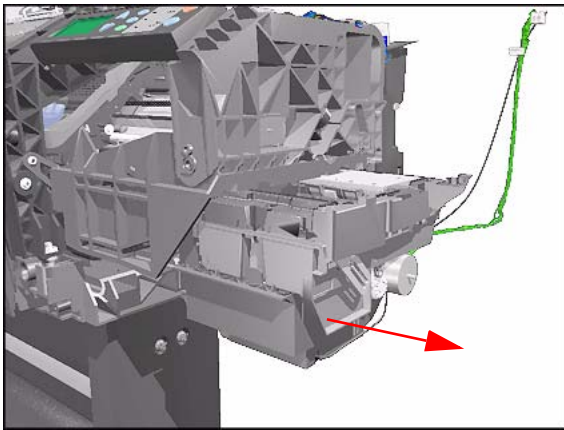

7. Slide the Assembly towards you (to the right) and remove.

Installing the Service Station/Aerosol Fan

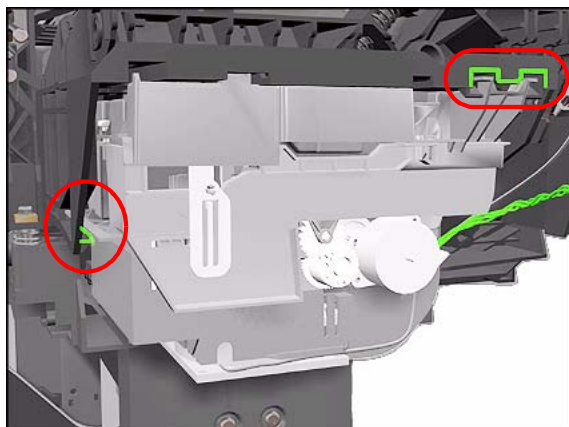

NOTE

When installing the Service Station, make sure that you line up the tabs on the Service Station with the structure of the Service Station Holder.

Cutter Guide

Removal

WARNING Switch off the printer and remove the power cord.

1. Remove the Cutter Assembly - Refer to Page 8-32.
2. Place your hands on the Cutter Guide (as shown in the drawing) and lift up.

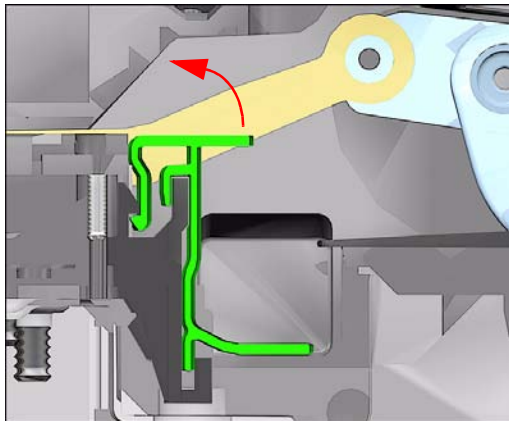
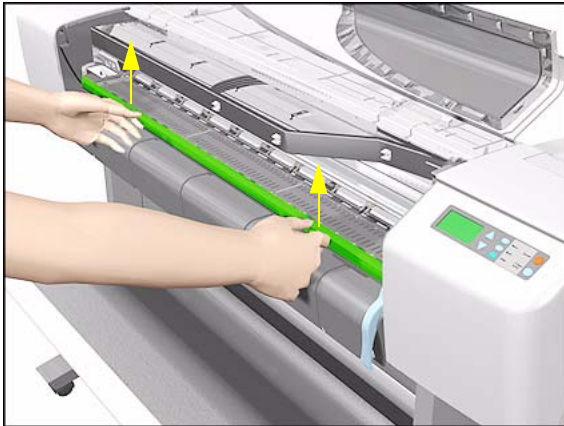

This is a cross-sectional view of the Printer showing how the Cutter Guide is seated.

3. Pull the Cutter Guide out to the right and remove from the Printer.



Print Platen

Removal

WARNING Switch off the printer and remove the power cord.

NOTE Refer to the table on Page 8-4 for information on screw types.

1. Remove the Cutter Assembly - Refer to Page 8-32.
2. Remove the Cutter Guide - Refer to Page 8-55.
3. Remove the following screws (Type G) from the Print Platen:
 - 24 Screws (T-8) for the 24" model.
 - 36 Screws (T-8) for the 42" model.

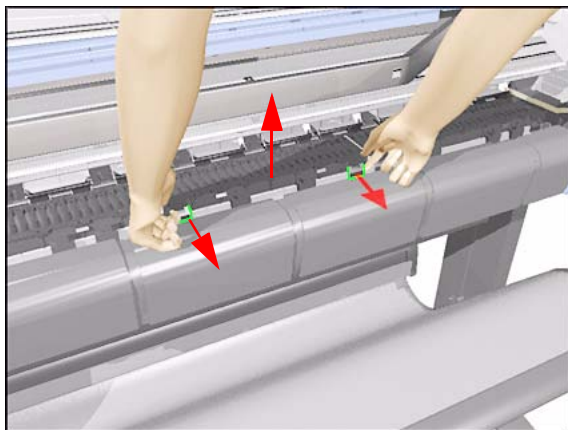
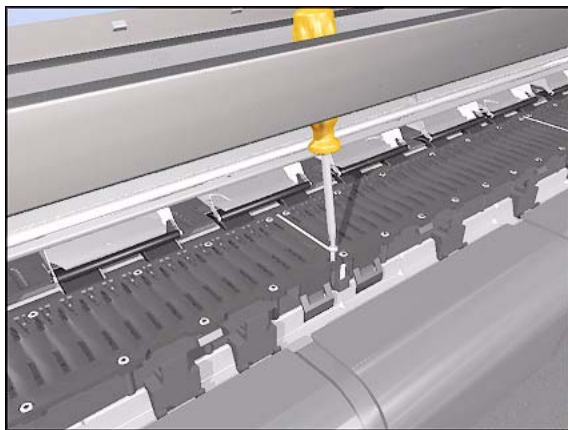

4. Pull the tabs out slightly and lift each piece of the Print Platen from the Printer.

NOTE The Print Platen is split into 2 pieces on the 24" model and into 3 pieces on the 42" model.

Service Station Holder

Removal

WARNING

Switch off the printer and remove the power cord.

NOTE

Refer to the table on Page 8-4 for information on screw types.

1. Remove the Left Hand Cover - Refer to Page 8-5.
2. Remove the Right Hand Cover - Refer to Page 8-7.
3. Remove the Right Hand Trim.
4. Remove the Front Panel Assembly - Refer to Page 8-9.
5. Remove the Interconnect PCA - Refer to Page 8-50.
6. Remove the Service Station - Refer to Page 8-52.
7. Remove the Fork Idler, Tensioner and Idler Pulley - Refer to Page 8-74.
8. Remove the Encoder Strip - Refer to Page 8-76.
9. Remove 1 T-15 screw (**Type E**) that secures the Service Station Holder to the sideplate.

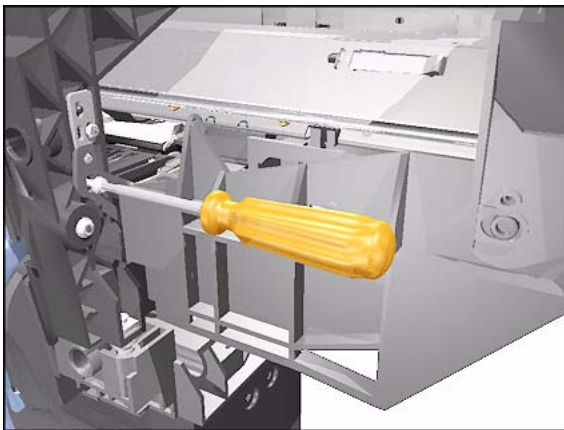

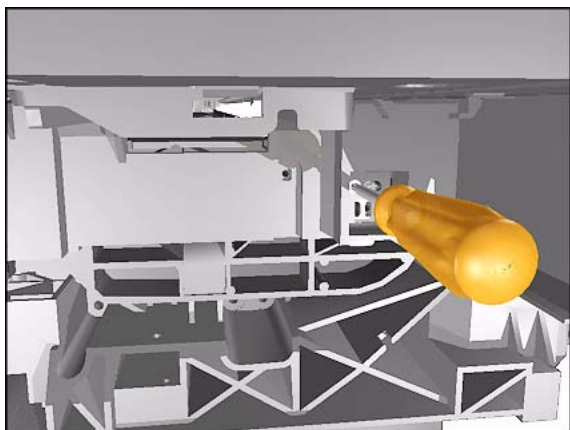

10. Remove 1 T-15 screw (**Type E**) that secures the Service Station Holder to the sideplate (located underneath the Service Station Holder).

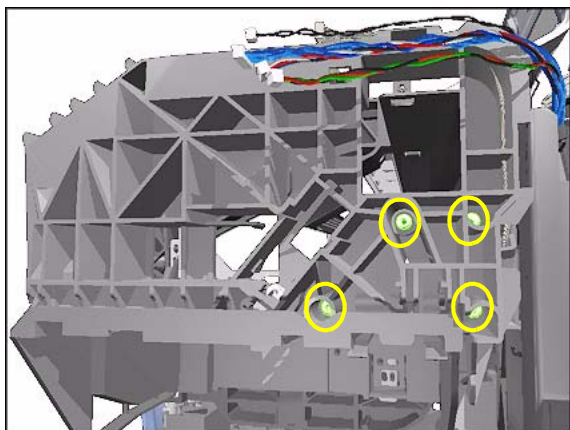

11. Remove 4 T-20 screws (**Type C**) that secure the Service Station Holder to the Printer Chassis.

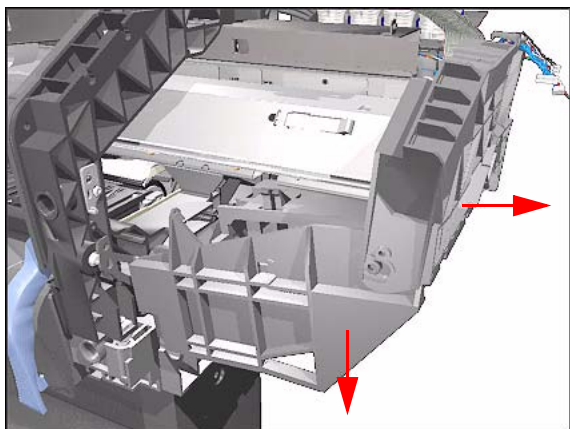

12. Remove the Service Station Holder.

Interconnect Cable

Removal

WARNING

Switch off the printer and remove the power cord.

1. Remove the Left Hand Cover - Refer to Page 8-5.
2. Remove the Right Hand Cover - Refer to Page 8-7.
3. Remove the Electronics Module - Refer to Page 8-24.
4. Remove the Left Encoder Holder - Refer to Page 8-33.
5. Remove the Service Station - Refer to Page 8-52.
6. Remove the Service Station Holder - Refer to Page 8-57.
7. Slide the Cable out of the Printer from the right hand side.

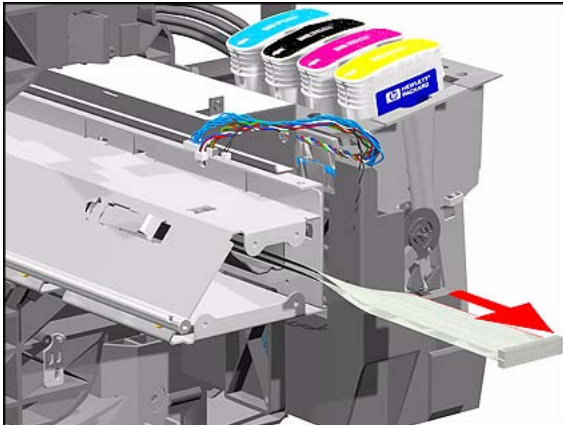

NOTE Make sure when removing the cable that it does NOT scratch against the edge of the beam.

NOTE Make sure that the Plastic Protector is NOT removed while removing the Cable.

Ink Supply Tubes

Removal

1. Perform the Service Utility "Change Ink Tubes" - Refer to Page 4-25.
2. Open the Window and locate the Carriage Assembly.

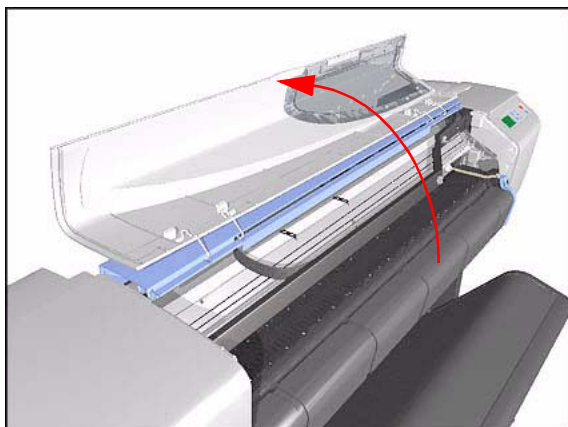

3. Release the latch and lift up the Carriage Cover.

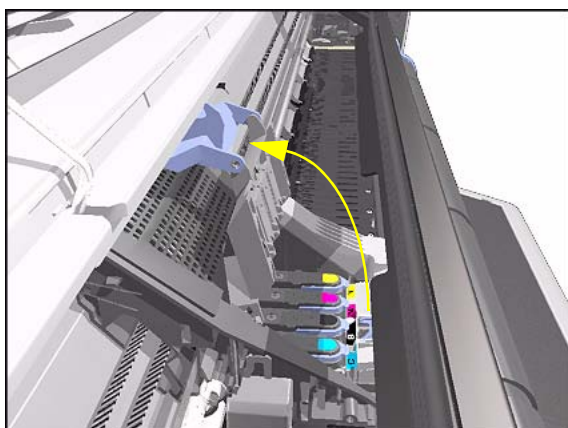

4. Remove all the Printheads.

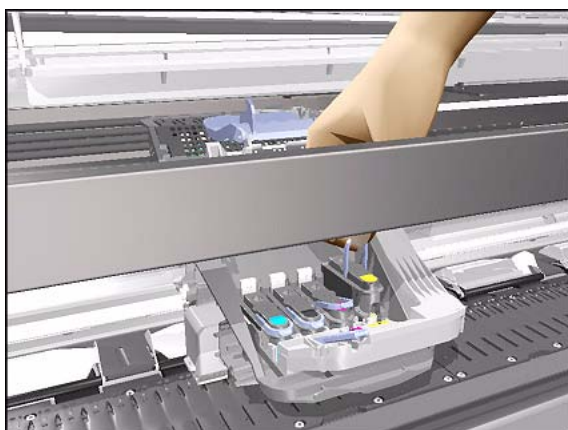



5. Open the Ink Cartridge Access Cover.



6. Remove all the Ink Cartridges.



7. Switch OFF the Printer and remove the power cord.

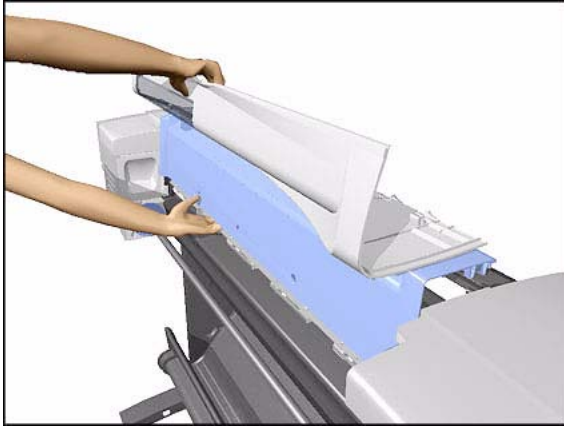

8. Remove the Top Cover and Window - Refer to Page 8-10.

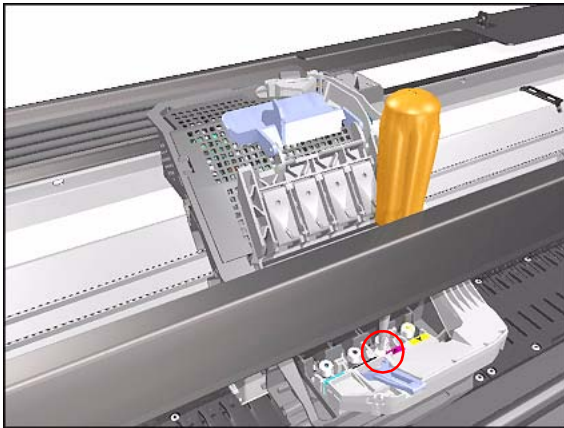

9. Loosen 1 T-8 screw that secures the Tubes to the Carriage.

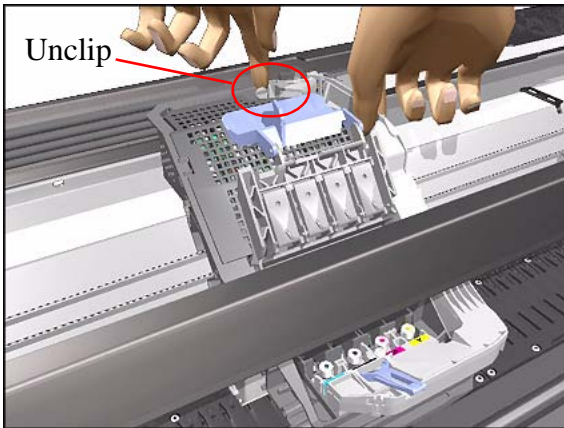

10. Unclip the Tubes from the Carriage and lift up.

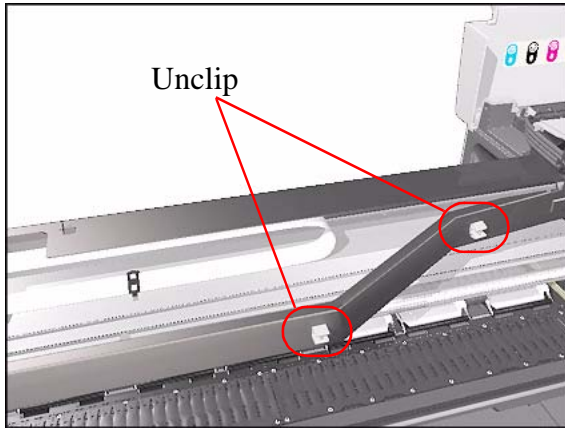

11. Unclip the tubes from the Tubes Guide.

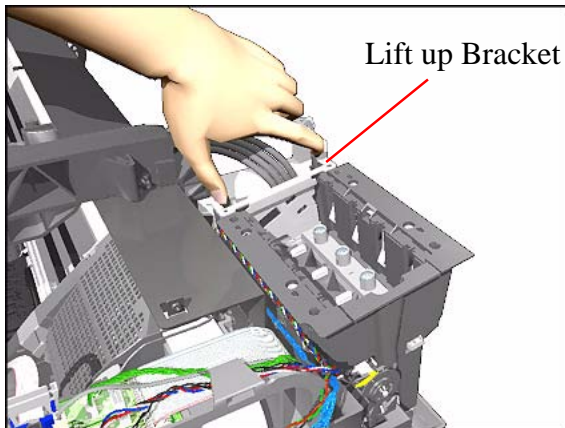

12. Release the Tubes Bracket from the Ink Supply Station by pushing the clips inwards and lifting up the Bracket.

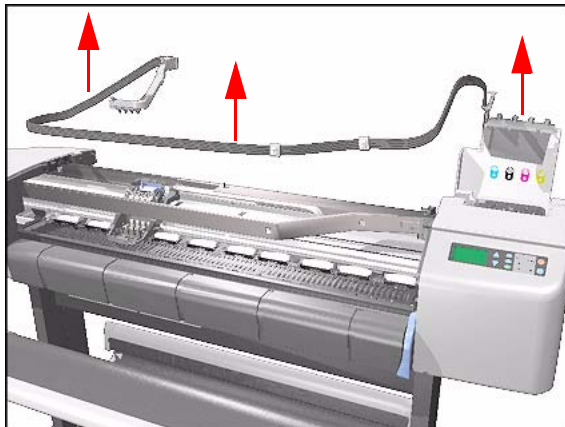

13. Remove the complete Ink Supply Tubes Assembly from the Printer.

Vacuum Fan

Removal

WARNING

Switch off the printer and remove the power cord.

1. Remove the Left Hand Cover - Refer to Page 8-5.
2. Remove ALL the Media Deflectors - Refer to Page 8-11.
3. Disconnect the Vacuum Fan Cable from the Electronics Module.

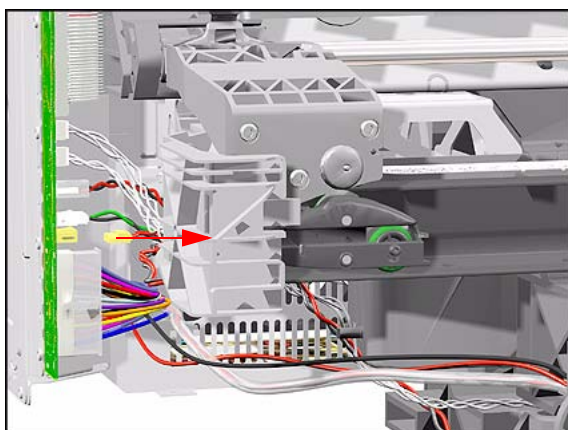

4. Remove the Vacuum Fan Cable from the Cutter Guide Bracket.

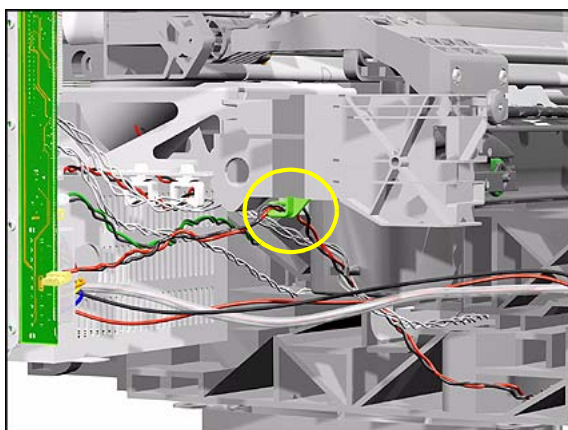

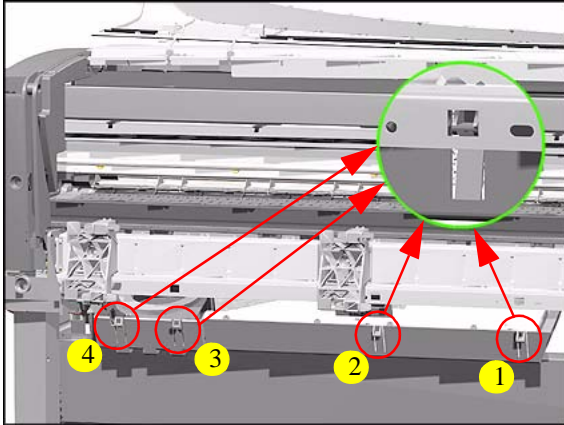

5. Unclip the Vacuum Fan Assembly from underneath the Printer.

NOTE Push in the clips of the Vacuum Fan starting from the right-hand side.

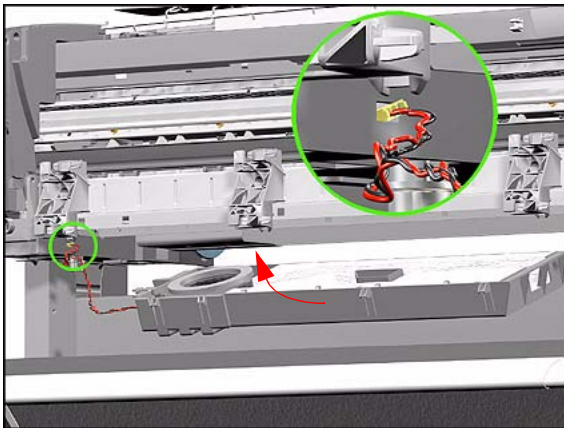

6. Remove the Vacuum Fan Assembly from the Printer.

NOTE When removing the Vacuum Fan Assembly, make sure you pull the Vacuum Fan cable through the hole in the Chassis.

Pinch-Arm

Removal

WARNING Switch off the printer and remove the power cord.

NOTE Refer to the table on Page 8-4 for information on screw types.

1. Remove the Spindle.
2. Remove the Back Platen (make sure the Pinch-Arm Lever is in the UP Position) - Refer to Page 8-17.
3. Remove 2 T-20 screws (**Type H**) from each Pinch-Arm.

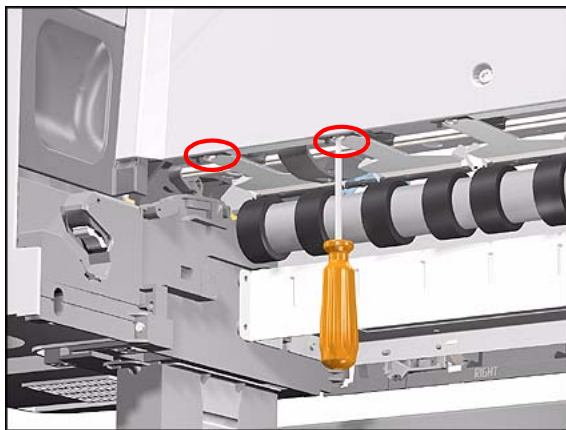

NOTE There 5 Pinch-Arms in the 42" Model and 3 in the 24" Model.

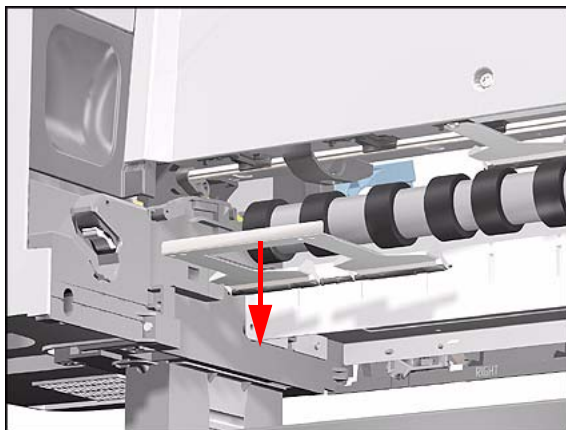

4. Remove the Pinch-Arm(s).

Pinch-Arm Mechanism

Removal

WARNING

Switch off the printer and remove the power cord.

NOTE

Refer to the table on Page 8-4 for information on screw types.

1. Remove the Back Platen (make sure the Pinch-Arm Lever is in the UP Position) - Refer to Page 8-17.
2. Remove ALL the Pinch-Arms - Refer to Page 8-66.
3. Remove 1 T-15 screw (**Type E**) that attaches the Cam to the Lever.

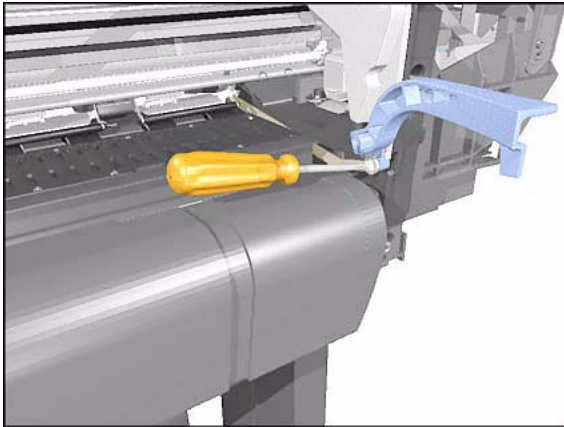

4. Remove 1 T-15 screw from the left hand side of the Cam.

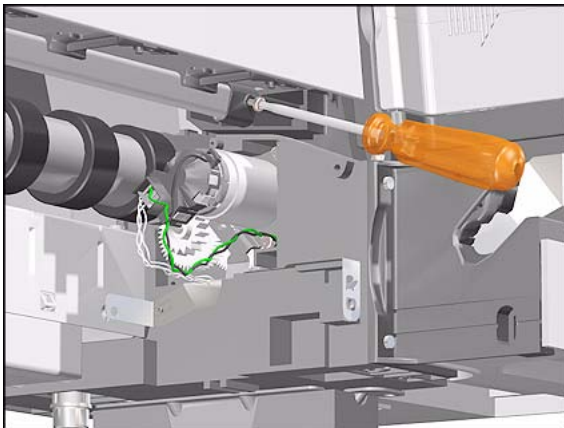

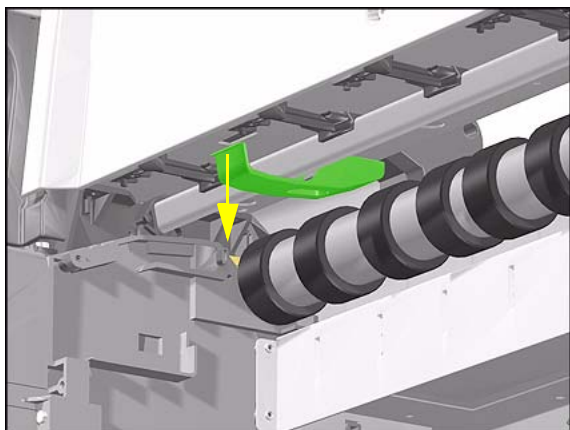

5. Open the Media Guide by unclipping it.

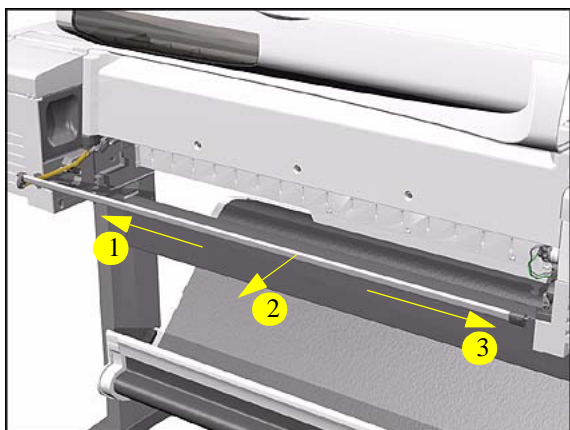

6. While pulling the Media Clip down, move the complete assembly to the left, towards you and then to the right and remove completely.

Pinch-Arm Lever

Removal

WARNING

Switch off the printer and remove the power cord.

NOTE

Refer to the table on Page 8-4 for information on screw types.

1. Remove the Right Hand Cover - Refer to Page 8-7.
2. Make sure the Pinch-Arm Lever is in the UP Position.

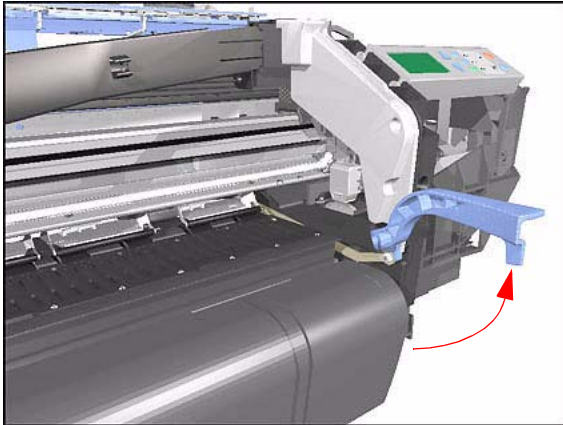

3. Remove 1 T-15 screw (**Type I**) and washer that secures the Lever to the chassis.

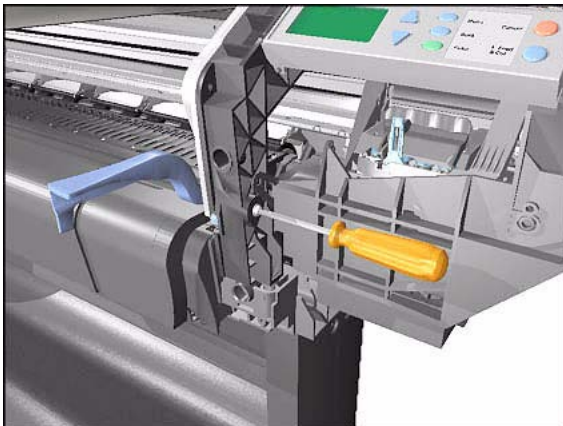

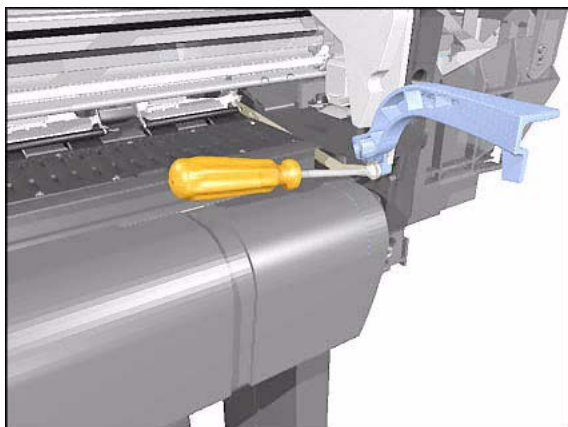

4. Remove 1 T-15 screw (**Type E**) that secures the Lever to the Cam.

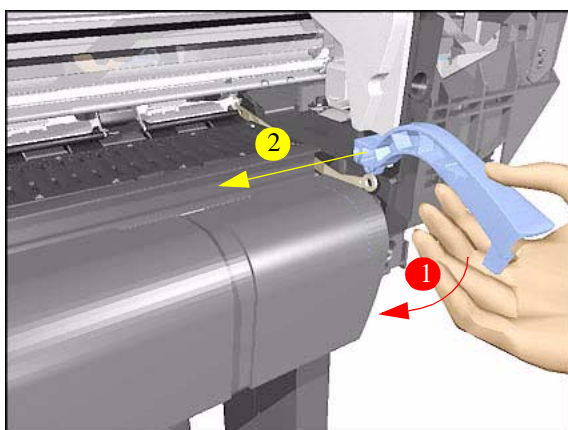

5. Lower the Pinch-Arm Lever and remove from the Printer (including the lever bushing).

Pinch-Arm Sensor

Removal

WARNING Switch off the printer and remove the power cord.

NOTE Refer to the table on Page 8-4 for information on screw types.

1. Remove the Right Hand Cover - Refer to Page 8-7.

2. Raise the Media Lever.

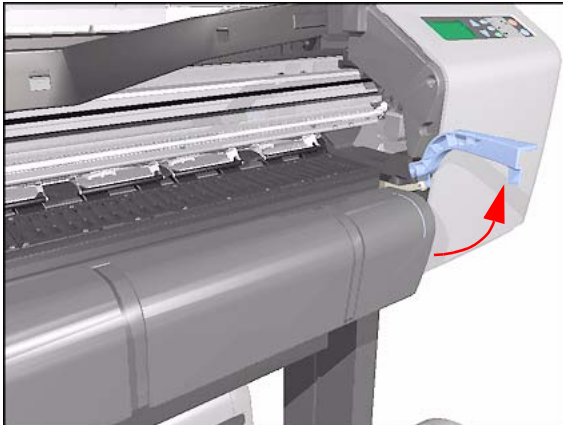

3. Lift tab up and slide Right Deflector to the **left** and lift up.

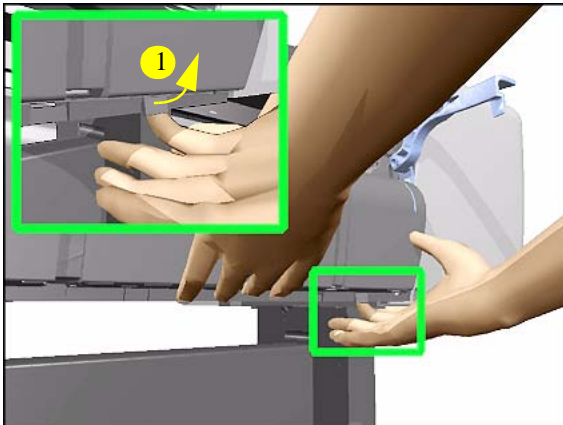

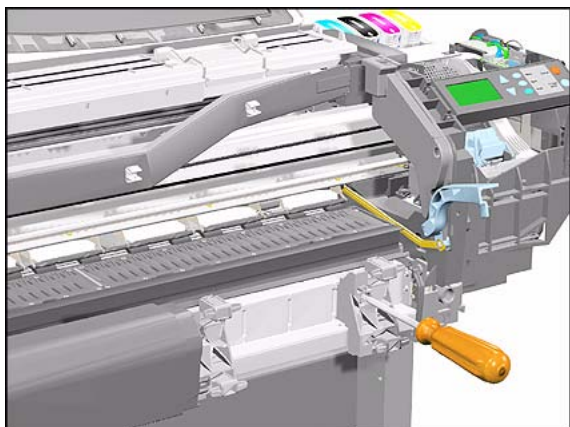

4. Remove 1 T-20 screw (**Type C**) from the Right Deflector Bracket.

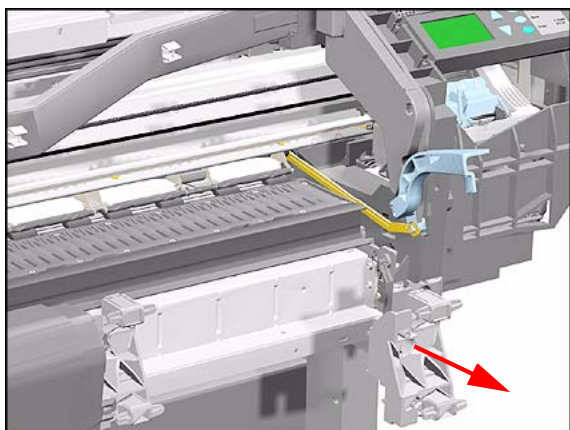

5. Remove the Right Deflector Bracket.

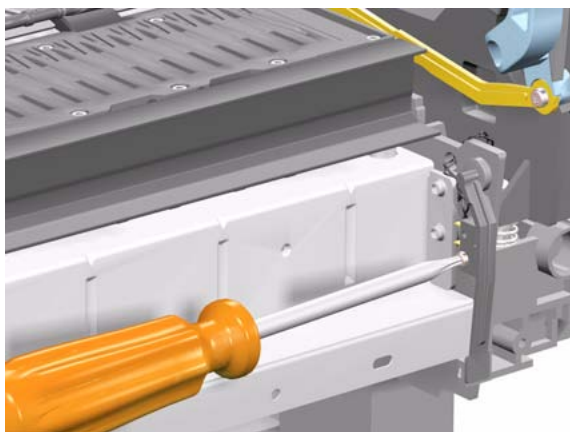

6. Remove 1 T-8 screw (**Type G**) from the Pinch-Arm Sensor.

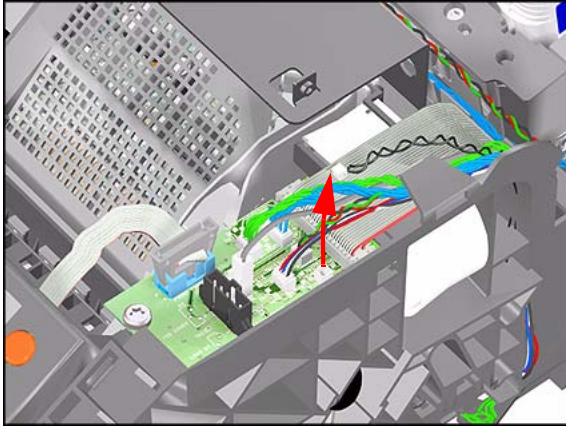

7. Disconnect the Pinch-Arm Sensor Cable from the Interconnect PCA.

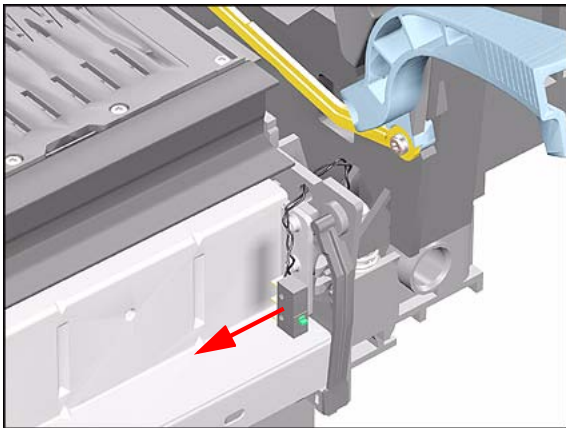

8. Remove the Pinch-Arm Sensor (including the cable).

Fork Idler, Tensioner and Idler Pulley

Removal

WARNING Switch off the printer and remove the power cord.

1. Remove the Left Hand Cover - Refer to Page 8-5.
2. Remove the Right Hand Cover - Refer to Page 8-7.
3. Release the tension from the right hand side of the Belt by pulling the Tensioner down and pushing it towards you to lock it into position.
4. Release the Belt from the Scan-Axis Motor on the left hand side.

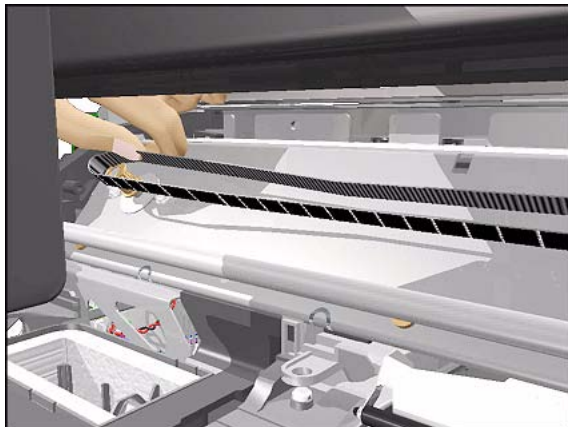
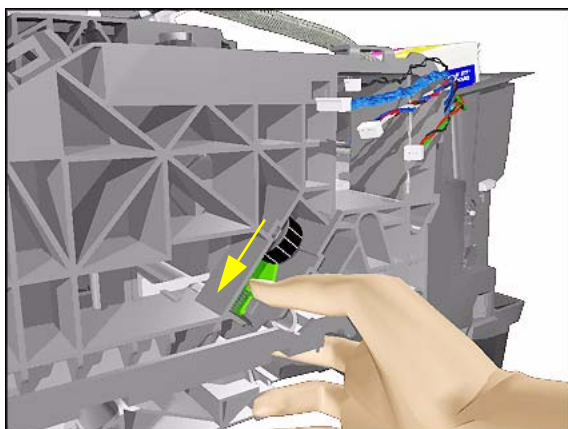

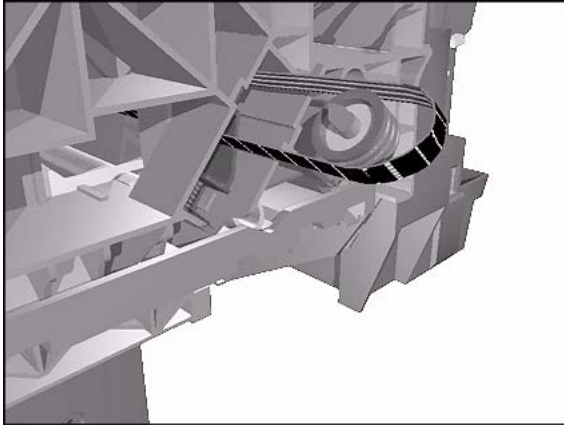

5. Pull out the Belt from the right hand side of the Printer and remove the Idler Pulley.

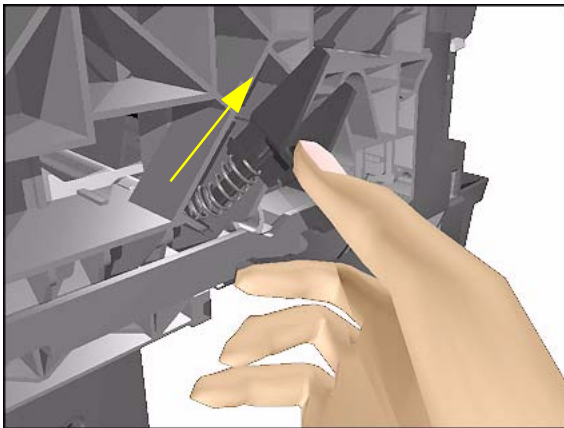

6. Unlock the Tensioner and remove from the Printer.

NOTE If it is too difficult to unlock the tensioner by hand, try using a Screwdriver (as a lever) instead.

Encoder Strip

Removal

WARNING Switch off the printer and remove the power cord.

NOTE Refer to the table on Page 8-4 for information on screw types.

1. Remove the Left Hand Cover - Refer to Page 8-5.
2. Remove the Right Hand Cover - Refer to Page 8-7.
3. Remove 1 T-15 screw (**Type E**) that secures the Encoder Strip to the Left Encoder Holder.

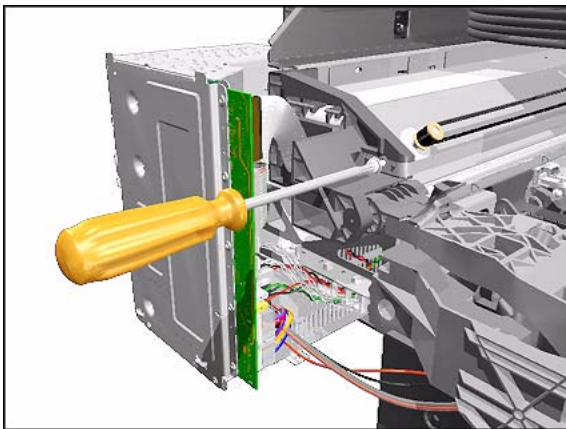

4. Release the Encoder Strip from the left hand side.

NOTE The Encoder Strip is sharp so be careful when touching it.

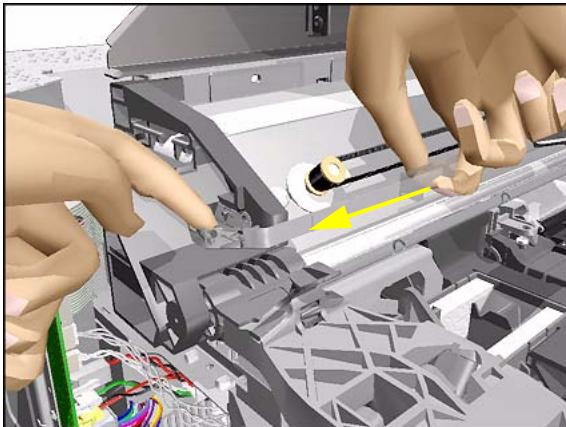

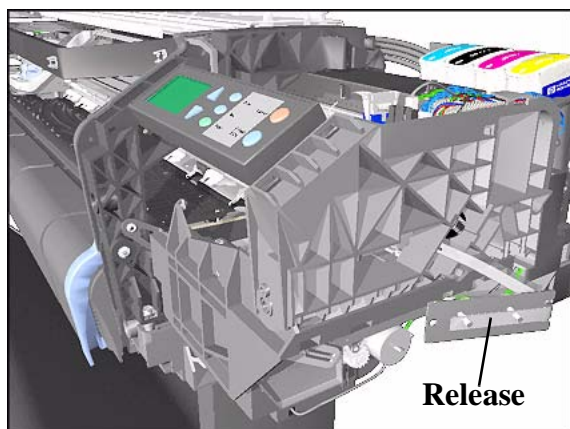

5. Release the Encoder Strip from the Service Station Holder.

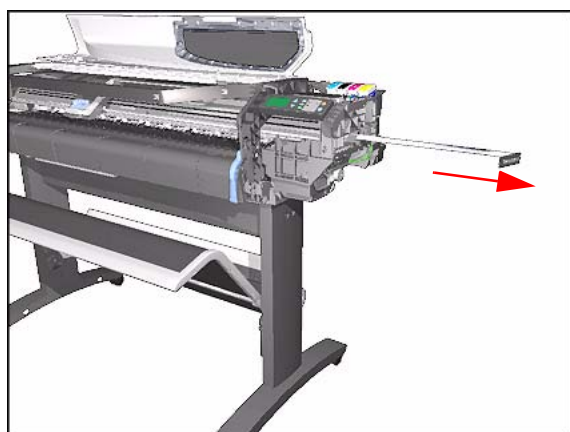

6. Remove the Encoder Strip from the Printer.

Carriage Assembly (Including Belt)

Removal

1. Perform the Service Utility "Unlock Carriage" - Refer to Page 4-22.

NOTE Switch off the Printer after performing this Utility.

2. Remove the Left Hand Cover - Refer to Page 8-5.
3. Remove the Right Hand Cover - Refer to Page 8-7.
4. Remove the Top Cover and Window - Refer to Page 8-10.
5. Remove the Front Panel Assembly - Refer to Page 8-9.
6. Remove the Service Station - Refer to Page 8-52.
7. Remove the Fork Idler, Tensioner and Idler Pulley - Refer to Page 8-74.
8. Remove the Encoder Strip - Refer to Page 8-76.
9. Remove the Service Station Holder - Refer to Page 8-57.
10. Manually move the carriage to the correct position to remove the Tubes Assembly from the Carriage.

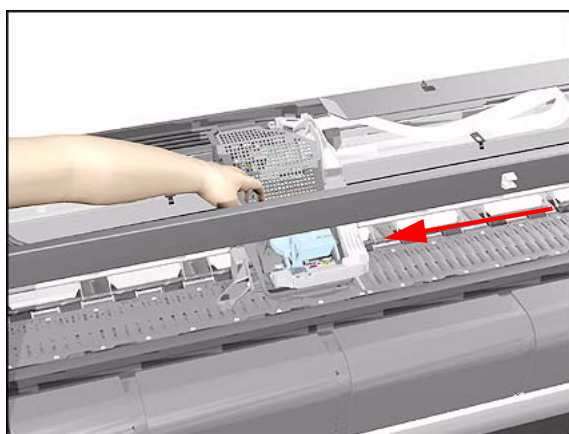

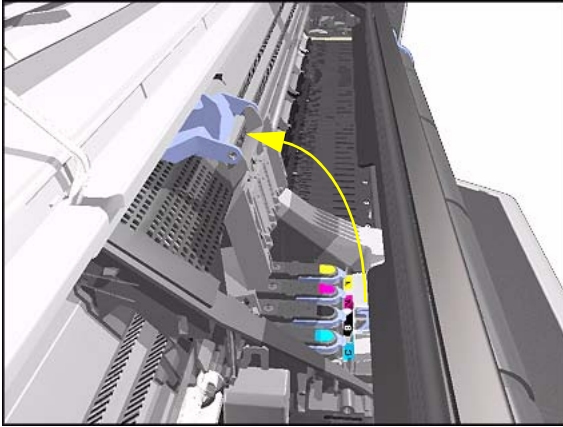

11. Release the latch and lift up the Carriage cover.

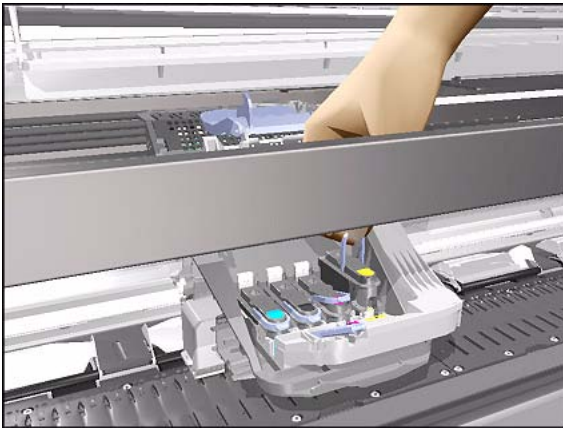

12. Remove all the Printheads.

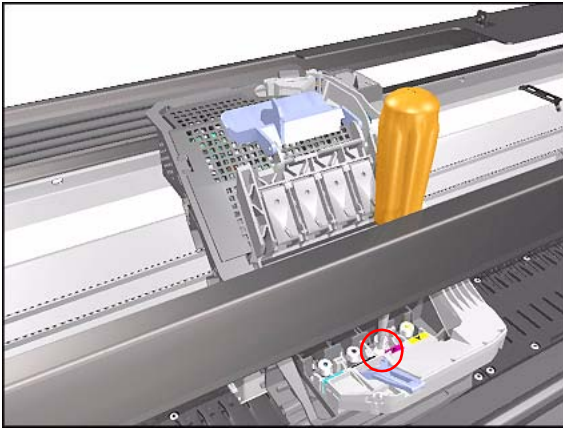

13. Loosen 1 T-8 screw that secures the Tubes to the Carriage.

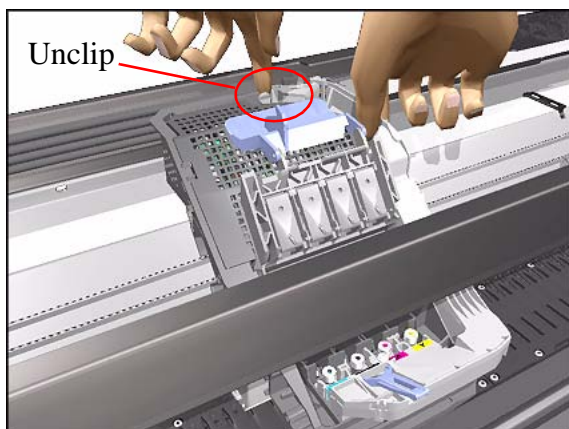

14. Unclip the Tubes from the Carriage and lift up.

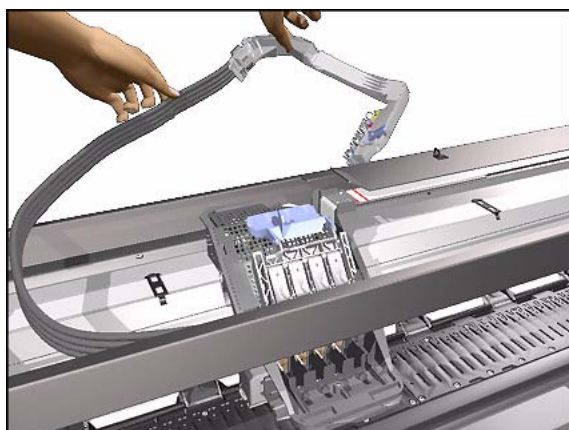

15. Move the Tubes Assembly clear from the Carriage Assembly.

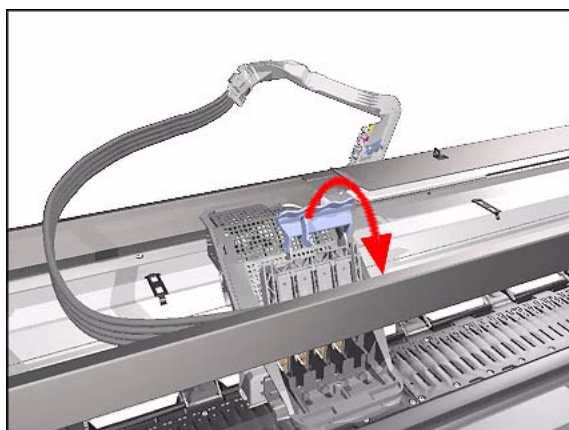

16. Close the Carriage Cover.

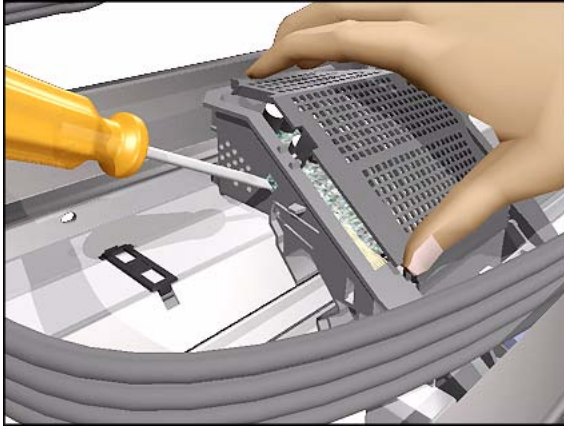

17. Unclip the Carriage Cover (clip located on the left hand side of the Carriage - use a screwdriver if necessary).

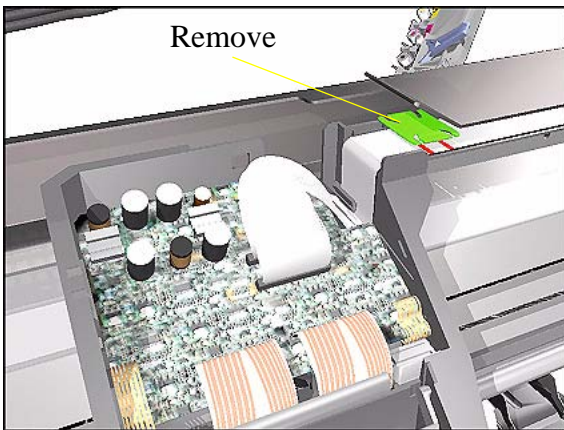

18. Remove the clip securing the Trailing Cable.

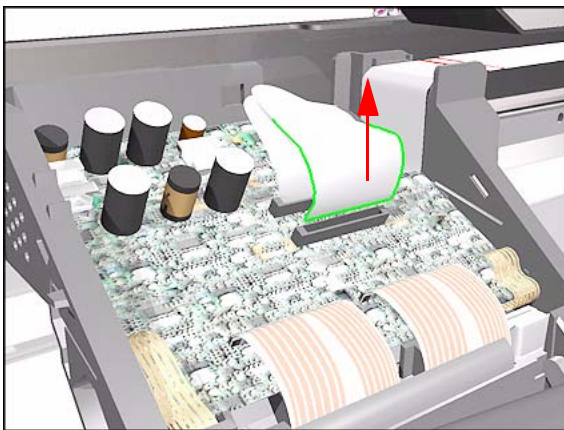

19. Disconnect the Trailing Cable from the Carriage Assembly.

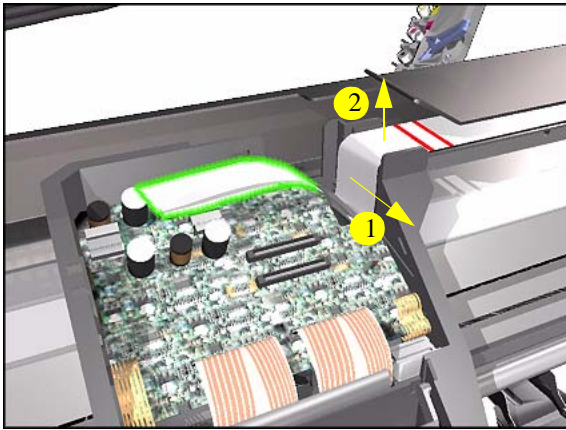

20. Slide the Trailing Cable out of the clip inside the Carriage Assembly and then lift up to free it from the Carriage.

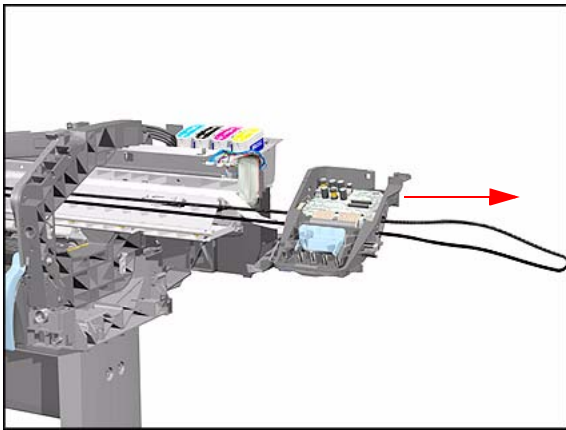

21. Slide the carriage (including the Belt) to the right and out of the Printer.

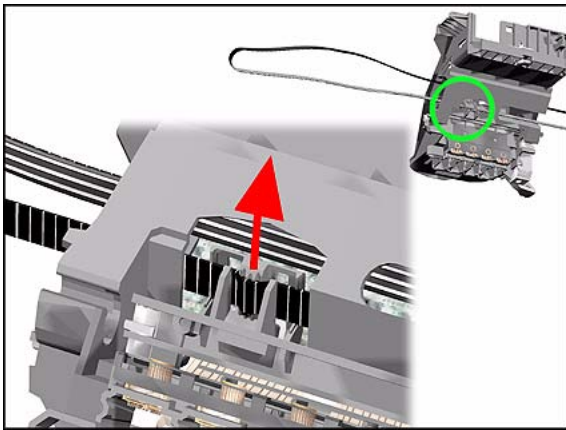

22. The Belt can then be slipped off the Carriage Clips.

Installing the Carriage Assembly

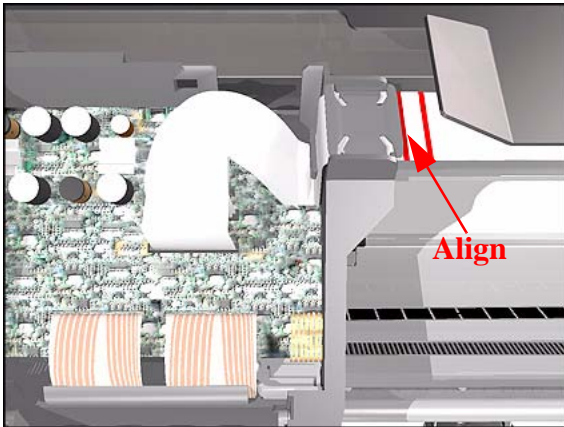

NOTE When connecting the Trailing Cable to the Carriage, make sure that you align the red lines on the Trailing Cable as shown in this drawing.

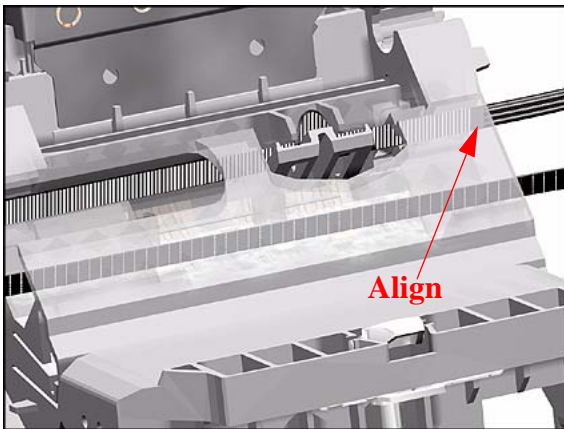

NOTE When installing the Belt, make sure that you insert it into the Carriage as shown in this drawing.

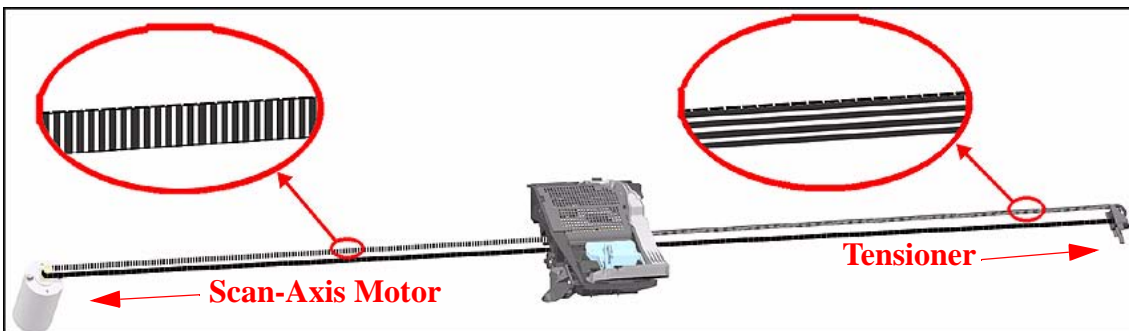

Paper-Axis Motor

Removal

WARNING Switch off the printer and remove the power cord.

1. Remove the Spindle.
2. Remove the Left Hand Cover - Refer to Page 8-5.
3. Remove the Back Platen (make sure the Lever is in the UP position) - Refer to Page 8-17.
4. Disconnect the Paper-Axis Motor Cables from the Electronics Module.

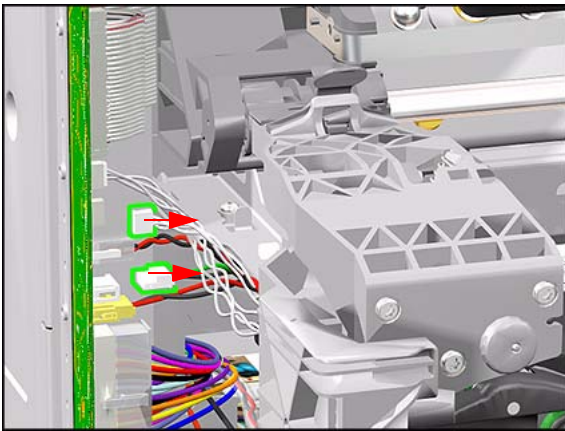

5. Remove 2 T-15 screws (Type J) from the Paper-Axis Motor.

NOTE Make sure that you keep hold of the Paper-Axis Motor when removing the screws, otherwise the Motor could fall and be damaged.

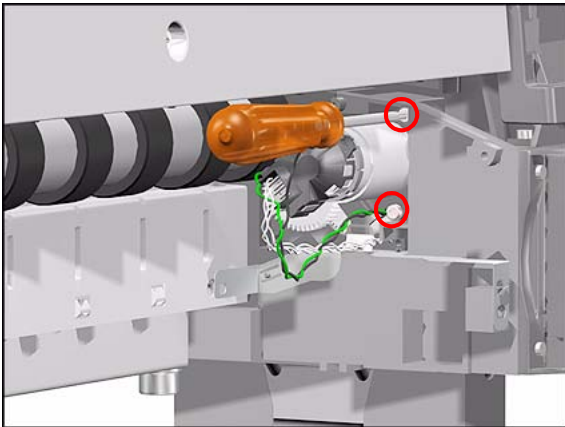

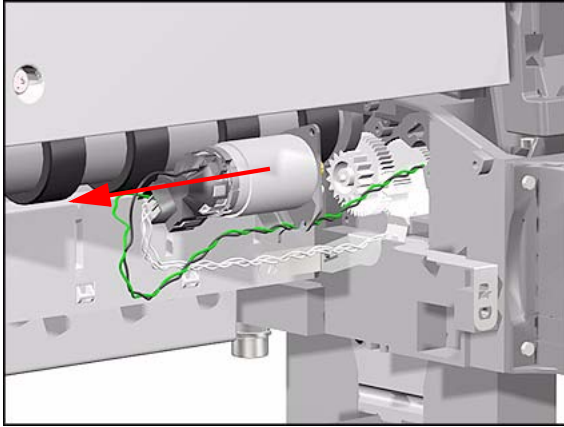

6. Remove the Paper-Axis Motor (including the cables).

Drive Roller

Removal

WARNING

Switch off the printer and remove the power cord.

1. Remove the Spindle.
2. Remove the Left Hand Cover - Refer to Page 8-5.
3. Remove the Right Hand Cover - Refer to Page 8-7.
4. Remove the Left and Right Trims.
5. Remove the Front Panel - Refer to Page 8-9.
6. Remove the Top Cover and Window - Refer to Page 8-10.
7. Remove all the Media Deflectors - Refer to Page 8-11.
8. Remove the Back Platen (make sure the Lever is in the UP position) - Refer to Page 8-17.
9. Remove the Media Sensor - Refer to Page 8-19.
10. Remove the Spittoon - Refer to Page 8-23.
11. Remove the Cutter Assembly - Refer to Page 8-32.
12. Remove the Cutter Guide Bracket - Refer to Page 8-36.
13. Remove the Drive Roller Encoder Sensor - Refer to Page 8-38.
14. Remove the Ink Supply Station - Refer to Page 8-48.
15. Remove the Cutter Guide - Refer to Page 8-55.

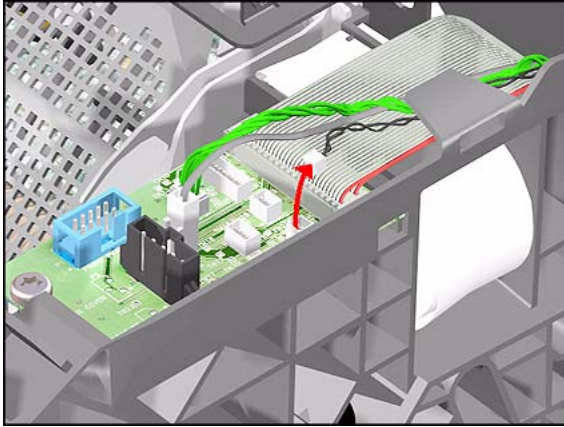

16. Disconnect the Pinch-Arm Sensor Cable from the Interconnect PCA.

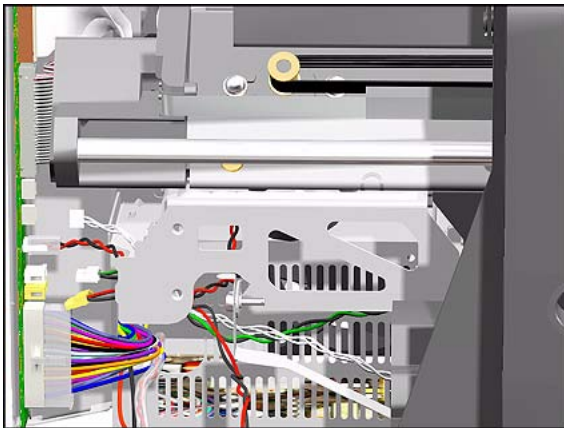

17. Disconnect the Paper-Axis Motor Cables and the Vacuum Fan Cable from the Electronics Module.

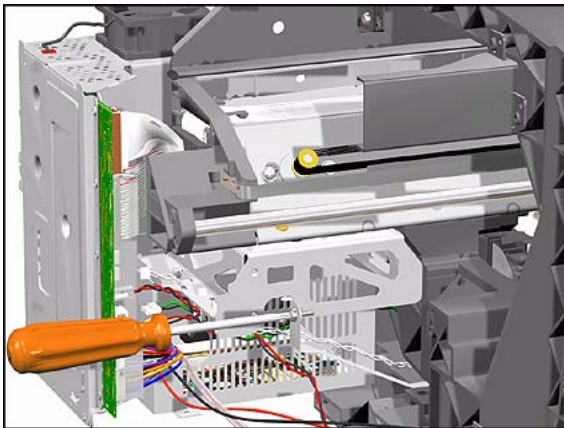

18. Remove 1 screw (T-10) from the Grounding Strip.

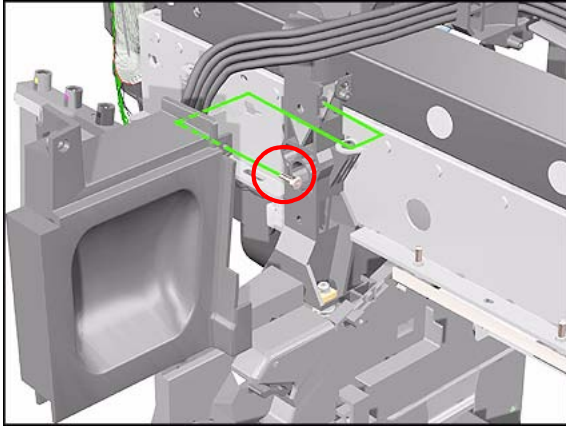

19. Remove 1 screw (T-15) from the Right Back Trim and remove trim.

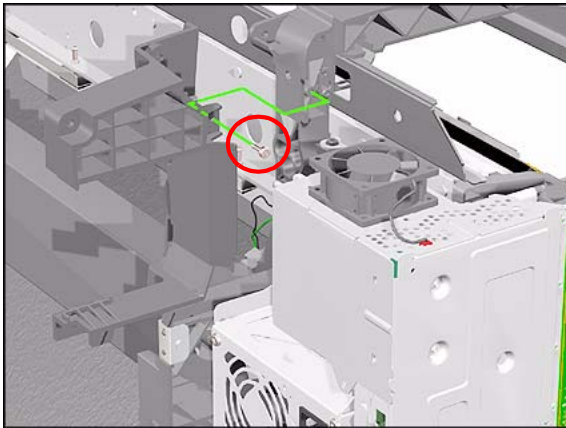

20. Remove 1 screw (T-15) from the Left Back Trim and remove trim.

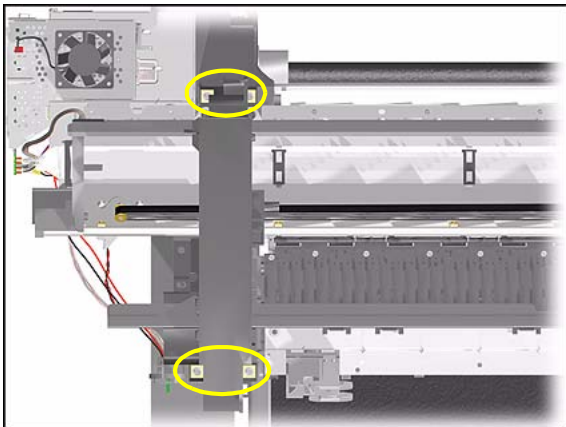

21. Remove 4 screws (T-25) that secure the Top Part of the Printer to the Bottom Part from the Left Hand Side.

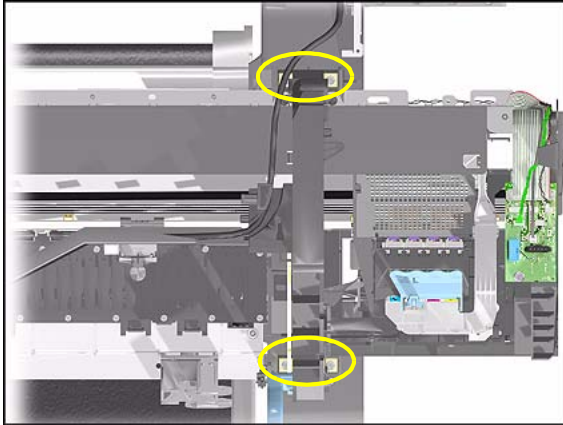

22. Remove 4 screws (T-25) that secure the Top Part of the Printer to the Bottom Part from the right hand side.

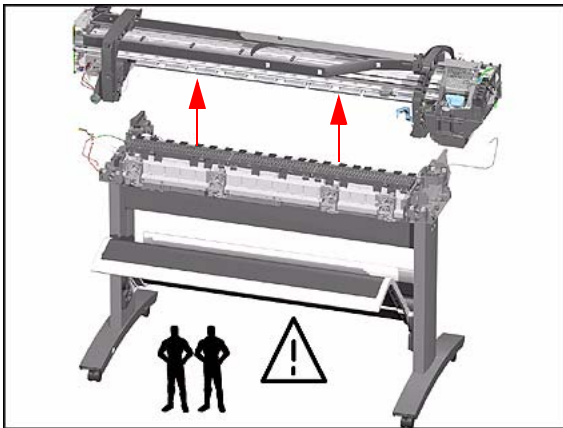

23. Make sure the Media Lever is in the UP Position and lift the complete Top Part of the Printer away from the Bottom Part.

NOTE The Top Part of the Printer is very heavy so 2 people should perform this step.

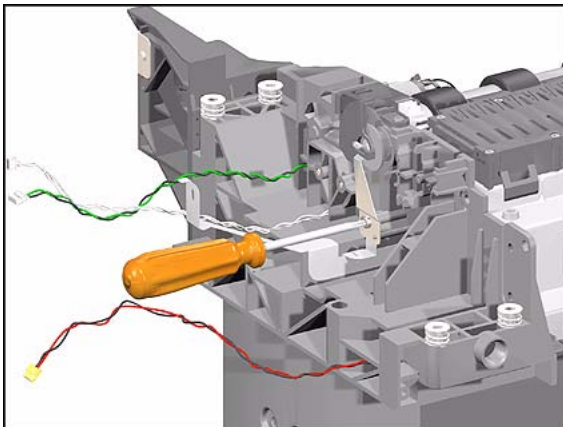

24. Remove 1 screw (T-15) from the Axle Spring.

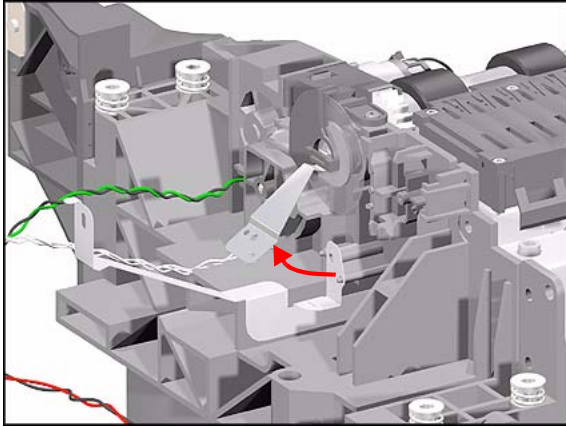

25. Remove the Axle Spring.

NOTE Be very careful when removing the Axle Spring because you could damage the Encoder Disc.

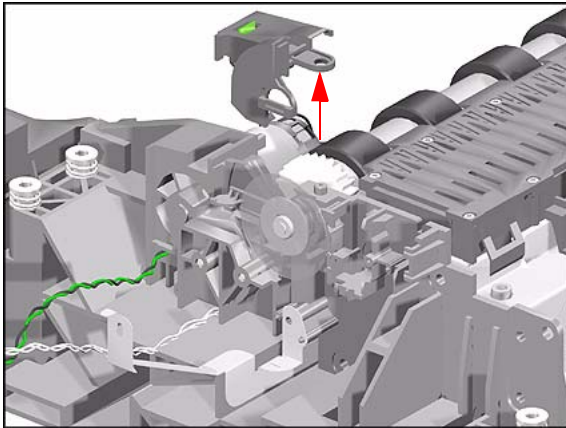

26. Remove the Encoder Disc Cover.

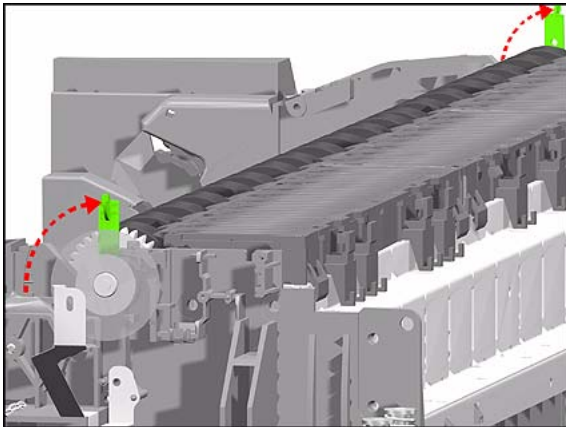

27. Release the levers on both ends of the Drive Roller.

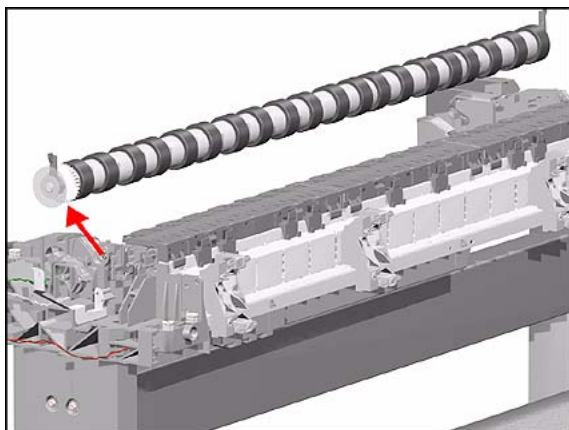

28. Lift Drive Roller out of the Printer.

NOTE Make sure you take care when lifting the Drive Roller because the Encoder Disc could get damaged.

Gear Assemblies

Removal

WARNING Switch off the printer and remove the power cord.

1. Remove the Spindle.
2. Remove the Left Hand Cover - Refer to Page 8-5.
3. Remove the Right Hand Cover - Refer to Page 8-7.
4. Remove the Left and Right Trims.
5. Remove the Front Panel - Refer to Page 8-9.
6. Remove the Top Cover and Window - Refer to Page 8-10.
7. Remove all the Media Deflectors - Refer to Page 8-11.
8. Remove the Back Platen (make sure the Lever is in the UP position) - Refer to Page 8-17.
9. Remove the Media Sensor - Refer to Page 8-19.
10. Remove the Spittoon - Refer to Page 8-23.
11. Remove the Cutter Assembly - Refer to Page 8-32.
12. Remove the Cutter Guide Bracket - Refer to Page 8-36.
13. Remove the Drive Roller Encoder Sensor - Refer to Page 8-38.
14. Remove the Ink Supply Station - Refer to Page 8-48.
15. Remove the Cutter Guide - Refer to Page 8-55.
16. Remove the Paper-Axis Motor - Refer to Page 8-84.

17. Remove the Drive Roller - Refer to Page 8-86.

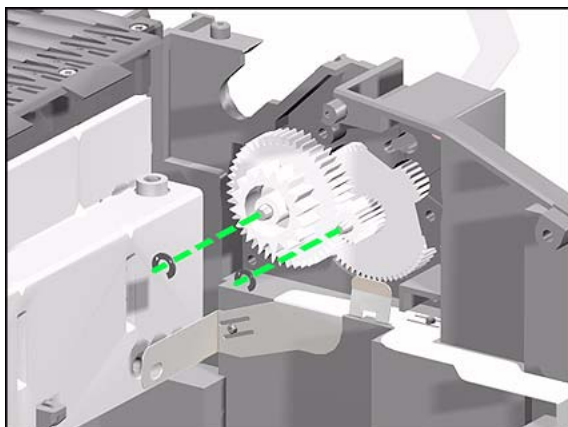

18. Remove the 2 locking pins from the Gears.

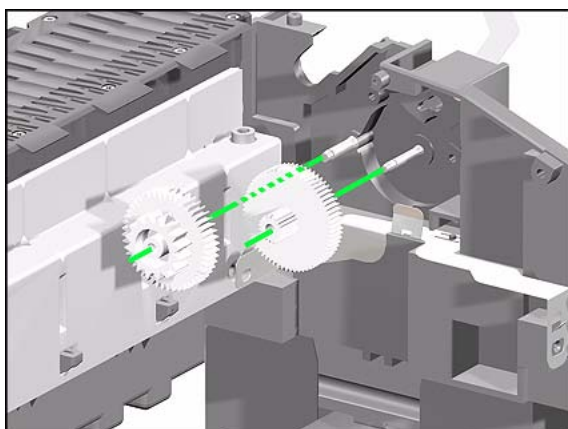

19. Remove the Gears.

Preventive Maintenance

9

Moisture on the Printer 9-2
Noisy Carriage Bushing 9-2
Belt Swelling 9-2
Cleaning the Printer 9-2
General Cleaning 9-2
Cleaning the Drive Roller/Print Platen 9-3
Scheduled Maintenance 9-3
Level of Printer Usage 9-3
Scan-Axis Maintenance 9-4

Preventive Maintenance

Moisture on the Printer

Users should use the Printer in an environment between 20% and 80% relative humidity. To recover from moisture condensation, turn the Printer Off, and, using the main roller as a reference, wait until the Printer is completely dry before using it again.

Noisy Carriage Bushing

To prevent noisy movement of the carriage, remove aluminum or dust particles from the bushing at the back of the carriage, and from the slider path along which the bushing moves.

Belt Swelling

To prevent new belts from swelling incorrectly, keep them in their bags with desiccant until you need to install them.

Cleaning the Printer

To maintain the Printer in good operating condition, keep it free of dust accumulation, ink, and other contamination. Cleaning intervals are determined by the Printer environment and by the types of Printer supplies used.

General Cleaning

Proper general cleaning should include the following:

- 1 Blow away dust accumulation with compressed air if available.
- 2 Clean the outer surface of the Printer with a damp sponge or cloth. Use a mild soap and water solution if necessary. Do not use abrasive cleaners.
- 3 Wipe the Printer dry with a soft lint-free cloth.

Cleaning the Drive Roller/Print Platen

NOTE

If ink is spilled on the Drive Roller or the Print Platen, remove the ink. Due to the ink's reflectance, ink on the Drive Roller or the Print Platen can disrupt the Printer's edge-sensing function. To remove any ink from the Drive Roller, perform the following procedure:

WARNING

Prevent water or other liquids from running onto electrical components or circuits, or through openings in the module.

- 1 Perform the Turn Drive Roller Utility ⇒ Page 4-21.
- 2 Open the Top Cover and apply any common household cleaning solution (water based only) to a soft, lint-free rag and apply it to the Drive Roller surface while it is rotating. Thoroughly clean the Drive Roller surface.
- 3 Press **Enter** when you have completed the cleaning procedure.
- 4 Allow the Drive Roller to dry before loading media in the Printer.

Scheduled Maintenance

In some segments of the printer market, the customer tends to print more than the maximum number of prints that the throughput allows, exceeding by far the limit of the design. When this happens the customer runs into print quality problems and continuous Printer failures.

The purpose of scheduled preventive maintenance is to avoid these failures - ensuring a good performance during all the product life.

Level of Printer Usage

Normal printer use means 6,000,000 printing carriage cycles. Under normal usage conditions, it will be approximately 5 years before the printer needs maintenance. If the printer is used more than the normal usage conditions, then it will need maintenance service much more frequently.

One of the EEROM counters is assigned to counting the number of carriage cycles as well as the usage cycles of other major components. When the printer exceeds this amount, the front panel

displays the following message:

"Maintenance Advised"

NOTE

The Maintenance Advised message could also appear when the Spittoon in the Service Station is full.

The Printer Information utility also conveys the usage information, and it is accessible by the user.

Once the maintenance advised message is displayed, the preventive maintenance kit must be used to replace the most worn parts of the printer. Use the Removal and Installation Chapter of this Service Manual as a guide to replace the necessary parts.

Scan-Axis Maintenance

In addition to the wearing of the Scan-Axis Motor and the Ink Tubes System, the friction in this area can increase due to the accumulation of ink particles and dust from the media or the atmosphere in the vicinity of the slider rods.

Scan-Axis maintenance requires the cleaning of the slider rods properly, and a lubricant to apply onto the rods. It also requires the replacement of the Ink Tubes System.

NOTE

The most important parts to keep clean are the upper and internal sides of the rods.

Functional Overview

10

Introduction	10-2
SKU Overview	10-2
Electrical System	10-3
Power Supply Unit (PSU)	10-5
Front Panel	10-6
Ink Delivery System (IDS)	10-7
Ink Supply Station (ISS)	10-7
Tubes Assembly	10-9
Service Station	10-10

Introduction

This Chapter contains a simplified description of the HP DesignJet 500/800 Printer circuits and mechanical functions. Mechanical and Printed Circuit Assembly (PCA) overviews present a functional description of how the Printer operates.

SKU Overview

In total there are 8 SKU's which are detailed as follows:

	Windows HP DesignJet 500	Windows HP DesignJet 500PS
Part Number	24" Model - C7769B 42" Model - C7770B	24" Model - C7769C 42" Model - C7770C
Resolution	1200 x 600 dpi	1200 x 600 dpi
Languages	<ul style="list-style-type: none"> ■ Raster Data Only ■ HPGL/2 Upgrade (still 600 dpi) 	<ul style="list-style-type: none"> ■ MAC/WIN PostScript RIP
Memory	16 MB (no expansion needed)	16 MB (no expansion needed)
Hard Disk	Not available	Not available
Network Card	Option	Option
Formatter	Option	Option

	Power CAD HP DesignJet 800	GA HP DesignJet 800PS
Part Number	24" Model - C7779B 42" Model - C7780B	24" Model - C7779C 42" Model - C7780C
Resolution	2400 x 1200 dpi (Super Best)	2400 dpi (Super best)
Languages	<ul style="list-style-type: none"> ■ HPGL/2 	<ul style="list-style-type: none"> ■ PostScript Level 3 ■ HPGL/2
Memory	96 MB (expandable to 160 MB)	160 MB
Hard Disk	6 GBytes (Queuing)	6 Gbytes (Asian Fonts included)
Network Card	Standard	Standard
Formatter	Standard	Standard

Electrical System

Introduction

The Printer's engine electronics (Main PCA) is controlled by a Kayak ASIC. Kayak is the application-specific integrated circuit (ASIC), designed in Hewlett-Packard's Vancouver Printer Division, forming the heart of the thermal-inkjet large format printer digital electronics.

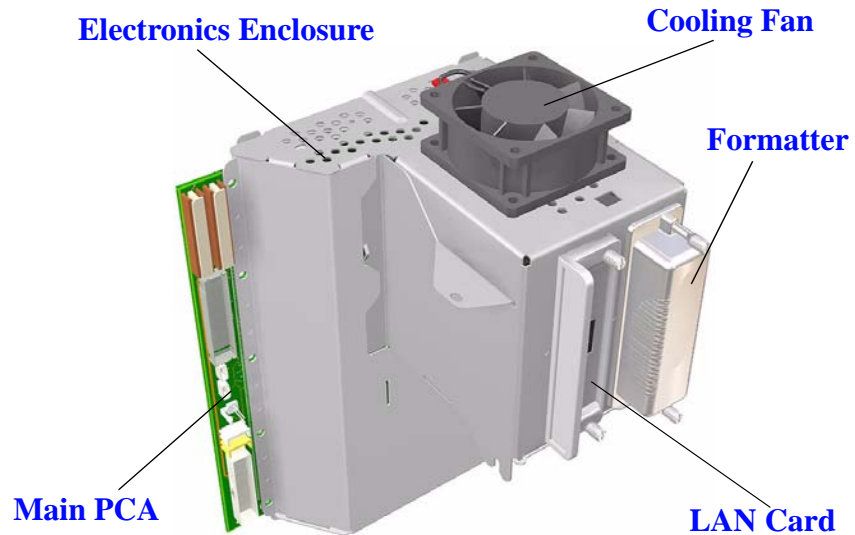

Hardware Description

- The Kayak ASIC is fed with a 15.975MHz crystal-quartz which through a phase lock loop (PLL) is raised to 192MHz and after that divided to the ColdFire frequency of 96MHz and further divided to the external memory bus of 48MHz.
- The Kayak ASIC incorporates the CF3_g Motorola CF3MRSX processor mega cell. As implemented in Kayak, the processor, with 8KB of unified cache, has a maximum operating frequency of 98MHz and at this frequency it is capable of approx. 70 MIPS.
- Two physical EIO slots are supported from which the optional formatters and EIO cards will be plugged. Three expansion options are currently supported.
- The Main PCA will come with an on-board 2MB(x16) flash memory that will allow both the end user and service engineers to upgrade with the latest firmware code available.
- A total of 16MB SDRAM (x32) or 32MB SDRAM (depending on the Printer Model) will be loaded in the engine PCA, not allowing further user self-memory upgrades.

- The memory bus is also used to control Navata gate array. Navata is a customized ASIC to control most of the Printer's sensors (ISS optical sensors, pinch wheels, digital encoder, etc.), Power Supply, Scan-Axis Motor driver, Vacuum Fan, Front Panel, Carriage, etc.
- A 16k serial EEPROM is used to store different line calibration parameters and the Printer's life history (number of plots, etc.). The ISS PCA also contains an EEROM that contains a backup of all critical parameters from the Main EEROM.
- The Main PCA has an analogue IC which controls two DC motors (IDS and paper) and one stepper motor (Service Station). This IC, as well as the IC in the Carriage PCA, is controlled through the VPR serial interface from the Kayak ASIC at a bus clock frequency of 1.6MHz.
- From the Main PCA the Interconnect Cable connects to the Interconnect PCA (located on the right hand side of the Printer) which then splits into different subsystems: Front Panel, IDS PCA, Aerosol Fan, Service Station and media loading sensors (pinch, media sensor and media button).
- Two discrete drivers are implemented for the Carriage Motor driver and the Vacuum Fan.
- The Main PCA comes with fully protected motor drivers for Carriage, Paper-Axis, Service Station and IDS motors. Any short-circuit will be detected and protected.
- Trailing Cables come with an interlock loop that will prevent from turning on voltages in the Carriage while the Trailing Cable is not properly connected. A similar approach of using an interlock pair is used in the Interconnect Cable to ensure it is properly connected.
- The EIO slots do not allow for hot insertions while the machine is powered. **That is why it is very important to always power-off the Printer before inserting the EIO Card or the Formatter or else the Main PCA could be burned.**
- Serial channel, to be used for line production and service purposes only, will be isolated from Kayak pins with a GPIO in the Navata ASIC.

Power Supply Unit (PSU)

The PSU is used to supply the power required by the printer in any condition and has the following features:

- 130W maximum continuous average power (171 W at peak) with power factor correction.
- 4 outputs with voltages of +5.0V, +3.3V, +12V and +32V.
- Operates with convection cooling when +32V output is at minimum load but the Power Supply is cooled by forced air provided by a fan in the Power Supply enclosure when the +32V output is loaded.
- The Power Supply is connected directly to the Power Switch and a green LED located at the front of the Printer on the bottom left hand side.

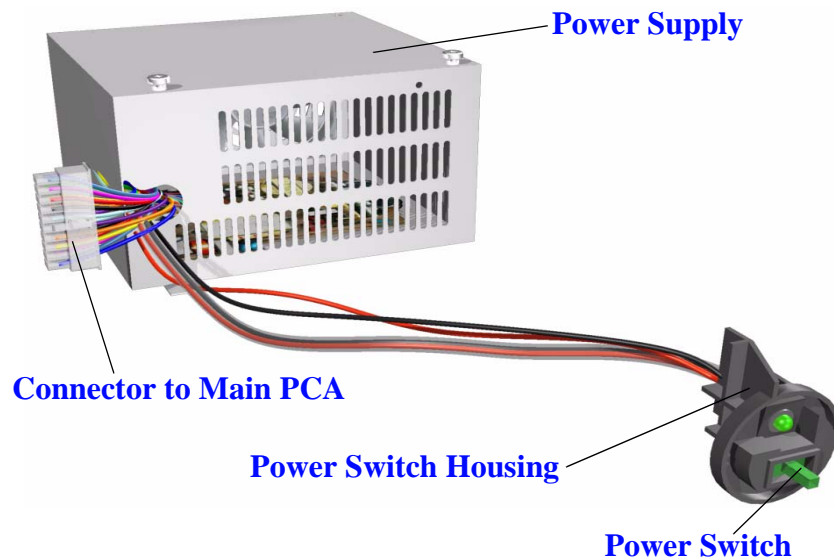

The Power Supply operates over a voltage range as described in the following table:

Rated Voltage	100-240 VAC
Normal Operating Range	88 - 264 VAC
Functional Operating Range	80 264 VAC
Rated Frequency	50/60 Hz
Frequency Test Limits	47 -63 Hz

As explained earlier, the Power Supply provides +5.0V, +3.3V, +12V and +32V to the Main PCA with the following maximum output currents:

Voltage	Maximum Output Current (A)	Systems
+3.3V	8.0	Digital Logic & EIO cards
+5.0V	1.7	Sensors, Front Panel, Bitronics and some analog logic in Main PCA
+12.0V	0.45	Aerosol & Cooling fans and to generate the 5.0V going to the carriage
+32.0V	3.7	Motors, Vacuum Fan and carriage

Front Panel

The user can interact with the printer in two ways: from the host via the I/O channels or directly via the front panel. The Front Panel is used to display messages (like the status of the machine or warnings), to configure the printer and to send commands to it (cancel the job or print a demo for example).

The Front Panel has an LCD display, 7 keys (no LEDs) and a buzzer (to provide audible feedback to the user).

The front panel display is a 128 x 64 pixel graphic LCD. Every pixel can be activated individually and the controller present on the Front Panel board allows it to display both text and graphics at the same time. The Front Panel has a positive reflective type display to improve its viewing characteristics and does NOT have an LED backlight.

The Front Panel is connected to the Interconnect PCA and NOT directly to the Main PCA.

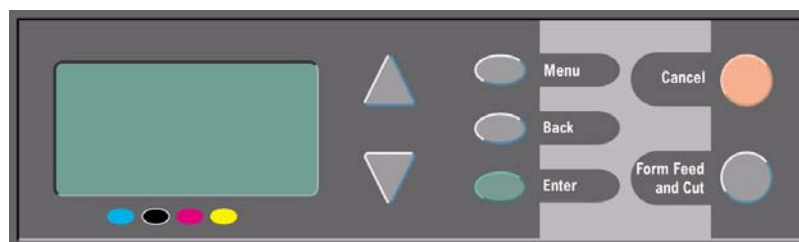

Ink Delivery System (IDS)

The Ink Delivery System (IDS) delivers ink from the off-axis Ink Cartridges via permanently connected tubes to the high throughput Printheads for the HP DesignJet 500/800 Series Printers

The IDS consists of two major subsystems:

- The Ink Supply Station (ISS).
- The Tubes Assembly.

Ink Supply Station (ISS)

In the Printer, the Ink Cartridges reside inside the Ink Supply Station (ISS). The ISS is situated on the right hand side of the Printer and will be able to handle 69cc capacity Ink Cartridges (for all colors). The ISS is the part of the Printer that provides the pressure to pump the ink from the Ink Cartridges to the Printheads. It has a mechanism for each one of the four Ink Cartridges. Each mechanism consists of a spring that pulls from a rocker that pushes the lifter that pressurizes the bongo. There is a camshaft, which is driven by an electric motor, that moves the four lifters down pressing on the rocker. The ISS also has sensors which can detect when the pump chamber is empty and needs to be refilled (by pushing down the lifters).

The following diagram explains the operation of the ISS:

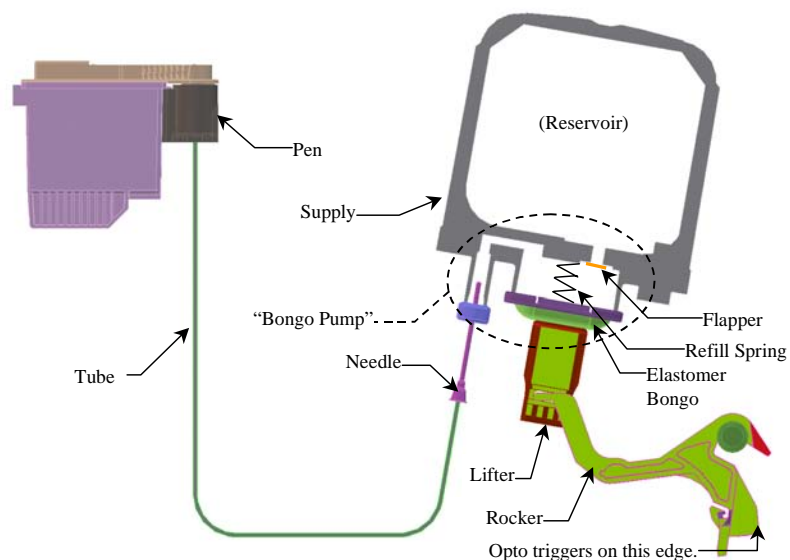

These are the key functions of the ISS:

- Ink Cartridges support and location.
- Prevents incorrect insertion of colors and inks.
- Provides electrical connection to the Ink Cartridges.
- Locates the supply end of the Tubes Assembly.
- Contains ink from leaks.
- Includes the ISS PCA which contains the backup EEROM.

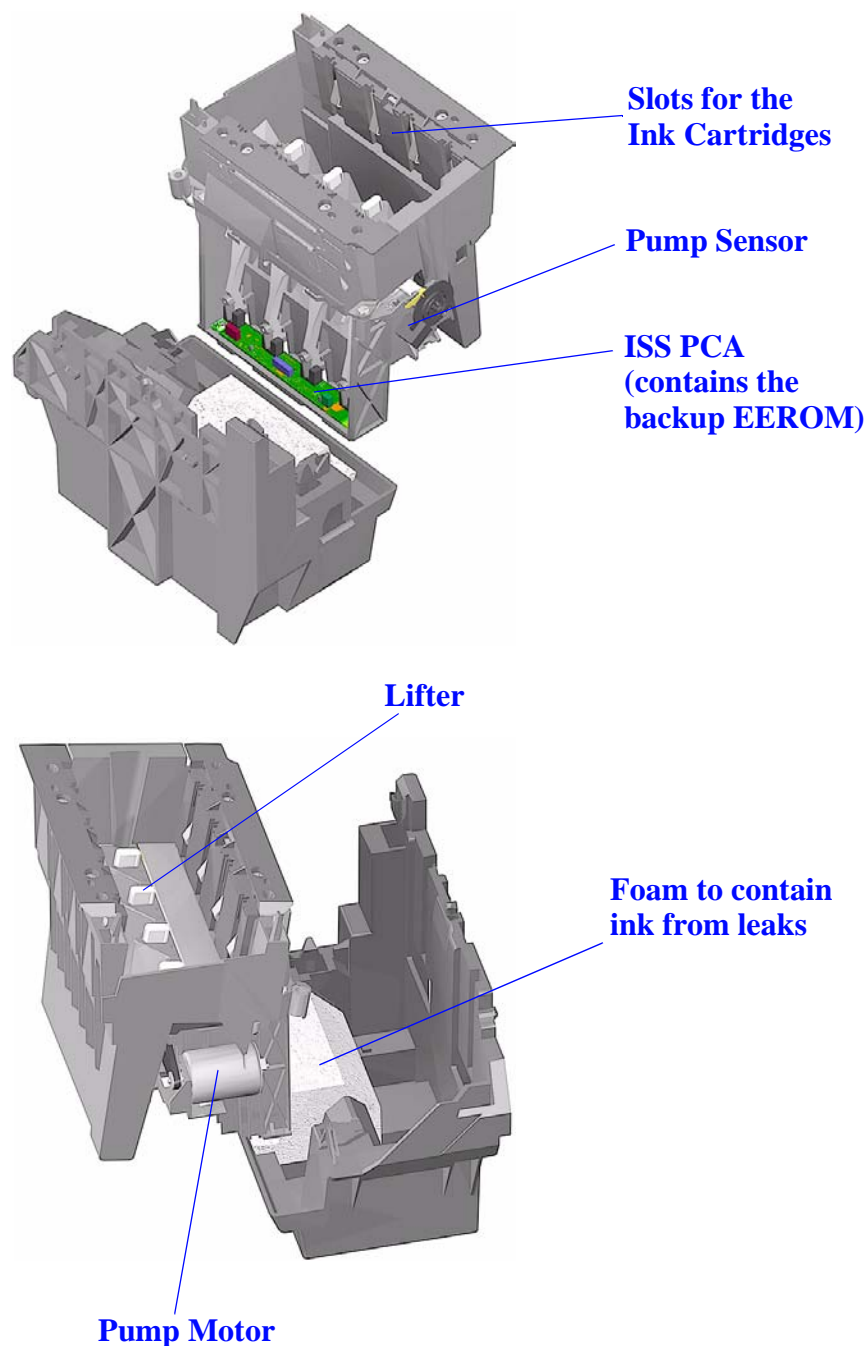

Tubes Assembly

The Tubes Assembly is the part of the Ink Delivery System which physically drives the ink from the Ink Cartridges in the ISS to the Printheads in the Carriage Assembly. The ink flows through a flexible tube from the ISS to the Carriage by means of the pressure applied by the pumping device in the ISS.

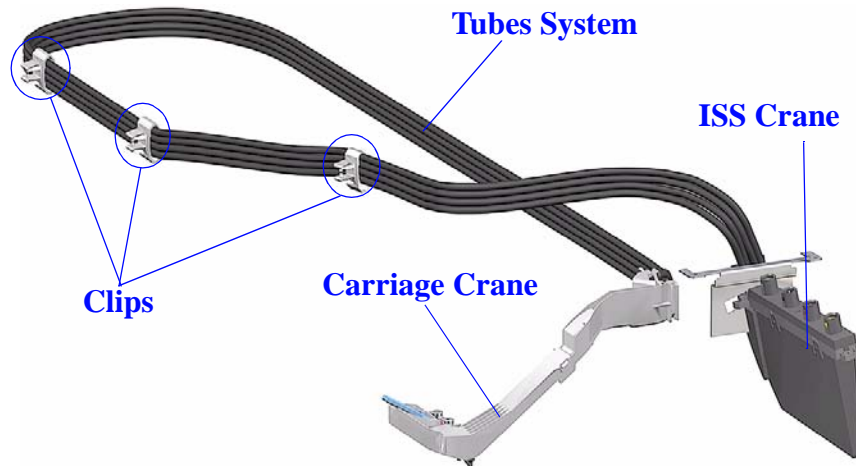

In both ends of the tubes there are fluidic interconnections which are designed to prevent any kind of ink leakage, and minimize the ink on customers as they interact with the system (i.e. when they must replace Ink Cartridges or Printheads).

While the Ink Cartridges remain static in the ISS, the Carriage goes back and forth along the scan-axis of the Printer. That is why the **tubes** have to be flexible in order to follow this movement.

Since the condition of the ink determines its performance on the printing media (and therefore the print quality output), the Tubes Assembly must guarantee the properties of the ink coming from the Ink Cartridges until it is delivered to the Printheads. This 'healthy' condition is defined by means of maximum water vapor losses and air ingestion that the ink can get along time.

Service Station

The purpose of the Service Station is to service the Printheads in order to guarantee their performance along their specified functional life in the following ways:

- Wiping of Printheads nozzle plate surface.
- Applying dissolvent on the Printheads nozzle plate surface.
- Capping the Printheads when they are not printing.

The Printhead also performs a spitting action in order to recover or refresh the nozzle performance, therefore the Service Station contains a Spittoon to retain the ink thus reducing the risk of ink leakage. A secondary Spittoon, which performs the same routine, is located on the left hand side of the Printer.

The function of wiping is to remove ink residue and external debris from the Printhead so that good drop ejection and nozzle performance is maintained throughout the life of the Printhead.

To help dissolve the ink spread on the nozzle plate and also to lubricate the wiper as it scrubs the nozzle plate, some dissolvent and lubricant (PolyEthileneGlycol 400) is applied to the Printheads nozzle plate (also by means of wiping).

Also, the Aerosol Fan is located at the bottom of the Service Station, so if the Aerosol Fan fails for any reason, the complete Assembly (Service Station and Aerosol Fan) needs to be replaced.

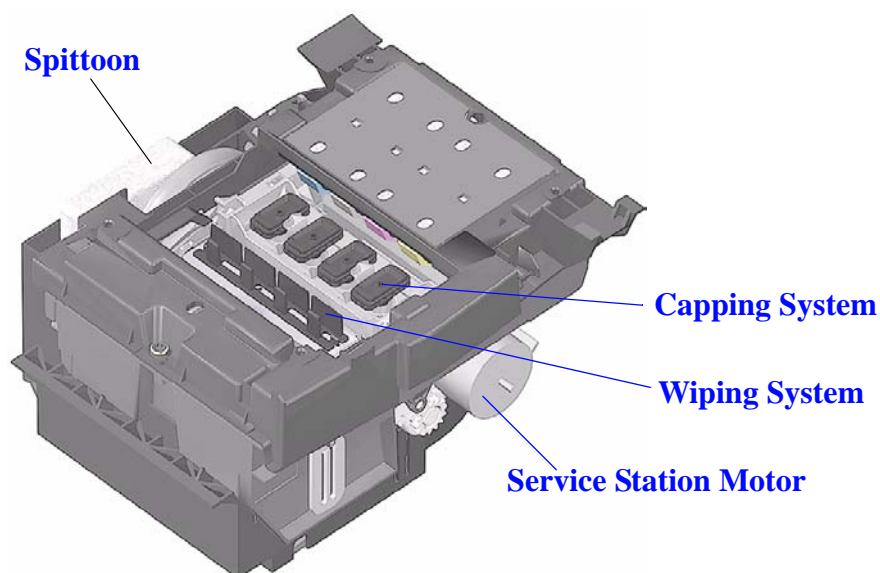

Glossary

ac

Alternating current.

ANSI size

An American standard media size; e.g. D, E

application

The software you use to create your drawings.

APS

Air Pressurization System

Centronics

A standard for the parallel interface between computer and device.

clipping

Losing part of a drawing at the edges.

CMYK

Cyan, magenta, yellow and black. The colors of the printer's four inks, and also a standard color model.

coated paper

Paper coated on one side for inkjet printing.

default

A value or condition that is assumed if no other value or condition is specified.

device

An external item connected to the computer: printer, plotter, tape drive, etc. Your HP DesignJet is a device.

dpi

Dots per inch, a measure of print resolution.

driver

The software that controls the communication between a computer and a device.

front panel

The control panel on the right of the printer.

front-panel menus

The structure of options in the front-panel display.

graphics language

A programming language telling a print device how to output graphic data.

grayscale

Shades of gray to represent colors.

high-gloss film

A glossy, opaque, polyester media type.

high-gloss photo

A glossy, opaque photographic paper.

HP-GL/2

One of Hewlett-Packard's standard graphics languages for plotters and printers. Produces vector data. Newer than HP-GL.

IDS

Ink Delivery System.

I/O Input/output

The transmission of data between a computer and a device.

inked area

The smallest rectangle that contains all the content of the drawing, while maintaining its relative dimensions.

ISO size

An international standard media size; e.g. A1, A2, etc.

ISS

Ink Supply Station

JIS size

A Japanese standard media size.

LAN

Local area network.

LDS

Leak Detect System

long-axis printing

Printing a page whose X-axis (the axis vertical to the printer as you look at it from the front) is longer than a standard page size.

margin

The space around the page added by the printer to separate one page from another and to avoid printing right to the edge of the media.

matte

Not glossy.

media

The material, usually paper, onto which the printer prints.

nesting

Placing two or more pages side-by-side on roll media to avoid waste.

palette

A set of logical pens defined by color and width.

Paper-axis

The vertical axis, as you look at the printer from the front.

PJL

Printer Job Language. A programming language that controls jobs going to a printer.

PML

Printer Management Language.

parallel interface

A type of interface between computer and device. Generally faster than a serial interface.

PANTONE

The PANTONE MATCHING SYSTEM® is an international standard for color communication in the graphics art industry.

pen

Even though the plotter has no physical pens, the lines it draws match the attributes of a pen.

platen

The exterior part of the printer on which the media rests before going into the media-entry slot.

printing area

Page size minus margins.

PostScript

A standard page-markup language, commonly used by graphics and desktop publishing software applications.

PSU

Power Supply Unit.

queueing

Placing each print received by the device into memory for processing with other prints.

raster

A method for defining an image, in terms of dots rather than lines. Raster data typically needs more memory than vector data.

RGB

Red, green and blue. A standard color model.

RIP

Raster Image Processor.

RTL (Raster Transfer Language)

One of Hewlett-Packard's standard graphics languages for plotters and printers. Produces raster data.

ROM DIMM

A physical module containing read-only data, that can be installed in the back of the printer to provide upgrades.

Scan-axis

The horizontal axis, as you look at the printer from the front.

semi-gloss photo

A semi glossy, opaque photographic paper.

spindle

The rod which holds the roll of media.

Index

A

Advance Calibration 5-9

B

Back Platen 8-17

Banding 1-6

Belt 8-78

Belt Swelling 9-2

Boot-Up Sequence 1-12

C

Carriage Assembly 8-78

Carriage Movement Test 4-8

Change Cutter 4-24

Change Ink Tubes 4-25

Cleaning

 Drive Roller 9-3

 General 9-2

 Print Platen 9-3

 Printer 9-2

Color Calibration 5-7

Color differences 1-6

Cover Sensors 1-3

Cutter Assembly 8-32

Cutter Bushing 8-35

Cutter Guide 8-55

Cutter Guide Bracket 8-36

D

Drive Roller 8-86

Drive Roller Encoder Sensor 8-38

E

EEROM Setup 4-16

 Change Font Type 4-18

 Reset EEROM Values 4-20

 Reset Usage Counter 4-19

 Select Model Number 4-16

 Select Serial Number 4-17

Electrical System 10-3

Electronics Module 8-24

Encoder Strip 8-76

Entering

 Error Log Utility 2-5

 Printhead History Utility 3-14

 Service Calibrations 5-3

 Service Tests 4-4

 Service Utilities 4-14

Entering Service Menu at Power Up 1-13

Error Log Utility 2-5

ESD Precautions 8-3

Expiration Message 3-6

F

Factory Advance Calibration 5-11

Fork Idler, Tensioner and Idler Pulley 8-74

Formatter 8-20

Formatter/Accessory Card 1-14
Front Panel 8-9, 10-6
Functional Overview
 Electrical System 10-3
 Front Panel 10-6
 Ink Delivery System 10-7
 Ink Supply Station 10-7
 Power Supply Unit 10-5
 Service Station 10-10
 SKU Overview 10-2
 Tubes Assembly 10-9

G

Gear Assemblies 8-92

I

Ink Cartridge Error Message 3-6
Ink Cartridges 3-2
 Obtaining Information 3-9
 Status Messages 3-12
 Troubleshooting Repetitive Messages
 3-20
 When should they be replaced 3-6
Ink Delivery System 10-7
Ink Supplies
 General Information 3-4
 General Precautions 3-5
 Identifying the Components 3-3
 Ink Cartridges 3-2
 Printheads 3-3
 Summary of Solving Problems 3-23
Ink Supply Station 8-48, 10-7
Ink Supply Station Test 4-6
Ink Supply Tubes 8-60
Installing
 Carriage Assembly 8-83
 Electronics Module 8-26
 Scan-Axis Motor Assembly 8-31
 Service Station/Aerosol Fan 8-54
 Trailing Cable 8-47
Interconnect Cable 8-59

Interconnect PCA 8-50
Installing
 Air Pressurization System 8-20
 Carriage Assembly 8-51
 Electronics Module 8-27
 Platen Assembly 8-63
 Right Hand Cover 8-6
 Trailing Cable 8-40
Interface Specifications 10-17
ISS Assembly 7-14

L

LAN Card 8-21
Left Encoder Holder 8-33
Left End Roll-Feed 8-13
Left Hand Cover 8-5
Level of Printer Usage 9-3
Line Sensor 1-3

M

Media 6-10
Media Deflectors 8-11
Media Jams 1-4
Media Sensor 8-19
Moisture on the Printer 9-2

N

Noisy Carriage Bushing 9-2

O

Out of Ink Message 3-6

P

Paper Advance Test 4-10
Paper-Axis Motor 8-84

-
- Paper-Axis Shutdowns 1-4
 - Parts List
 - Back Platen Assembly 7-12
 - Carriage Assembly 7-34
 - Cutter Assemblies 7-18
 - Drive Roller 7-42
 - Drive Roller Encoder Sensor 7-30
 - Electronics Module 7-14
 - Ink Delivery System 7-20
 - Interconnect Cable 7-38
 - Left Hand Cover 7-6
 - Miscellaneous Items 7-44
 - Paper-Axis Motor 7-40
 - Pinch-Wheel Assemblies 7-26
 - Power Supply 7-16
 - Print Platen Assembly 7-32
 - Printer Support 7-2
 - Right Hand Cover 7-4
 - Rollfeed Module 7-10
 - Scan-Axis Motor 7-28
 - Service Station and Spittoon 7-22
 - Service Station Holder 7-24
 - Top Cover and Deflectors 7-8
 - Vacuum Fan 7-36
 - Pen to Paper Spacing Calibration 5-5
 - Phone Support 4-2
 - Pinch-Arm 8-66
 - Pinch-Arm Lever 8-69
 - Pinch-Arm Mechanism 8-67
 - Pinch-Arm Sensor 8-71
 - Power Supply 8-27
 - Power Supply Unit 10-5
 - Power Switch LED to Troubleshoot 1-10
 - Preventive Maintenance Kit 9-4
 - Prime Tubes 4-23
 - Priming Procedure 1-7
 - Priming Procedure Fails 1-7
 - Print Platen 8-56
 - Print Quality
 - Troubleshooting Checklist 6-2
 - Printer doesn't power ON 1-3
 - Printer Information 4-26
 - Carriage Usage 4-28
 - Cutter Usage 4-28
 - Engine Firmware 4-27
 - Formatter Firmware 4-27
 - Hard Disk Firmware 4-27
 - Ink Usage 4-27
 - Model Number 4-27
 - Paper Axis Usage 4-28
 - Paper Usage 4-27
 - Pinch-Lift Usage 4-28
 - Scan Axis Usage 4-27
 - Serial Number 4-27
 - Service Station Usage 4-28
 - Spittoon Usage 4-28
 - Printhead Alignment 5-5
 - Printhead Error (unknown) Message 3-7
 - Printhead Error Message 3-7
 - Printhead History Utility 3-14
 - Printhead Warning Message 3-8
 - Printheads 3-3
 - Error Codes 3-22
 - Obtaining Information 3-10
 - Repetitive Problems 3-16
 - Replacing too Early 3-18
 - Status Messages 3-13
 - Troubleshooting Repetitive Error Messages 3-21
 - When should they be replaced 3-7
 - Problems
 - Color Accuracy 6-9
 - Color Consistency 6-9
 - Cover Sensors 1-3
 - Line Sensor 1-3
 - Long Term Color Bleeding 6-9
 - Vacuum Fan 1-5
 - Vacuum suction 1-5
- ## R
- Removing
 - Back Platen 8-17
 - Carriage Assembly (including Belt) 8-78
 - Cutter Assembly 8-32
 - Cutter Bushing 8-35
 - Cutter Guide 8-55
 - Cutter Guide Bracket 8-36
 - Drive Roller 8-86
-

- Drive Roller Encoder Sensor 8-38
 - Electronics Module 8-24
 - Encoder Strip 8-76
 - Fork Idler, Tensioner and Idler Pulley 8-74
 - Formatter 8-20
 - Front Panel 8-9
 - Gear Assemblies 8-92
 - Ink Supply Station 8-48
 - Ink Supply Tubes 8-60
 - Interconnect Cable 8-59
 - Interconnect PCA 8-50
 - LAN Card 8-21
 - Left Encoder Holder 8-33
 - Left End Roll-Feed 8-13
 - Left Hand Cover 8-5
 - Media Deflectors 8-11
 - Media Sensor 8-19
 - Paper-Axis Motor 8-84
 - Pinch-Arm 8-66
 - Pinch-Arm Lever 8-69
 - Pinch-Arm Mechanism 8-67
 - Pinch-Arm Sensor 8-71
 - Power Supply 8-27
 - Print Platen 8-56
 - Right End Roll-Feed 8-15
 - Right Hand Cover 8-7
 - Scan-Axis Motor Assembly 8-29
 - Service Station Holder 8-57
 - Service Station/Aerosol Fan 8-52
 - Spittoon 8-23
 - Trailing Cable 8-40
 - Vacuum Fan 8-64
 - Window and Top Cover 8-10
 - Required Tools 8-3
 - Right End Roll-Feed 8-15
 - Right Hand Cover 8-7
- S**
- Safety Precautions 8-2
 - Scan-axis Maintenance 9-4
 - Scan-Axis Motor Assembly 8-29
 - Scheduled Maintenance 9-3
 - Scratching 6-10
 - Screw Types 8-4
 - Service Calibrations 1-2
 - Advance Calibration 5-9
 - Color Calibration 5-7
 - Entering 5-3
 - Factory Advance Calibration 5-11
 - Printhead Alignment 5-5
 - Service ID 4-27
 - Service Station 10-10
 - Service Station Holder 8-57
 - Service Station/Aerosol Fan 8-52
 - Service Tests 1-2
 - Carriage Movement 4-8
 - Entering 4-4
 - Ink Supply Station 4-6
 - Paper Advance Test 4-10
 - Service Utilities
 - Change Cutter 4-24
 - Change Ink Tubes 4-25
 - EEROM Setup 4-16
 - Entering 4-14
 - Prime Tubes 4-23
 - Printer Information 4-26
 - Turn Drive Roller 4-21
 - Unlock Carriage 4-22
 - Smears 6-10
 - Solving
 - Print Quality Problems 1-3
 - Solving Print Quality Problems 1-3
 - Spittoon 8-23
 - System Error Codes
 - 0110 2-7
 - 0111 2-7
 - 0112 2-7
 - 0113 2-8
 - 0210 2-8
 - 0213 2-8
 - 0310 2-9
 - 0411 2-9
 - 0509 Error 2-9
 - 0510 Error 2-9
 - 0510 Warning 2-9
 - 0511 2-10
 - 0811 2-10

1111 2-10
1113 2-10
1211 2-10
2110 2-11
2111 2-11
2210 2-11
4110 2-11
4113 2-12
4210 2-12
4310 2-12
4311 2-12
5610 2-12
5613 2-13
6104 2-13
6105 2-14
6404 2-14
7104 2-15
7106 2-15
7204 2-16
7304 2-16
7904 2-17
8101 2-17
8111 2-17
8510 2-18
8601 2-18
8611 2-18
8613 2-19
8713 2-19
9310 2-19
Continuable 2-2
Explanation 2-2
Non-Continuable 2-2

T

Trailing Cable 8-40
Troubleshooting
 Boot-Up Sequence 1-12
 Color differences 1-6
 Formatter/Accessory Card LEDs 1-14
 Media Jams 1-4
 Paper-Axis Shutdowns 1-4
 Power Switch LED 1-10
 Priming Procedure 1-7

System Error Codes 1-2
Troubleshooting Procedure 6-4
 Considerations for using 6-4
 Flowchart 6-7
 How to use it 6-4
 No Defects Found 6-8
Tubes Assembly 10-9
Turn Drive Roller 4-21

U

Unlock Carriage 4-22

V

Vacuum Fan 8-64
Vertical Line Straightness Problems 5-5

W

Window and Top Cover 8-10

About this Edition

This is the 1st edition of this Service Manual

1st edition, titled

HP DesignJet 500 and 800 Series Printers Service Manual

What's in this Service Manual

This manual contains information necessary to test, calibrate and service:

- HP DesignJet 500 (models C7769B/C7770B)
- HP DesignJet 500PS (models C7769C/C7770C)
- HP DesignJet 800 (models C7779B/C7780B)
- HP DesignJet 800PS (model C7779C/C7780C)

For information about using these printers, refer to the corresponding User and Quick Reference Guides.

The procedures described in this manual are to be performed by HP-qualified Service Personnel only.